



NORTH DAKOTA COOPERATIVE FUR HARVESTER EDUCATION PROGRAM



North Dakota Fur Hunters
and Trappers Association



Preserving our Heritage – Securing our Future

*North Dakota
Cooperative Fur Harvester Education Program*

Student Manual

North Dakota Cooperative Fur Harvester Education Program Student Manual

This education program is the result of many hours of dedication and commitment from many individuals in the wildlife profession, and is truly a cooperative effort between citizens of North Dakota and federal and state agency personnel. The common denominator is an interest and desire that future generations enjoy the same fur hunting and trapping opportunities that exist today. This education program, the program committee, and volunteer instructors are charged with execution of those duties.

Our gratitude extends to the Association of Fish and Wildlife Agencies for providing the blueprint to this manual; the North Dakota Chapter of the Wildlife Society; the U.S. Department of Agriculture – Wildlife Services; and the North Dakota Game and Fish Department for acknowledging the importance of fur hunting and trapping by providing the resources and financial support for the program.

In addition, we express our sincere appreciation to the North Dakota Fur Hunters and Trappers Association and volunteers for their dedication and countless hours committed to this program. It is that volunteer spirit and quality of leadership that will serve to ensure that future generations have the same fur hunting and trapping opportunities we have today.

The North Dakota Cooperative Fur Harvester Education Program Committee

Illustrations and photographs are protected by copyright laws. Information on reproduction rights and privileges is available from the North Dakota Cooperative Fur Harvester Education Program, the North Dakota Fur Hunters and Trappers Association, or the North Dakota Game and Fish Department.

Cover Photo by Craig Bihrlé

THIRD EDITION

Table of Contents

Chapter 1 – Introduction to Trapper Education	1
<i>Content Standard – Students demonstrate an understanding of the purpose of trapping and trapper education in today’s society.</i>	
Chapter 2 – Historical Considerations	10
<i>Content Standard – Students use knowledge of history, public attitudes about wildlife, and the North American Model of Wildlife Conservation to understand regulated trapping as a legitimate activity.</i>	
Chapter 3 – Furbearer Management	19
<i>Content Standard – Students use knowledge of furbearer management principles, practices and issues to explain current management programs in their state.</i>	
Chapter 4 – Trapping Regulations	31
<i>Content Standard – Students demonstrate the ability to understand, support and comply with trapping regulations.</i>	
Chapter 5 – Best Management Practices	36
<i>Content Standard – Students understand Best Management Practices for Trapping were created to address animal welfare, trapping efficiency, selectivity and safety in furbearer management programs.</i>	
Chapter 6 – Traps	40
<i>Content Standard – Students demonstrate the ability to identify types of traps, prepare traps for use, and safely operate traps.</i>	
Chapter 7 – Trapping Equipment	55
<i>Content Standard – Students identify essential and nonessential equipment and clothing used to set traps and run a trap line.</i>	
Chapter 8 – Using Bait, Lures and Urine	61
<i>Content Standard – Students explain responsible use of lures, bait and urine to attract furbearers to sets.</i>	
Chapter 9 – Selective Trapping Techniques	64
<i>Content Standard – Students demonstrate an understanding of trapping principles and techniques that increase selectivity of sets.</i>	
Chapter 10 – Water Sets	70
<i>Content Standard – Students demonstrate an understanding of the procedures for making safe, effective and selective sets in or near water.</i>	
Chapter 11 – Land Sets	80
<i>Content Standard – Students demonstrate an understanding of the procedures for making safe, effective and selective sets on land.</i>	
Chapter 12 – Cable Devices	91
<i>Content Standard – Students demonstrate an understanding of cable devices and responsible techniques for using them.</i>	
Chapter 13 – Trapping Safety	103
<i>Content Standard – Students demonstrate an understanding of potential risks to their personal health, safety and welfare from trapping activities.</i>	
Chapter 14 – Running a Trap Line	115
<i>Content Standard – Students demonstrate an understanding of the knowledge, skills, and attitudes needed to safely and responsibly harvest furbearing animals using Best Management Practices.</i>	
Chapter 15 – Predator Calling	122
<i>Content Standard – Students demonstrate an understanding of predator calling equipment and techniques.</i>	
Chapter 16 – Hound Hunting	132
<i>Content Standard – Students demonstrate an awareness of hunting furbearers with dogs.</i>	
Chapter 17 – Using Furbearers	141
<i>Content Standard – Students demonstrate an understanding of the full value of harvested furbearers.</i>	
Chapter 18 – Handling Fur	152
<i>Content Standard – Students demonstrate an understanding of the knowledge, skills and equipment needed to safely skin animals and prepare pelts for market.</i>	
Chapter 19 – Responsible Trapping	169
<i>Content Standard – Students demonstrate an awareness of their responsibilities to landowners, wildlife, other outdoor users and the public.</i>	
Chapter 20 – Furbearers	178
Chapter 21 – Glossary	196
Chapter 22 – References	201
Appendix A – Trap Selectivity Matrix	204
Appendix B – Authentic Assessments	205
Appendix C – North Dakota Game and Fish Department Furbearer Survey	208



Content Standard – Students demonstrate an understanding of the purpose of trapping and trapper education in today's society.

Introduction

Trapping is part of our North American heritage. First-time trappers in many states and Canadian provinces must complete a trapper education program covering skills, regulations and the role of trapping in wildlife management. Trapper education programs teach basic techniques with a strong focus on the responsible treatment of animals, legal methods, safety, selectivity, and ethical trapper behavior.

This trapper education program was developed by the North Dakota Game and Fish Department, volunteer representatives from the fur hunting and trapping community in North Dakota and the Association of Fish and Wildlife Agencies. The Association is comprised of and represents professionals from fish and wildlife agencies of states, provinces and federal governments of the United States and Canada. The program was developed to:

- Protect the health, safety, and welfare of people, wildlife and domestic animals.
- Support wildlife conservation programs that sustain species and ecosystems for the benefit of future generations.
- Increase the benefits society currently receives from regulated trapping activities.

Recognize that the decision to become a trapper represents a serious commitment of time and dedication to responsible behavior

Trapping is a highly regulated activity because the public is concerned about wildlife conservation and the welfare of wild animals. Regulations are designed to help manage furbearing animals using safe and selective equipment and techniques.

Trapping takes a lot of time and dedication. Trappers spend time studying wildlife, scouting, preparing traps, working with landowners, setting traps, running trap lines and preparing pelts. When trapping season begins, trappers must check their traps routinely until they are removed.

Society – trappers, and nontrappers alike – will not accept illegal or unethical behavior. This course will teach you the basics. You must be willing to spend the time and effort to trap responsibly.

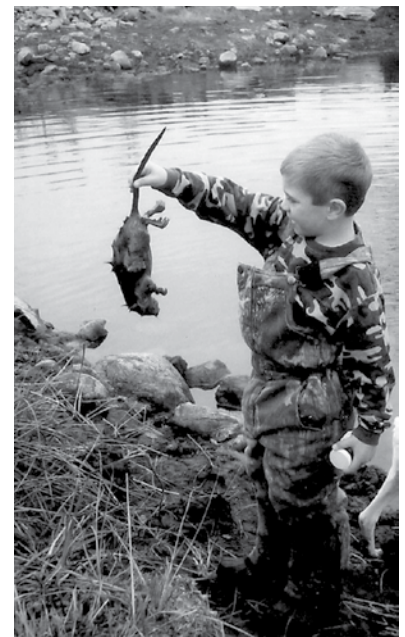

First muskrat. Chris Tischaefner

Trapping benefits society.

Trapping is highly regulated.

Trapping is a highly engaging, year-round activity.



Marty Beard

Fur handling is rewarding work for all ages.

Illegal or unethical behavior is not acceptable. Show respect for wildlife, people and property.

Farmers who have crop damage will often give you permission to trap.



Silvertip Productions

Trapping is a way of life for many people.

List five positive or negative values of furbearers including ecological, biological, cultural, aesthetic and economic values

Fur products and trapping are still culturally and economically important. Furbearers are used and managed as valuable natural resources.

Values associated with furbearers:

- Economic – Positive values include furs, meat and by-products such as perfume and fishing and trapping lures. Examples of negative values include crop depredation, property damage and flooded roads.
- Ecological – Furbearers have positive value as predators and prey in functioning ecosystems. Excessive numbers of furbearers can have negative values if they harm habitats or prey on endangered animals.
- Cultural – Trapping is valued by many people as part of their cultural heritage. Trapping involves outdoor skills, knowledge and respect for wildlife, and family activities. Some people look to nature or the land to provide vegetables, firewood, venison and furbearers. Trapping provides these people with needed food and clothing.
- Biological – Furbearers have positive values that help us understand human health and the effects of environmental pollutants. Negative biological values include human exposure to disease and parasites.
- Aesthetic – Furbearers have many positive aesthetic values for fur and wildlife watching.

List a minimum of four benefits regulated trapping provides to society

Responsible trappers provide these benefits to society:

- Disease Control – Reducing populations helps limit the spread of diseases among animals and people.
- Habitat Protection – When furbearers overpopulate they can destroy habitat. For example, the harvest of nutria in Louisiana helps protect 3.6 million acres of coastal wetlands.
- Endangered Species Protection – Foothold traps help protect many rare and endangered species from predators. Examples of animals that have benefited include the desert tortoise, sea turtles, whooping cranes, black-footed ferrets and piping plovers.
- Property Protection – Farmers and other landowners benefit when trappers remove furbearers that threaten property and crops.
- Wildlife Restoration – Trappers use foothold traps to humanely capture species such as river otters in states where they are plentiful so they can be released in other states to reestablish populations.
- Wildlife Research – Foothold traps and cable devices are the only effective means for catching elusive species such as wolves, coyotes and foxes. Wildlife biologists depend on traps and trappers to help study many species of wildlife.



- Helping Maintain Balance – Trappers take the place of large predators, where these animals no longer occur or are rare, in controlling middle-size furbearers, thus helping maintain balance in the ecosystem.

Know that trapping is an individual privilege, not an individual right.

In most states, trapping is an individual privilege available to all citizens who choose to follow regulations and behave responsibly. Trappers who violate laws can lose their privilege to trap. If trappers as a group do not behave responsibly, citizens could decide to stop all trapping.

Some states have made it a collective right to hunt, fish, and trap. This protects the activity of trapping for future generations. It does not protect trapping privileges for people who violate trapping regulations. Judges can, and do, suspend trapping privileges for serious violations.

Identify a minimum of two state or national trappers associations that provide materials and continuing education for trappers

Trappers have formed state and national organizations to help address issues related to trapping and furbearer management. Two national groups include the National Trappers Association and the Fur Takers of America.

The National Trappers Association has the following purpose statement:

- To promote sound conservation, legislation, and administrative procedures.
- To save and faithfully defend from waste the natural resources of the United States.
- To promote sound environmental education programs.
- To promote a continued annual fur harvest using the best tools presently available for that purpose.

The Fur Takers of America has the following purpose:

- To promote interest in and accumulate and disseminate knowledge concerning the trapping of furbearing animals among persons interested therein.

You can find out more about the NTA and FTA at their websites.

- <http://www.nationaltrappers.com/>
- <http://www.furtakersofamerica.com/>



Whooping crane.

FWS

Wetland habitats are home to hundreds of species of wildlife.

When voters restricted trapping in Massachusetts in 1996 landowner beaver complaints doubled.

A U.S. Fish and Wildlife Service survey revealed 487 wildlife management programs that involved trapping on 281 national wildlife refuges.



FWS



Organized trappers, hunters, and anglers have supported fish and wildlife conservation programs for more than 100 years.

Membership in state and national trapping organizations will help you become a more successful and responsible trapper.

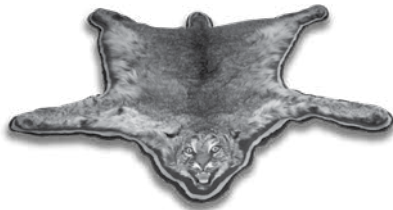

Bobcat pelt rug.

Marty Beard

Online bulletin boards for trappers are a good way to learn new techniques and solve problems. Post a question, and get answers from friendly, experienced trappers.

The websites also link to state trapping associations, online bulletin boards and other helpful organizations.

There are many benefits to membership in trapping organizations. You will learn new techniques to become more successful, be invited to meetings and other activities, gain a greater understanding of wildlife management, and learn about issues affecting trapping.

Know the legal types of traps that may be used in your state.

States consider animal welfare, efficiency, selectivity, and safety when they select legal traps. Each state regulates the types of traps that are legal. Legal traps and sets are either kill-type or live-restraining devices. The tools used in both of these categories are explained in later chapters.

Name the species of furbearers that inhabit your state

The following species are known as furbearers in North America. Some of these species will not be present in your state. Even if a species is present there may be no open trapping season for it in your state.

Place a check in the box on the following chart to indicate if a species is present, and if there is an open trapping or hunting season for it in your state. Use the North Dakota hunting and trapping regulations brochure to find this information.



Raccoon.



Coyote.

FWS



Beaver.

FWS

The ability to participate in activities like hunting and trapping is a privilege, not an individual right.

Species	Present	Trapping or Hunting Season
Coyote		
Red fox		
Gray fox		
Gray wolf		
Swift/kit fox		
Arctic fox		
Beaver		
Muskrat		
Nutria		
Bobcat		
Canada lynx		
Mink		
River otter		
Fisher		
Marten		
Weasels		
Striped skunk		
Badger		
Opossum		
Raccoon		
Ringtail - Bassarisk		
Wolverine		
Other:		

Trapping technology and techniques have shown continuous improvement for nearly 200 years.

Raccoons, beavers, and coyotes are widely distributed in the United States.

The gray fox is common in many parts of the country, and occasionally found in wooded areas of eastern North Dakota.

Even though a furbearer is present within your state, it may be restricted to specific habitats within a certain range.

Responsible trappers care about wildlife conservation and animal welfare.

Nutria were introduced from South America. They are found in the Gulf Coast states, parts of the East Coast, Washington and Oregon.



Nutria.

FWS



Gray fox.

FWS

Know that the Trapper Education Course is based on Best Management Practices developed by wildlife biologists, trappers and researchers.

State fish and wildlife agencies, trapping organizations, veterinarians and university researchers help develop Best Management Practices for regulated trapping in the United States.

Trapping BMPs are documents that provide information to help trappers practice safe, humane, and efficient capture techniques. BMPs describe different types of traps, how they work, how traps should be set, and what training may be needed for people who use BMP-recommended traps.

Five criteria are considered when developing BMPs:

- **Animal welfare** – Researchers tested live restraining traps for injuries to furbearers using two methods. One system evaluated specific injuries, and the other grouped the injuries into categories from mild to severe. BMP-approved traps must have a low rate of injuries to the furbearing animals being studied. Recommended traps resulted in moderate, low, or no injury to at least 70 percent of the animals trapped.
- **Efficiency** – Traps meeting BMP criteria must be able to capture and hold at least 60 percent of the furbearers that spring the trap.
- **Selectivity** – Traps must be set and used in a fashion that limits the risk of capturing nonfurbearing species while increasing the chances of capturing the desired furbearer.
- **Practicality** – Each recommended live restraining trap was evaluated by experienced trappers and wildlife biologists for practicality. Criteria used to measure practicality included cost, ease of use, ease of transport, storage, weight and size, reliability, versatility, and the expected life span of the trap.
- **Safety** – Each recommended live restraining trap was evaluated for safety to the user and other people who might come into contact with the trap.



North Dakota Game and Fish Department Policy on Trapping

The North Dakota Game and Fish Department recognizes that regulated fur hunting and trapping is a versatile, safe, efficient and ecologically sound means of capturing individual animals without impairing the survival of furbearer populations or damaging the environment. Trapping and hunting provide an outdoor lifestyle for many North Dakota citizens through the use of an abundant natural resource as well as an effective means of harvesting, managing and studying furbearers; controlling damage caused by furbearers; and, at times, reducing the spread of harmful diseases. The Department also recognizes that trapping does concern some people who oppose trapping, the use of specific trapping devices, or consumptive use of animals.

The Department supports regulated trapping and efforts to address societal concerns through appropriate education, research, enforcement and regulatory programs. Such programs shall be designed to increase awareness and acceptance of trapping by seeking to enhance animal welfare while maintaining wildlife management capabilities and other benefits associated with this activity.

North Dakota Game and Fish Department
100 North Bismarck Expressway
Bismarck, North Dakota 58501
Phone: (701) 328-6300
(web: gf.nd.gov) (email: ndgf@nd.gov)

Confidential information concerning violations can be reported by calling 701-328-9921

State wildlife agencies prohibit the taking of any species if it would negatively affect the population.



River otter.

FWS



Opening day.

Silvertip Productions

Chapter 1 – Introduction to Trapper Education

Content Standard – Students demonstrate an understanding of the purpose of trapping and trapper education in today’s society.

Recognize that the decision to become a trapper represents a serious commitment of time and dedication to responsible behavior.

- When trapping season starts, trappers must check their traps _____ until all are removed.
- List five positive or negative values of furbearers including ecological, biological, cultural, aesthetic and economic values.
 1. _____
 2. _____
 3. _____
 4. _____
 5. _____
- List two products that come from furbearers.
 1. _____
 2. _____
- List two problems caused by furbearers.
 1. _____
 2. _____
- List two positive values of furbearers in functioning ecosystems.
 1. _____
 2. _____
- List two problems that may result when furbearers overpopulate.
 1. _____
 2. _____
- Trapping is valued by many people as part of their _____ heritage. Trapping provides people with food and _____.
- Furbearers help us understand _____ health.
- Furbearers may expose humans to disease and _____.
- Furbearers have positive values for _____ and wildlife watching.

List a minimum of four benefits that regulated trapping provides to society.

1. _____
 2. _____
 3. _____
 4. _____
- List ways that society benefits from trappers.
 1. Disease _____
 2. _____
 3. _____

Choose correctly that trapping is an individual privilege, not an individual right.

- Trappers who violate laws can lose their _____ to trap.

Identify a minimum of two state or national trappers associations that provide materials and continuing education for trappers.

1. _____
 2. _____
- Name two trapping associations you can join.
 1. _____
 2. _____

Know the legal types of traps that may be used in your state.

- Put a check mark beside the traps that are legal to use in your state.
 1. ___ Foothold traps
 2. ___ Body-gripping traps
 3. ___ Cable devices
 4. ___ Cage traps
 5. ___ Deadfalls

Name the species of furbearers that inhabit your state.

- Using your state trapping regulations, name five common furbearers that are legal to trap in your state.
 1. _____
 2. _____
 3. _____
 4. _____
 5. _____

Know that the Trapper Education Course is based on Best Management Practices developed by wildlife biologists, trappers and researchers.

- Name five factors or components considered during the development of Best Management Practices.
 1. Animal welfare
 2. _____
 3. _____
 4. _____
 5. _____



Alaskan trapper cabin. FWS

Fun to know

Beaver felt hats were prized possessions among European men during the 1700s and early 1800s. They were expensive to make. Beavers were captured in North America and shipped a long distance to reach Europe. The manufacturing process was complex.



Kit fox. FWS

Content Standard – Students use knowledge of history, public attitudes about wildlife, and the North American Model of Wildlife Conservation to understand regulated trapping as a legitimate activity.

Students become aware of the fur trade’s role in the exploration and settlement of North America

North America’s fur trade began during the 1500s when Europeans explored the eastern coast. Native Americans gave the Europeans furs, deer hides and meat in exchange for iron tools, wool blankets, colorful cloth and guns. Samuel De Champlain, a French explorer, established the first North American fur trading post in Quebec, Canada, in 1608.

The fur trade became North America’s primary business, and it was dominated by the French until 1760. Numerous cities such as New York, Chicago and St. Louis started as trading posts.

Many wars and battles were fought over the fur trade. During the 1600s, the Iroquois Nation frequently battled other native tribes in Canada and the Ohio Valley to gain control over land where furbearers lived. This period of time is known today as the Beaver Wars.

The abundance of furs in what is now North Dakota was the key to opening the state. Almost without exception, every venture into North Dakota during the first 125 years of its development was influenced by trapping and fur trading interests. The first white man in North Dakota (Verendrye in 1738) came here on an exploratory visit to the Mandan Indians. His trip was financed by a fur company.

European nations also struggled for control of land and native trade. The Pilgrims at Plymouth, MA, issued licenses to regulate those who were permitted to trade furs with native people. The British gained control of the fur trade in 1760 after winning the French and Indian War.

One of the objectives of the Lewis and Clark expedition in 1804-1806 was to gather information on the abundance and distribution of furbearers. Many forts and fur trading posts were established by various fur companies to accommodate the needs of the trappers and to compete in the business of buying furs from the trappers and Native Americans. Fortunes were made



and lost in the business of buying and trading furs. In 1816, the United States Congress took control and made it illegal for foreigners to trade in this country.

The fur trade declined over time, reaching a low about 1850. Habitat destruction and unregulated killing made furbearers scarce. Europeans were favoring silk over beaver felt, and Native American fur suppliers had declined due to disease, warfare, and displacement from their homelands.

During several centuries of fur trading, there was no effort to conserve wildlife or protect habitat. Everyone competed for the same wildlife resource. Beavers and otters were eliminated from much of the country. The government did not regulate seasons or methods that could be used to take wildlife. Furbearers of all kinds were shot, speared, snared, or killed using deadfalls. Ponds sometimes were drained so all the beavers could be captured.

Steel traps did not play a major role in the development of the fur trade or the widespread declines of beavers, otters, and other furbearers. Steel traps were not mass produced or widely available until after 1823.

Although the beaver was the most sought after and most valued animal, other species also were taken. Other North Dakota fur species which were of value included wolves, fishers, coyotes, black bears, American martens, river otters, raccoons, mink, swift foxes, lynx, bobcats and muskrats.

Widespread habitat destruction played a key role in changes in animal populations. By the late 1800s millions of acres of wetlands were drained, forests were cleared for farms, and prairies were plowed under. Streams and rivers ran heavy with silt, sewage, and industrial waste. In the East, nearly all species of fish and wildlife were in decline.

Changes in the abundance and harvests of fur species have occurred throughout the history of the fur trade and undoubtedly will continue in the future. Change occurs from fluctuations in animal populations, demand, value, continued habitat loss and other economic factors. Unfortunately, very little information is available regarding fur harvests and returns received during much of North Dakota's fur history. However, since 1937, complete records on harvested furbearers have been kept by the North Dakota Game and Fish Department.

An examination of the changes occurring in the fur harvests since 1937 show some of the many changes which affect the fur industry.



Silvertip Productions

Two kinds of beaver fur were used to make felt hats. At first, "coat beavers" were preferred. These were furs that had been worn by Native Americans until the guard hairs wore off.

"Parchment beavers" were prime pelts, but for a long time they had to be shipped to Russia for processing to remove the guard hairs. Eventually French and English hat makers discovered the Russian secrets and began to use parchment beaver for all their felt hats. The final blow to the early fur trade came when silk hats gained popularity in Europe.

Beaver felt commonly is used to make high-quality cowboy hats.



FWS

Grand Squirrel Hunt – Franklin Co., Ohio 1880 Newspaper Story

“The hunt was conducted agreeably to the instructions in our last paper. On counting the scalps it appeared that 19,660 scalps were produced. It is impossible to say what numbers in all were killed, as a great many of the hunters did not come in. We think we can safely challenge any other county in the State to kill squirrels with us.”

Market “Hunters”

Before wildlife was protected by seasons and bag limits, market “hunters” killed millions of animals a year to supply food to restaurants and grocery stores. Market “hunters” had a strict “utilitarian” attitude toward wildlife. They were not “hunters” according to today’s meaning of the word.

Species which were of major importance during one period had little value during the next. For example, from 1937 through 1958, the mink was the most valuable furbearer in North Dakota. Mink pelts sold during this period made up 34 percent of the total harvest fur value. The white-tailed jackrabbit was the second most valuable furbearer and muskrats were third.

Two main factors influence the value of a fur species: 1) the abundance of the animal; and 2) the monetary return received for the animal. Both factors are variable and change from year to year. The harvest of some species such as skunks, foxes, badgers and coyotes tend to follow the return received for the animal. If returns are high, the harvests are above average. The harvests of other species such as mink, muskrats, weasels and beavers are quite consistent even though the return may vary. As a general rule, the value of any year’s harvest will be a product of the number of trappers, the demand for a certain species, and the abundance of the species.

Aside from any monetary return, trapping and hunting is important in North Dakota. Many people participate in these activities for a variety of reasons. Some reasons include learning about the characteristics and habits of the animals themselves, outdoor physical activity, the challenges associated with fair chase, a respect and love for nature and wildlife, protecting personal property, and maintaining a connection with the land. Trapping, predator hunting and hound hunting remain an important activity and lifestyle for many people in North Dakota.

Students recognize that fish and wildlife resources are publicly owned, and managed according to society’s laws, values, and attitudes

In North America, wildlife is a public resource owned by no individual or corporation. State and federal wildlife agencies manage wildlife for the benefit of all people. Public values and attitudes about wildlife determine how it can be used. Since the first European settlement, people’s attitudes about wildlife have changed.

People sometimes have conflicting attitudes about the way wildlife should be used or managed. The most serious conflicts are among people who have different views about killing wildlife. However, even people who hold similar views may disagree on how animals such as furbearers should be managed.

Attitudes and values

The values people place on wildlife underlie their attitudes about when and how animals may be used. People who use wildlife for subsistence may revere animals even though they harvest wildlife for food and clothing. People who misuse or try to exterminate wildlife do not value animals at all until they are dead.



Conservationists place the highest values on preserving habitats, ecosystems, and sustainable wildlife populations. Conservationists accept regulated harvests of surplus animals as appropriate.

Strict protectionists value individual animals. They tend to oppose hunting and trapping out of concern for individual animals. Some protectionists have a mistaken belief that regulated hunting and trapping will threaten the entire population.

Animal rights activists believe all animals have the same rights as humans. They oppose any human use of animals and may value an animal's life as much as a human life.

Subsistence attitude

Prior to European influence, wildlife was a source of food, clothing and tools for Native Americans. They had few crops to grow, and no livestock. The lives of plants and wild animals were spiritually and culturally connected to the lives of native peoples. Later, pioneers such as Daniel Boone and Simon Kenton depended on wildlife as they opened up new territory for settlement. Today, only a few people totally depend on wildlife for subsistence.

Utilitarian attitude

European settlers and Native Americans alike viewed wildlife as a common resource. No one owned wildlife until they killed it. Some people made their living by killing animals for fur, meat or feathers. At the time, there were no government agencies to manage and protect wildlife.

Extermination attitude

When people started farming in the wilderness, wildlife became a nuisance. Bears, wolves and mountain lions were a threat to people or livestock. Deer, raccoons and squirrels damaged crops. Farmers shot wildlife, or paid others to do it. Government agencies paid bounties on many animals.

During the 1800s former military officers sometimes organized "armies" to conduct "wars of extermination" on wild animals. Communities held events to see who could kill the most wildlife on a given day or weekend. Widespread events could result in tens of thousands of animals being killed in a single day.



FWS

Sport Hunters

The term "sport hunter" arose in the United States during the mid-1800s to distinguish those who practiced "fair chase" hunting techniques from commercial "market hunters." Sport hunters placed limits on themselves and their hunting methods in order to test their skills and give animals a reasonable opportunity to escape. The code of the sportsman arose to define proper conduct for hunters.



Bobcat.

FWS

Great Hinckley Hunt, 1818

On December 24, 1818, 600 armed men encircled Hinckley Township in northeastern Ohio. They marched toward a central point and shot 300 deer, 21 bears, 17 wolves, plus hundreds of turkey, fox, and raccoons. This was an effort to exterminate all the wildlife.

Conservation attitude

By the mid-1800s many people no longer depended on wildlife for survival. Some began to enjoy hunting, fishing and camping as leisure activities.

Habitat destruction, market hunting and extermination efforts were reducing animal populations. As wildlife became scarce, conservation became a concern for hunters. Conservationists wanted to save critical habitats and remaining wildlife populations. There was no scientific knowledge about wildlife management. It took decades to create natural resource agencies and funding sources. Leaders such as President Theodore Roosevelt, a hunter, created public support for wildlife and a conservation ethic.

Today, wildlife conservation programs are based on sustainable use. Individual animals may be used in accordance with laws, while habitats and animal populations are preserved. Many people, including hunters and trappers, are conservationists who care about wildlife while recognizing that regulated use is beneficial to society and the resource.

Preservation attitude

Many people value wildlife but they fail to see the positive connection between hunting and trapping, and sustainable populations. Preservationists may oppose hunting and trapping in the belief it endangers animals. However, many preservationists are open-minded, and willing to examine facts about wildlife management.

Animal rights attitude

A small but highly vocal group of Americans believe in animal rights. The primary concern of animal rights advocates is the moral obligation of people. They believe animals have the same rights as humans and therefore oppose any human use of animals including hunting, trapping, farming practices, research on animals, rodeos, circuses, horse races, and other animal-related activities. Some animal rights proponents even oppose owning animals as pets.

Apathetic attitude

A high percentage of the American population is growing up with little connection to the land. Few people think about wildlife on a daily basis, and most have no personal experience that would help shape their attitude. If they encounter wildlife doing damage to their property, they may want it exterminated or removed. If someone shows them pictures of animals in traps and claims it is cruel, they may oppose trapping or vote to make it illegal. An apathetic person's attitude can be easily changed, but they may not spend much time considering the issues.



Animal welfare and animal rights

Most Americans, including those who trap, care about animal welfare. A small number of people hold animal rights beliefs. A person concerned with animal welfare wants to minimize pain and suffering when animals are trapped, or used any other way. A person who believes in animal rights believes animals have a right not to be trapped at all.

Most trappers are concerned with animal welfare. Those who are not are unlikely to be accepted by other trappers.

Wildlife agencies are concerned about sustainable long-term populations and individual animal welfare. Many trapping regulations are enacted to improve animal welfare. Agencies regulate types of traps that may be used, where they may be set, seasons, and how often traps must be checked. Trapper education programs play a role in animal welfare, too.

One of the most important efforts to improve animal welfare is known as the Best Management Practices project. The Association of Fish and Wildlife Agencies has spent years working with wildlife agencies, trappers, veterinarians, universities, and other groups to develop Best Management Practices. This project is ongoing, and provides information used in this Trapper Education Manual.

Students identify key components of the North American Model of Wildlife Conservation

The United States and Canada have the most successful system of wildlife management the world has ever known. Conservationists, especially hunters and trappers, supported the development of The North American Model of Wildlife Conservation. This model is defined by seven principles:

1. Wildlife as a public trust resource

Legally, wildlife is a public resource, held in trust by the government, and managed by fish and wildlife agencies. State wildlife agencies are responsible for most wildlife management and regulation. The U.S. Fish and Wildlife Service has authority over migratory birds and federally endangered species. The Service works cooperatively with the states and other nations.

2. Elimination of markets for wildlife

The elimination of market hunting of most wildlife for meat, feathers or other uses was critical in halting what would have been a “tragedy of the commons.” Using regulated



Red fox pup.

Craig Bihrlé
NDGFD

Some people oppose any use of animals, including human consumption of meat, fish, eggs and milk.

Tragedy of the Commons

The “Tragedy of the Commons” relates to common resources that are available to all. In this situation, the greediest will gain the most, for a time. Restrictions on use of common resources are necessary to prevent overuse by individuals that could result in the loss of these resources to society.



Muskrat.

FWS

trapping, furbearer populations sustain annual harvests and provide significant benefits to society.

3. Allocation of wildlife by law

Public privileges to use wildlife and have a say in its management are guaranteed by law. Hunting and trapping privileges are not restricted to wealthy landowners or granted as special considerations. Individuals can lose their privileges if they violate laws pertaining to the legal harvest of wildlife.

4. Wildlife may be killed only for a legitimate purpose

Killing wildlife for frivolous reasons is prohibited by law. If society is going to sanction the killing of wildlife it must be for a legitimate purpose such as using the animal or its parts for food, clothing, medicine, self-defense, or property protection.

5. Wildlife is considered an international resource

The Migratory Bird Treaty of 1916 between the United States and Canada was the world's first significant international treaty for the management of wildlife. Today, waterfowl, songbirds, and other migratory wildlife benefit from international management and regulation.

6. Science is the proper tool for discharge of wildlife policy

Science has been the primary basis for wildlife restoration and management, and the formation of the wildlife profession. North Americans used wildlife science as a basis for managing wildlife decades ahead of everyone else in the world.

7. Democracy of hunting and trapping

In North America, everyone has the opportunity to participate in regulated hunting and trapping. President Theodore Roosevelt wrote about the societal gains to be made by keeping land available for hunting for all people. This is very different from a model that existed for centuries in Europe, where wealthy people owned wildlife and the land, and only the wealthy could fish and hunt. In North America, wildlife is owned by the public, and responsible citizens have equal opportunities to participate in regulated hunting or trapping.

Hunters and trappers provide the funding for wildlife management programs and the purchase of critical habitats. When they join together with a common purpose, hunters and trappers are a political force speaking out in favor of wildlife conservation.



Thanks to conservation-minded hunters and trappers, species such as elk, deer, geese, wild turkeys, wood ducks, beavers, bald eagles, and river otters are more numerous today than they were in 1900. Hunters, trappers and other conservationists were the first people to place a value on living wildlife. As a result, wildlife now is managed as a public resource to be conserved for the benefit of all.

Students use their knowledge of history, public attitudes about wildlife, and the North American Model of Wildlife Conservation to participate in discussions about regulated trapping and the role of trappers in today's society

Think about each of the people in the following scenarios and the attitudes they may have about furbearers and trapping. What would you do in this situation? If you could talk to the people, what would you say? What might change their feelings? If everyone in your community had the same attitudes about wildlife, what might happen as a result?

Scenario 1 – You stop at a roadside stand where a farmer sells fruits and vegetables. You overhear a customer say “Why is your sweet corn so expensive this year?” The farmer says “Raccoons have eaten nearly half my corn. I never saw so much damage.”

Scenario 2 – Your family has trapped on several properties in your neighborhood for many years. One property with two large ponds was recently sold. A month before trapping season opens you stop by to introduce yourself. A young child waves at you as you pull in the drive. As you get out of the car you notice a bumper sticker on the car in front of you. It says “Real Men Don't Eat Meat.” The front door opens and a young man steps out to check on the child.

Scenario 3 – You take your dog to the vet for annual shots. While you are waiting a woman rushes in crying and holding a badly injured cat. She tells the receptionist her cat is dying after being attacked by a coyote.

Scenario 4 – You are sitting in a restaurant having lunch. You overhear a conversation at the table next to you. It sounds like the three men sitting there are poaching deer and selling the meat, but you aren't sure. Sometimes their talk sounds like it is in code. When you leave the restaurant there is a truck parked next to you. You see a spotlight on the seat. As you back out you notice blood and deer hair on the bumper.



Coyote.

Craig Bihrie
NDGFD



Bobcat.

FWS

Furbearers are not considered to be migratory. State fish and wildlife agencies are responsible for managing furbearers.

Chapter 2 – Historical Considerations

Content Standard – Students use knowledge of history, public attitudes about wildlife, and the North American Model of Wildlife Conservation to understand regulated trapping as a legitimate activity.

Students become aware of the fur trade’s role in the exploration and settlement of North America.

- Name a city in North America that started as a fur trading post.

Students recognize that fish and wildlife resources are publicly owned, and managed according to society’s laws, values and attitudes.

- State and federal wildlife agencies are entrusted with the _____ of wildlife for the benefit of all people.
- _____ place the highest values on preserving habitats, ecosystems, and sustainable populations of wildlife.

Students identify key components of the North American Model of Wildlife Conservation.

- _____ has been the primary basis for wildlife restoration and management.

Students use their knowledge of history, public attitudes about wildlife, and the North American Model of Wildlife Conservation to participate in discussions about regulated trapping and the role of trappers in today’s society.

- Pick one of the scenarios at the end of Chapter 2. Describe what you could say or do if you were there.

Chapter 3

Furbearer Management



Content Standard – Students use knowledge of furbearer management principles, practices and issues to explain current management programs in their state.

Introduction

Wildlife management is taught as a science. Wildlife biologists are professionals. Biologists strive to apply the basic principles of ecology to maintain and manage wildlife. Many biologists are as highly trained as physicians, lawyers, or college professors.

Some wildlife biologists specialize in the management of furbearers and their habitats. Furbearer biologists monitor animal populations, habitat and diseases that may affect furbearers or cause human health problems. They develop management goals and create plans to meet those goals.

Furbearer biologists set regulations to protect or restore threatened and endangered species, allow for the harvest of surplus animals, or reduce overabundant furbearer populations. They also work to educate landowners and the general public. Without education, it is difficult to have public support for management programs.

Few people truly understand wildlife management. Along with biologists, experienced trappers are among the people most knowledgeable about wildlife. This is because trappers must study wildlife and habitats to be successful.

As people learn more about wildlife, they usually care about it more. When caring leads to actions that conserve wildlife for future generations, the person has become a conservationist. This chapter will introduce you to the principles of furbearer management. Through further study and experience, you can develop the knowledge, skills, and attitudes to become a true conservationist.

Identify the government agency with the authority to manage furbearer resources and regulate trapping in your state

State wildlife agencies have the authority and responsibility to manage furbearer resources and regulate trapping. The North Dakota Game and Fish Department manages North Dakota's furbearer resources for the benefit of the citizens of the state. The Department recognizes that

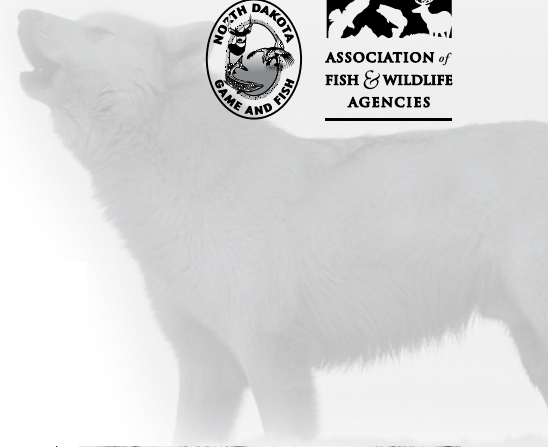

Biologist with wolf.

FWS

Responsible trappers learn about wildlife and take action to conserve it for future generations.



Volunteer works on nest box at U.S. Fish and Wildlife Service refuge.

FWS



Trees, like wildlife, are renewable. Silvertip Productions

State agencies are charged with the responsibility to manage wildlife on behalf of the public.



Oil is a nonrenewable resource. FWS



Beaver lodge. FWS

furbearers have a variety of ecological, cultural, economical and aesthetic values, and that these values can be positive or negative. Also, since values are determined by people, not nature, the same animal can have a wide range of values depending on the time, the place, and who is being affected by it.

In order to responsibly manage furbearers, the Department monitors furbearer populations and harvests, sets regulations, maintains habitats, and enforces laws related to furbearers.

Seasons

Trapping and hunting seasons are based on furbearer populations. Seasons are not permitted if they are deemed detrimental to the survival of the species. Once biological requirements are met, further decisions are based primarily on the concerns of people who use, value, or are affected by the resource. Opportunity, fur primeness, damage problems, land-owner concerns, nonharvest values, disease and other factors all enter into these decisions and opportunities for public input are provided.

Surveys

Harvest and fur value surveys are conducted for all harvestable furbearer species in North Dakota. For species that are more sensitive, harvest figures are determined through pelt registration. For those species, carcasses also are collected from trappers and hunters, and information on location, sex ratios, age and productivity are used to assess the health of the population. Appendix C contains an example of a furbearer survey used by North Dakota Game and Fish Department.

Habitat

Although furbearers often are not the highest priority in many habitat management programs, the fact remains that furbearing animals are primary beneficiaries of many of these practices. This is particularly true of wetland areas, which are prime habitat for muskrats, mink, beavers, raccoons, foxes, and other furbearers. In fact, furbearers often do so well in these areas that conflicts develop with management for other species such as waterfowl. Forest management practices also influence furbearer populations, with some species favoring early successional stages of vegetation, and others favoring later stages.

Enforcement

Game wardens in North Dakota enforce the laws and regulations relating to furbearers statewide. Of course, they have many more duties in addition to furbearer regulations, but they always are interested in, and concerned about situations where violations are occurring.



It is important, however, for trappers and hunters to police their own ranks and to help enforcement officers by reporting violations. People who take furbearers illegally are stealing from honest citizens of the state.

Conservation and Trap Line Management

Furbearer regulations are established for the entire state, or for large regions of the state, depending on the species. Conditions vary within such large areas, therefore, it is up to trappers to practice conservation on their own trap line, and capture only a portion of the surplus. This sounds simple, but actually is quite complicated because in many areas a number of trappers and hunters are competing for the same resource. Fortunately, trapping and hunting tend to be self limiting for many species. The time and effort required to take these animals exceeds the benefit long before they are reduced to critically low levels. For other species which are not so resilient, regulations have to be correspondingly more restrictive.

In areas where trappers have exclusive or near exclusive trapping privileges, individual trap line management is much more feasible. In these areas the trapper can manage not only the harvest, but in many cases the habitat as well. By doing so, the trapper can be assured of having a relatively high sustained harvest year after year.

Regulated fur hunting and trapping provides many benefits for society. For example, they help keep wildlife populations in balance with the environment or at acceptable levels, reduce property damage, support broader conservation programs and obtain many products for human use. While all of these are good reasons for people to support regulated fur hunting and trapping, the future of these practices also depends on their perceptions of fur hunters and trappers and their actions afield. You can do your part to ensure the future of fur hunting and trapping in North Dakota by:

1. Knowing and obeying fur hunting and trapping laws.
2. Assisting in enforcement of fur hunting and trapping laws by reporting violations.
3. Respecting landowners' property and obtaining written permission as required by law.
4. Considering animal welfare in your choice of capture, release and killing methods.
5. Avoiding waste by caring for the animal and the fur properly, and marketing other useful products.
6. Checking capture devices as recommended by law.
7. Disposing of carcasses properly.



Biologist tracking wildlife.

FWS



Millions of Americans hunt and trap.

Silvertip Productions



Habitat destruction leads to long term declines in wildlife populations.

Extirpated means that a species no longer exists in a range where it once lived. It does not mean that a species is extinct.

Major factors that affect wildlife populations

- *Changes in habitat.*
- *Carrying capacity.*
- *Limiting factors such as food, weather and predation.*

Extinction means a species is no longer found anywhere. Passenger pigeons, for example, are extinct.

Wildlife agencies and supporters have restored many species that were once extirpated from entire states. River otters, fishers, and beavers are furbearers that were extirpated from many states and later restored.

8. Supporting local, state, and national fur hunting and trapping organizations.
9. Assisting the North Dakota Cooperative Fur Harvester Education Program by becoming a certified instructor.
10. Promoting fur hunting and trapping by communicating its benefits, especially among nontrappers.
11. Avoiding nontarget catches.
12. Helping landowners reduce property damage caused by furbearers.
13. Reporting the presence of diseased animals and rare, endangered or threatened species to the proper authorities.
14. Respecting others who participate in outdoor activities.
15. Keeping up-to-date on improvements in fur hunting and trapping equipment and methods.

Fur hunting and trapping is highly regulated and laws are enforced by trained game wardens. Laws that pertain to fur hunting and trapping help to:

1. Protect species from becoming threatened or endangered.
2. Improve animal welfare.
3. Prevent nontarget catches.
4. Limit fur hunting and trapping to the time of the year when furs are marketable and young no longer depend on adult animals.
5. Monitor harvest levels by using harvest questionnaires.
6. Support habitat conservation and wildlife studies through license sales and other fees.
7. Protect landowners' rights and interests by requiring written permission before setting capture devices.

The North Dakota Game and Fish Department monitors wildlife populations and adjusts season dates and bag limits accordingly. A furbearer guide contains rules and regulations applicable to the year's activities. Guides may be obtained from stores that sell hunting and furbearer licenses or by contacting:

North Dakota Game and Fish Department
100 North Bismarck Expressway
Bismarck, North Dakota 58501
Phone: (701) 328-6300
(web: gf.nd.gov) (email: ndgf@nd.gov)

Confidential information concerning violations can be reported by calling 1-800-472-2121



Explain the difference between a renewable and a nonrenewable resource

Natural resources fall into one of two categories: renewable and nonrenewable. Renewable resources are living things with the capacity to regenerate or repopulate. Plants and animals are renewable resources. For example, when trees are cut down, new trees can grow there again from seeds. Similarly, when wild animals are harvested by people or die due to disease, predation or starvation, the remaining animals have young and the population increases. Trees and animals are resources that can be renewed as long as habitat is available.

Nonrenewable resources are nonliving items that are finite and do not regenerate themselves. Coal, oil and natural gas are examples of nonrenewable resources.

Identify the components of habitat and name three types of habitats used by furbearers

Wildlife habitat is made up of food, water, cover and space. Each species of wild animal needs certain kinds of food and cover. Each species also needs a certain amount of space, or habitat, to provide for its needs.

The quality and quantity of habitat in an area affects the number of species present, and the population level of each species.

Each species of wild animal is associated with a certain kind of habitat. Wetlands, forests, grasslands and farmlands are common types of habitat used by furbearers.

Arrangement is an important characteristic of habitat. When habitat types are mixed, the area generally will support more species and higher wildlife populations.

Identify two key concepts of sustainable management of wildlife resources

Native wildlife populations are natural resources - biological wealth - that must be sustained and managed for the benefit of present and future generations of people.

Wildlife biologists focus on protecting, preserving and improving habitats and ecosystems. It is important to understand that biologists also focus on maintaining sustainable populations of wildlife, not individual animals.



A tree is felled by a beaver.

USDA



FWS employee sets a cable device for problem beavers.

FWS

Wildlife populations usually are highest in the spring after young have been born.



USDA

Predator trapping has helped the endangered California least tern recover from near extinction.



FWS

Wildlife biologists face challenges

- *Human population.*
- *Public intolerance for furbearers in populated areas.*
- *Opposition to sound management by animal rights groups.*

The U.S. Department of Agriculture has a wildlife service program to manage damage, minimize wildlife threats to public health, resolve conflicts with wildlife in urban areas, protect property, protect endangered species, and preserve natural resources. Trapping is an essential tool used by wildlife service employees.

Most species of wildlife, including furbearers, have short life spans. Long term, individual animals do not endure, but populations do.

Sustainable management of furbearer populations depends upon two key concepts:

- A focus on habitat.
- A focus on the furbearer population.

Name three principles that are applied in the harvest of wild animals in North America

Biologists generally look for three requirements before allowing the harvest of wild animals:

- The species is not threatened or endangered.
- The harvest techniques are acceptable.
- Killing the animals serves a practical purpose.

Identify the major factors that affect wildlife populations

Furbearer populations change over time. Populations are highest after young are born each year. Some animals die due to weather, food supplies, diseases or predation, so the number of animals declines over the year until more are born the following year. Animal populations also change over longer periods of time, usually due to changes in the quantity and quality of habitat.

Many wild animals, including furbearers, can quickly repopulate an area of suitable habitat. River otters provide one example. In many states river otters were extirpated long ago due to unregulated killing, habitat destruction and water pollution. In recent years, some river otter habitat has been restored. Biologists and trappers captured river otters in states where the populations were high, and released them in the restored areas. Within a short time, the otter populations expanded to fill the available habitat.

The number of animals a given area can support throughout the year is known as its biological carrying capacity. Limiting factors determine what the biological carrying capacity will be. Food is a common limiting factor. Water, shelter, space, disease and predation are other types of limiting factors biologists must monitor.

Over the course of many years, furbearer populations may decline more than normal due to catastrophic events. Examples include habitat destruction such as forest fires, extreme weather such as blizzards, and diseases such as rabies. If a few animals survive, the population is capable



of recovering when conditions return to normal. During these times, biologists may restrict harvest and take other actions to help the animals or the habitat.

Explain the difference between managing furbearers for compensatory mortality and additive mortality

Biologists consider several factors when setting management goals for each furbearer species. Two of these factors include the biological carrying capacity of the habitat, and the cultural carrying capacity. Biological carrying capacity refers to the number of animals the habitat can support. Cultural carrying capacity refers to the number of animals that society will accept, which may be a lower level than the biological carrying capacity.

Under normal conditions furbearers produce a surplus of young. Wildlife managers can set seasons, bag limits and trapping methods to allow part of the annual surplus to be harvested. Biologists manage for compensatory mortality by substituting regulated trapping for other mortality factors that would otherwise reduce the population. When managed for compensatory mortality, trapping does not affect the overall population that survives until spring. If trapping did not occur, a similar number of animals would be lost due to limiting factors, such as a lack of food or shelter. The population level is determined by the biological carrying capacity of the habitat.

While some furbearer populations can change dramatically, most populations become stable when their population reaches the biological carrying capacity. In some areas high furbearer populations can cause major problems to people. Beaver dams, for example, may cause water to flood farm fields and roads, or interfere with city water supply systems. When furbearer populations cause too many problems, biologists may decide to reduce the numbers below the area's biological carrying capacity. In this case, biologists are managing for additive mortality to bring the population down to its cultural carrying capacity.

Identify regulated trapping as the most efficient and practical means available to accomplish furbearer population reductions

Regulated trapping is an important part of wildlife management programs. The regulated use of the furbearer resource is not only acceptable but in some cases has significant benefits. When furbearer populations cause conflicts with people, or with other wildlife species and habitats, biologists may adjust trapping regulations to increase the harvest to reduce the population. Regulated trapping is the most efficient and practical means available to reduce furbearer populations and it does so at no cost to the public.



FWS

While fishing is popular nationwide, some activists oppose it, along with trapping and hunting.



Excise taxes are collected on firearms, ammunition and archery equipment to support wildlife management programs.

While furbearer population reduction is not a goal for all furbearer management programs, population reduction in specific areas can be beneficial. Furbearer population control can: (1) reduce the number of furbearer problems with people; (2) lower predation on rare, threatened or endangered species; and (3) reduce damage to habitats and property.

Identify situations where trapping is used to directly manage wildlife

Regulated trapping helps manage wildlife and habitats. Trapping is used to protect many rare and endangered plants and animals, wetland habitats and personal property. Regulated trapping also is used for localized disease control, wildlife research and wildlife restoration.

In 1997 the U.S. Fish and Wildlife Service reported trapping was used on 487 management projects at 281 national wildlife refuges.

The case of the piping plover, a beach nesting bird, is a good example. The piping plover is a threatened shorebird protected by the United States and Canada. Foxes, raccoons, mink, and striped skunks prey on piping plovers when they nest. The U.S. Fish and Wildlife Service uses trapping in and around piping plover habitat to reduce local populations of these predators. Some other rare species protected by trapping programs include pink lady slippers, pitcher plants, the desert tortoise, sea turtles, Attwater's prairie chickens, brown pelicans, least terns and black-footed ferrets.

Beavers, muskrats, coyotes, raccoons, opossums, red foxes, mink and other animals often are trapped to protect habitats and personal property. Traps are the only efficient and practical tool that can be used to remove these animals.

Explain the three major issues related to furbearer management

Three major issues affect conservation and management of furbearers:

- Human population growth, which degrades and destroys habitat.
- Public intolerance of furbearers.
- Opposition to any use of wildlife by animal rights groups.

Human population growth causes the loss of furbearer habitat. The range of some furbearer populations already has been reduced. Habitat destruction has eliminated the possibility of restoring some furbearing species to areas they once inhabited. Unlike habitat destruction, regulated trapping is a sustainable use of furbearers. Trapping does not threaten the continued existence of furbearer populations.



Public intolerance of furbearers is another issue. As wildlife habitat continues to be fragmented by development, biologists are faced with new challenges. Examples include coyotes killing pets, beavers cutting landscape trees or building dams that flood roadways, raccoons invading homes, and human health threats from diseases such as rabies. These problems are highly publicized and they make some people want to lower or eliminate furbearer populations. As a result, nuisance animal trapping has become a growing industry. This is a concern because an increasing number of people identify furbearers as problems that should be destroyed. This is a reactive response to problems when regulated trapping activity is proactive and values these resources.

Animal rights activists reflect a different view, which differs from values of using animals for food, clothing and other purposes. Activists want to eliminate all trapping and stop managing furbearers. If animal rights activists are successful, people will have fewer options for solving furbearer problems. Additionally, people could not use furbearers the way they do now.

Identify two funding sources for furbearer management programs

Hunters and trappers provide most of the money for wildlife management programs. The two major sources of funding include:

- Hunting and trapping license revenues.
- Excise taxes on firearms, ammunition and archery equipment.

Hunting and trapping licenses are sold by states and provide direct revenue for furbearer management. Excise taxes on equipment are distributed by the U.S. Fish and Wildlife Service under the Division of Federal Assistance in Wildlife Restoration Act. Wildlife Restoration dollars, sometimes more than \$200 million a year, are distributed to all 50 states, territories, and Puerto Rico for approved programs that involve wildlife research, management, land purchases and education.

Chapter 3 – Furbearer Management

Content Standard - Students use knowledge of furbearer management principles, practices, and issues to explain current management programs in their state.

Identify the government agency with the authority to manage furbearer resources and regulate trapping in your state.

- Name the agency that regulates trapping in your state.

Explain the difference between a renewable and a nonrenewable resource.

- Name two renewable resources.
 1. _____
 2. _____
- Name two nonrenewable resources.
 1. _____
 2. _____

Identify the components of habitat and name three types of habitats used by furbearers.

- Name four components (parts) of habitat.
 1. _____
 2. _____
 3. _____
 4. _____
- Name three types of habitat used by furbearers.
 1. _____
 2. _____
 3. _____

Identify two key concepts of sustainable management of wildlife resources.

- Name the two key concepts of sustainable furbearer management.
 1. A focus on _____.
 2. A focus on _____.

Name three principles that are applied in the harvest of wild animals in North America.

- Complete these statements.
 1. The species is not _____.
 2. The harvest techniques are _____.
 3. The killing of the animals serves a _____.

Identify the major factors that affect wildlife populations.

- Food supplies can be a limiting factor for wildlife. Name two more limiting factors.
 1. _____
 2. _____

Explain the difference between managing furbearers for compensatory mortality and additive mortality.

- When furbearers overpopulate and cause problems, biologists may need to reduce the population. This means the biologists must manage for _____ mortality.

Identify regulated trapping as the most efficient and practical means available to accomplish regular furbearer population reductions.

- Regulated trapping is the most practical means available to reduce furbearer populations and it does so at _____ to the public.

Identify situations where trapping is used to directly manage wildlife.

- Regulated trapping is used to protect endangered species, wetland habitats, and personal property. Name three other uses for regulated trapping.
 1. Localized disease _____
 2. _____
 3. _____

Explain the three major issues related to furbearer management.

- Name the three major issues related to furbearer management.
 1. Human _____ growth.
 2. Public _____ of furbearers.
 3. Opposition from _____ groups.

Identify two funding sources for furbearer management programs.

- Name two major sources of funding for furbearer management:
 1. _____ and _____ revenues.
 2. Excise taxes on firearms, _____, and _____ equipment.

Chapter 4

Trapping Regulations



Content Standard – Students demonstrate the ability to understand, support and comply with trapping regulations.

Introduction

Biologists use hunting and trapping regulations to manage and conserve wildlife. When an animal population is low or endangered, regulations can be used to protect the species. When an animal population is high, biologists can allow more harvest, using the principle of additive mortality. If the population of a species is high enough to cause problems, biologists may lengthen the season, raise bag limits, or allow additional methods of harvest so the population can be lowered to an acceptable level.

Hunting and trapping regulations are used to enhance human health and safety and protect habitat, property and domestic animals. Regulations require the use of selective trapping methods and must meet public expectations for animal welfare.

Most states have a process for setting regulations that allows for public participation. Hunters, trappers, landowners, organizations and government agencies can participate in the regulation setting process.

As a responsible trapper, you must follow all regulations. If you disagree with a regulation you should participate in the regulation-setting process.

Each state has law enforcement officers dedicated to the enforcement of hunting and trapping regulations. They may be known as wildlife officers, conservation agents, or game wardens. Responsible trappers work with their local wildlife officers and help develop mutual respect for the role each serves in wildlife conservation. When landowners have furbearer control problems, wildlife officers often refer them to responsible trappers they know and trust.

Identify two specific places to obtain current trapping regulations

Each state wildlife agency publishes a brochure that explains current hunting and trapping regulations. A copy of this brochure should have been given to you with your fur harvester education manual.

Legal traps vary from state to state. Trapping regulations may change each year within a state.

Wildlife officers have an important job. Officers strictly enforce trapping regulations. They also may help teach trapper education courses and work on nuisance animal complaints.

Flexible trapping regulations allow biologists to use trapping as a tool of wildlife management.



Raccoon skull.

Brent Temes

It is your responsibility to know the trapping regulations. Ignorance of the law is no excuse if you are charged with a trapping violation.



Silvertip Productions

Trappers work with wildlife agencies to improve regulations.

Since trapping regulations may change each year you need to obtain a new copy of the regulations when you renew your trapping license. The most common place to find the brochures is at the location where you purchase your license. You also may obtain the regulations by writing, calling, or visiting a wildlife agency office. In addition, most states publish hunting and trapping regulations on their website. **Visit the North Dakota Game and Fish Department website at: gf.nd.gov.**

Explain the process for setting or changing trapping regulations in your state

The North Dakota Game and Fish Department is responsible for publishing the fur hunting and trapping regulations. The North Dakota Century Code and Administrative Law is the authority for these regulations. All changes to the Century Code and Administrative Law are approved by the legislature and signed to law by the governor.

The governor appoints an advisory board to receive public comment on issues related to North Dakota's natural resources. Advisory board members represent a geographic district within the boundaries of the state and hold public meetings twice each year. The meetings provide the opportunity to discuss and request actions relative to fur hunting and trapping.

Explain conditions that could lead to changes in trapping regulations

- Furbearer populations rise or fall.
- Trapping technology improves.
- The number of trappers rises or falls.
- Habitat changes.
- Nuisance animal problems increase.
- Public attitudes change.
- Rare or endangered species need protection from furbearers.

Review the current North Dakota Century Code to determine the legal restrictions for trapping nuisance animals

Chapter 20.1-07 provides information regarding the rules and penalties related to furbearing animals. Depredating furbearing animals are special circumstances and the requirements differ from those used during the fur harvest seasons. Review this material with your instructor and become familiar with these requirements.



Hunters and trappers are expected to know the regulations and follow them

Violations of a state’s hunting and trapping regulations can be criminal offenses. Conservation officers and judges recognize the difference between an unintentional violation and willful intentions to poach animals out of season or by illegal means. Ignorance of hunting and trapping laws is not an excuse.

Upon conviction of hunting or trapping violations, a judge may impose fines or jail time. Hunters and trappers convicted of serious violations may have traps, firearms and even vehicles confiscated by the court. Judges also can revoke licenses and suspend privileges to hunt or trap in the future.

Explain the process for reporting wildlife violations

As a trapper, you may learn about hunting or trapping violations that need to be stopped. Never confront a violator or get directly involved without an officer present. Instead, observe the situation and quickly report it to your local wildlife officer. Provide descriptions of the violators, vehicles, license plate numbers, locations and times.

Most states have established programs to stop poaching with toll-free telephone numbers to call when you need to report a violation. These programs go by names such as “TIP” which stands for “Turn In a Poacher” or “RAP” which stands for “Report All Poachers.” Many states provide rewards for information that leads to the arrest and conviction of violators. Callers can remain anonymous.

The North Dakota Game and Fish Department’s line is 701-328-9921.



Ohio DOW

A trapper prepares to make a submersion set for beaver.

When furbearers are too abundant, biologists can reduce restrictions on trapping.

When furbearers are too scarce, biologists can shorten seasons or take other steps to allow the population to increase.

Some states require trappers to tag traps with the owner’s name and address.



Chris Tischaefter

Metal trap tags are made from brass or copper. The information is stamped into the metal and is permanent.

Chapter 4 – Trapping Regulations

Content Standard – Students demonstrate the ability to understand, support, and comply with trapping regulations.

Identify two specific places to obtain current trapping regulations.

- Name two places to find your state’s trapping regulations.

1. _____

2. _____

Explain the process for setting or changing trapping regulations in your state.

Explain conditions that could lead to changes in trapping regulations.

- Name at least three reasons wildlife agencies might change trapping regulations.

1. _____

2. _____

3. _____

Demonstrate the use of your current state regulation brochures to find trapping seasons, legal trap types, legal trap sets and tagging requirements for common furbearers.

- Pick two furbearers that are common where you live. Use your state regulations to fill in the information about seasons and legal trap types.

Furbearer		
Season		
Legal Traps		

Demonstrate the use of your current state regulation brochures to find requirements regarding permission to trap on private property.

- Write the requirements for obtaining permission to trap on private lands.

- Fill in information about legal penalties for trapping violations.

<i>Offense</i>	<i>Maximum Fine</i>	<i>Suspension of Privileges</i>	<i>Civil or Criminal Charge</i>
<i>Trapping out of season</i>			
<i>Trapping without a license</i>			
<i>Trapping protected animals</i>			
<i>Trapping without permission</i>			
<i>Failure to tag cable devices</i>			
<i>Trespassing</i>			

Explain the process for reporting wildlife violations.

1. Never _____ a violator.
2. Safely observe the situation and report it to a _____.
3. Provide descriptions of the violators, vehicles, locations and _____.



Trapping BMPs – Sustaining the Future of Trapping.



All 50 state fish and wildlife agencies support the development of Best Management Practices.

Trappers, veterinarians and university researchers helped wildlife agencies evaluate more than 70 types of traps.

Content Standard – Students understand Best Management Practices for Trapping were created to address animal welfare, trapping efficiency, selectivity and safety in furbearer management programs.

Introduction

In 1996, the Association of Fish and Wildlife Agencies (formerly known as the International Association of Fish and Wildlife Agencies) began a program to develop Best Management Practices for trapping as a way to improve the welfare of captured animals, and to document improvements in trapping technology. This project is one of the most ambitious in the history of the conservation movement.

BMPs are necessary to sustain regulated trapping as a wildlife management tool, and to maintain the integrity of wildlife conservation programs throughout the United States.

State the name of the organization that coordinates development of Best Management Practices for trapping

The Association of Fish and Wildlife Agencies coordinates the development of BMPs for trapping. AFWA's membership includes all 50 state fish and wildlife management agencies, federal agencies, and conservation organizations.

State furbearer biologists, veterinarians, trappers and scientists from the University of Georgia and the University of Wyoming cooperated on the development of BMPs. Most funding for trapping BMP research and development was provided through a Congressional appropriation to the U. S. Department of Agriculture.

Explain that BMPs are based on scientific information and professional experience about current traps and trapping technology

BMPs are based on the most extensive research effort on animal traps ever conducted in the United States. Traps tested were selected based on knowledge of commonly used traps, previous research and input from expert trappers.



Recognize that the Trapping BMP Project is designed to provide wildlife management professionals in the United States with the data necessary to assist in improvements to animal welfare in trapping programs

Trapping BMPs were developed to give wildlife professionals information they need to improve animal welfare. State fish and wildlife agencies will use BMPs to continue the improvement of trapping systems throughout the United States.

Recognize that trapping BMPs are intended to be a practical tool for trappers and wildlife biologists to use for decision-making in the field

Trapping BMPs include suggestions on practices, equipment and techniques that will provide trappers and wildlife biologists with practical information to use in the field. These suggestions will improve animal welfare, help avoid the unintended capture of other animals, and increase public support for trapping.

Identify BMP criteria for the evaluation of trapping devices including animal welfare, efficiency, selectivity practicality and safety

BMP traps were evaluated using criteria to measure the effects on animal welfare as well as trapping efficiency, selectivity, practicality and safety.

Animal Welfare

Researchers tested live restraining traps for injuries to furbearers using two methods. One system evaluated specific injuries, and the other grouped the injuries into categories from mild to severe. BMP-approved traps must have a low rate of injuries to the furbearing animals being studied. Recommended traps resulted in moderate, low, or no injury to at least 70 percent of the animals trapped.

Efficiency

Traps meeting BMP criteria must be able to capture and hold at least 60 percent of the furbearers that spring the trap.

Selectivity

Traps must be set and used in a fashion that limits the risk of capturing nonfurbearing species while increasing the chances of capturing the desired furbearer.

Practicality

Each recommended live restraining trap was evaluated by experienced trappers and wildlife biologists for practicality. Criteria used to measure practicality included cost, ease of use,

Wildlife veterinarians examined thousands of trapped furbearers for different types of injuries.

More than 150 teams of trappers and technicians participated in field testing.

Each state wildlife agency decides how to incorporate Best Management Practices into trapper education and furbearer management programs.

BMPs are valuable tools for biologists and trappers.

BMP-recommended traps resulted in no, little, or moderate injury to at least 70 percent of the animals trapped.

Traps that failed to capture and hold at least 60 percent of the species targeted did not qualify for recommendation.



Badger.

Traps and sets must be selective.

Experienced trappers evaluated cost, ease of use, trap weight, reliability and other factors.

As new BMP information is published, it is distributed by wildlife agencies, AFWA and trapping associations in print and online.

ease of transport, storage, weight and size, reliability, versatility and the expected life-span of the trap.

Safety

Each recommended live restraining trap was evaluated for safety to the user and other people who might come into contact with the trap.

Identify where to find detailed BMP information for each furbearer

State fish and wildlife agencies have access to Trapping BMP publications as they are developed. Trappers can find all current information on Trapping BMPs at the following website:

- <http://www.furbearermgmt.org>

The Furbearer Management website is maintained by the Association of Fish and Wildlife Agencies on behalf of state fish and wildlife agencies, trappers and trapping organizations.

BMPs provide guidance to wildlife agencies and help responsible trappers make decisions in the field.

Chapter 5 – Best Management Practices

Content Standard – Students understand Best Management Practices for Trapping are needed to address animal welfare, trapping efficiency, selectivity and safety in furbearer management programs.

State the name of the organization that coordinates development of Best Management Practices for Trapping.

- State the full name of the organization known as AFWA.
-

Explain that BMPs are based upon scientific information and professional experience regarding currently available traps and trapping technology.

- Experienced _____ were deeply involved with developing Best Management Practices for Trapping.

Recognize that the Trapping BMP Project is designed to provide wildlife management professionals in the United States with the data necessary to assist in improvements to animal welfare in trapping programs.

Recognize that trapping BMPs are intended to be a practical tool for trappers and wildlife biologists to use for decision-making in the field.

- Using trapping BMPs can:
 1. Improve _____ welfare.
 2. Help avoid the unintended _____ of other animals.
 3. Increase public _____ for trapping.

Identify BMP criteria for the evaluation of trapping devices including animal welfare, efficiency, selectivity, practicality and safety.

- Be prepared to discuss the criteria for each of the five categories during class.

Identify where to find detailed BMP information for each furbearer species.

- Write down the URL address for the Furbearer Management website.
http://www._____

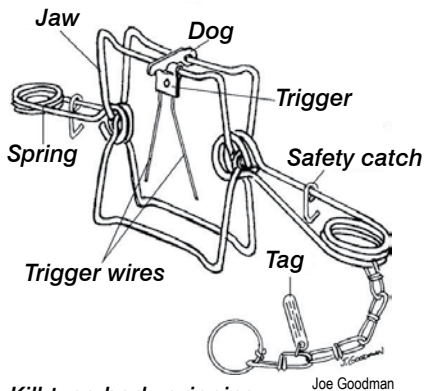

Kill-type body-gripping trap.

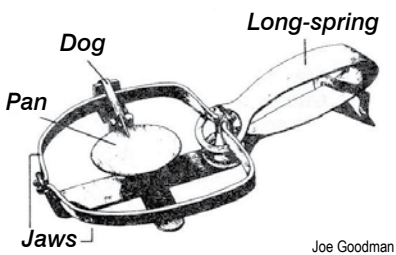

Live-restraining single long-spring trap with plain jaws.

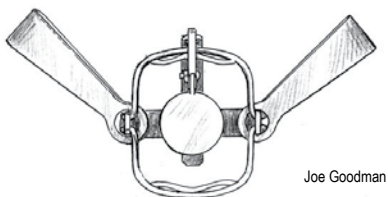

Live-restraining double long-spring double-jaw foothold trap.

Content Standard - Students demonstrate the ability to identify types of traps, prepare traps for use, and safely operate traps.

Introduction

Some traps described in this chapter may not be legal to use in your state. Regulations vary from state to state, and from year to year within states. Know the regulations for your state, and follow them.

Identify traps as kill-type or live-restraining devices

Some traps are designed to kill furbearers. The most common kill trap is a body-gripping trap, also known as a Conibear™ type trap. State regulations place limits on trap sizes and locations where sets can be made.

Live-restraining traps are designed to capture an animal alive and unharmed. The most common live-restraining traps include foothold traps, cable devices and cage traps. These traps allow you to release nontarget animals.

You also will learn how to make submersion sets using foothold traps. The proper use of submersion trapping techniques results in the death of a furbearer.

Identify live-restraining traps, including long-spring and coil-spring foothold traps, guarded traps, enclosed foothold traps, and cable devices

The most common types of foothold traps include long-spring and coil-spring traps. Foothold traps come in various sizes and strengths, each of which is appropriate for one or more specific species of furbearers. At one time trappers also used underspring traps, but this style has not been manufactured for many years.

Advantages of foothold traps include versatility, small size, and the ability to release animals. Foothold traps and cable devices are the most reliable traps for coyotes, red fox and gray fox.

Long-spring traps are the oldest type of foothold traps. Single long-spring traps are best suited for small animals like mink and muskrats. Long-spring traps are heavier than coil-springs. Double long-springs are a better choice for water sets made for large animals such as beavers.

Guarded foothold traps are used where kill-type traps are not suitable for capturing muskrats in shallow water. The spring-loaded guard restricts an animal's movement, making it less likely they will twist free or injure themselves trying to get out.

Coil-springs are the fastest kind of foothold trap. They work well in land sets for foxes and coyotes because of the coil-spring's speed, strength, and compact size.

Enclosed foothold traps are designed to catch raccoons and opossums. Traps like EGG™, Duffer's™, and Lil' Griz™ incorporate designs that almost eliminate nontarget catches because raccoons or opossums must reach through a small opening to trigger the trap.

Coil-spring activated cable devices are another kind of foothold device. These traps use 1/8-inch cable set in a loop triggered by two quick-release springs. A stop lock is used to keep the cable from closing below a certain diameter. The stop lock allows smaller nontarget animals to escape. Cables used on these traps may need to be replaced frequently due to kinking or other damage.

Identify jaw frame characteristics and modifications including plain jaws, padded jaws, offset jaws, double jaws, and laminated or wide jaws

Several BMP traps are identified by jaw frame characteristics and modifications. Padded foothold traps have rubber pads on the jaws. Some foothold trap designs for larger furbearers use offset jaws. The offset creates a space between the gripping surfaces when the jaws are closed. The offset ranges from 1/8-1/4 inch.

Double jaw traps use two metal frames instead of one. One set of jaws is smaller, and these are inside of the regular jaws.

Laminated (wide) jaws are another option that can increase efficiency and reduce injuries. Lamination expands the jaw thickness and increases the amount of surface area holding the animal's foot. Lamination normally is added by welding an additional strip of metal to the top or the bottom of the jaw that sits perfectly flush with the original jaw. Some trappers also use double lamination, welding one strip above, and one below the jaw.

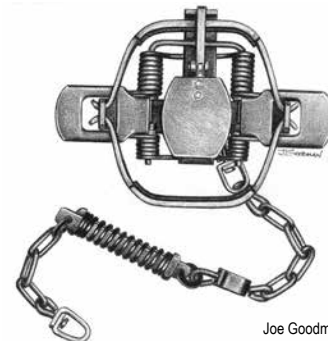

Joe Goodman

Modified coil-spring trap.

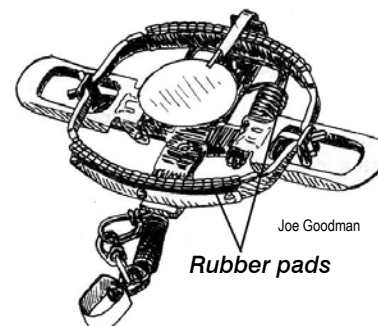

Joe Goodman

Rubber pads

Coil-spring padded foothold trap.

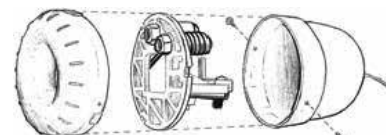

Joe Goodman

EGG™ trap.



Joe Goodman

Spring-activated foothold cable device.



Gray fox in foothold trap. Texas Parks and Wildlife

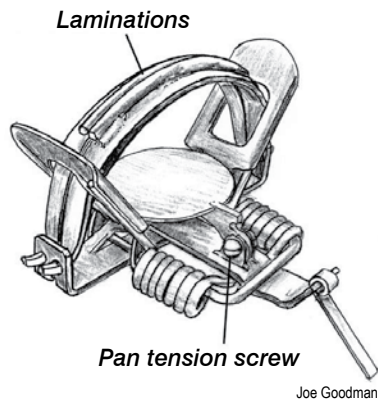

Laminated trap jaws. Joe Goodman

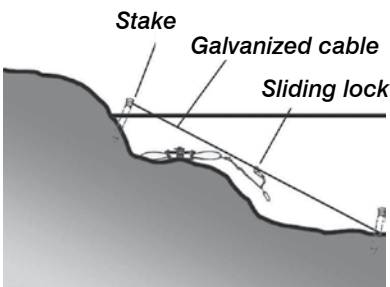

Submersion set. Silvertip Productions

Trap jaw modifications

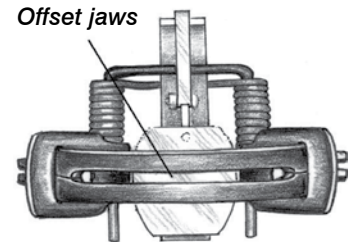
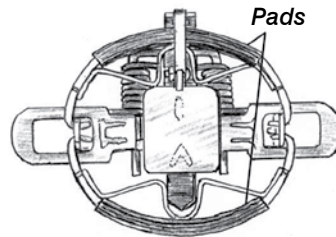

Double jaws

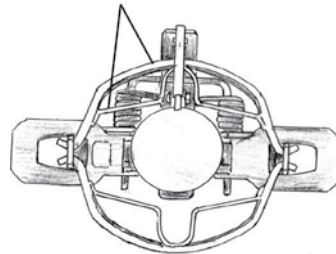

Laminations

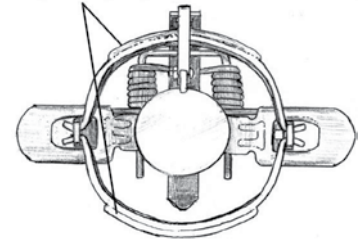

Joe Goodman

Know that foothold traps can be used in submersion sets for muskrats, mink, river otters, nutria and beavers.

Foothold traps generally are classified as “live-restraining” traps. However, foothold traps can be used in a modified set to facilitate death through submersion. To make a submersion set, use a length of galvanized cable (3/32 inch or 1/8 inch) with a one-way sliding lock. One end of the cable is staked near shore where the trap is set. The other end of the cable is staked or anchored in deep water (minimum 24 inches deep for muskrats and 42 inches deep for beavers). The one-way sliding lock allows the animal to dive toward deeper water, but not return to shore. Another option for muskrat trapping is to stake the trap in deep water. The weight of a long-spring trap will submerge a muskrat.

Advantages of using submersion.

- Ensures death of trapped animals.
- Fewer escapes and less pelt damage.
- Less chance of trap or fur theft.
- Less disturbance at the set.

Disadvantages of using submersion.

- Initial cost is higher.
- Takes more time to make the set.

Identify kill-type devices including body-gripping traps

The most common kill-type devices are body-gripping traps, also known as Conibear™ traps, named after Frank Conibear, the inventor who designed this rotating jaw trap. When an animal triggers a body-gripping trap, two rotating jaws close on the animal's neck or chest. Body-gripping traps generally are used in water sets for mink, muskrats and beavers. States normally restrict the use of body-gripping traps on land to the smaller sizes. These traps must be used with caution, especially on land, to prevent capture and death of nontarget species.

Larger body-gripping traps can pose a risk to a careless trapper. It is best to use the buddy system when trapping, especially if you are using large body-gripping traps. If you accidentally spring one on your hand or arm it can be difficult to release the trap. Use your safety equipment and keep your setting tongs within reach. You also can use a rope with a loop in one end to free yourself as described in other parts of this manual.

Identify live-restraining cage traps and kill-type colony traps for use in submersion sets

Cage traps may be difficult to use because of their size. Raccoons, skunks, opossums, fishers and weasels can be caught in cage traps. Foxes and coyotes may avoid cage traps. If you need to trap near buildings or in areas used by pets, cage traps are a good choice.

Colony traps, also known as submarine traps, are a type of cage trap designed to be used in submersion sets for muskrats and mink. It is called a colony trap because you can catch an entire family, or colony, of muskrats at one time. Check regulations before using a colony trap in your state.

Identify nonpowered cable devices, powered cable devices, relaxing locks, and nonrelaxing locks

Nonpowered cable devices consist of a cable, a lock, and a swivel. These devices catch animals by the neck or body. A cable device should be equipped with a swivel, and set in an area where a restrained furbearer will not entangle it on brush, fences or saplings. Larger furbearers such as beavers, foxes and coyotes can be caught with cable devices. Use cable devices cautiously since they could hold livestock, deer or other animals. Trappers can use a “stop” on the cable that restricts the loop from closing below a certain diameter, allowing nontarget animals to get out. The use of a “break-away” lock system allows larger animals, like cattle or deer, to break the device loose and go free.



Muskrat trappers. Silvertip Productions

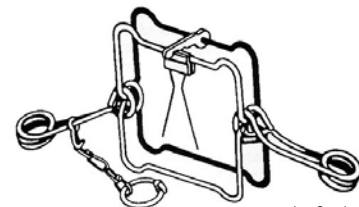

Joe Goodman

Body-gripping traps should be set to close from top to bottom to work properly.

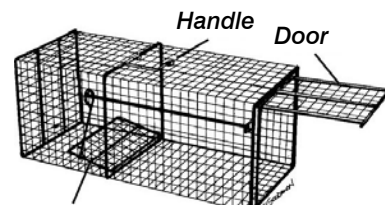

Joe Goodman

Pan trigger

Live-restraining cage trap.

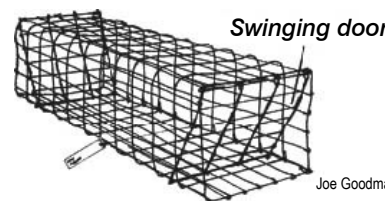

Joe Goodman

Kill-type submarine or colony trap.



Biologist with Hancock trap – a large live-trap for beavers.

Massachusetts Division
Fisheries and Wildlife

Relaxing locks move in both directions on a cable. Nonrelaxing locks only slide in one direction. If an animal pulls against the cable it gets tighter and will not release.

Powered cable devices are used to catch animals by the foot. The cable loop is mounted on a device that looks similar to a foothold trap. When the animal steps on the pan, it trips v-shaped coil-springs (similar to those found on body-gripping traps) which force the cable loop up to catch the foot. The cable loop has a stop to prevent it from closing below a certain size, so that small animals will escape. Although relatively new, this trap has been tested and approved for use in trapping Eastern coyotes as part of the BMP trap testing project.

Another type of powered cable device uses a heavy duty spring to close the cable loop tight around the neck, killing the animal like the body-gripping trap.

Identify trap anchoring systems including single stakes, cross stakes, earth anchors, drags, grapples and springs

Traps must be attached to something to hold an animal. Normally a chain is attached to a foothold trap. Trappers can use several methods to secure the chain to a stake or another object. Stakes normally are made of metal and are used to secure the chain to the ground. A stake needs to be long enough to hold the largest animal that might be caught. Under most conditions stakes should be 18-24 inches in length. Even longer stakes are needed in sandy soils. Foxes and coyotes require a more secure method to keep the captured animal from pulling the stake out. Trappers use a cross-staking method for these stronger animals. If the stakes do not hold well, you must find a new place to make your set. You must not let an animal escape with a trap on its foot because it will cause injury.



Three-pronged grapple. Chris Tischafer

Some trappers use earth anchors, attached to a cable which is driven into the ground with a tool. Earth anchors are very strong, and need to be dug out of the ground when sets are removed.

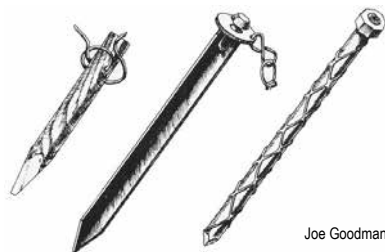

Stakes. Joe Goodman

Traps can be attached to drags in some sets. Using a drag or grapple allows the trapped animal to move a short distance from the trap site, thereby preserving the location and allowing the animal to reach heavier cover. Heavy tree limbs are a common type of drag. Grapples are metal devices secured to traps with chains. Grapples work like drags, but they are not as heavy. The shape of the metal grapple causes it to dig into the ground or vegetation, restricting the furbearer's movement.

Shock springs can be used in combination with chains, stakes, drags and grapples. One or two shock springs can be used to help hold animals, such as coyotes, that have a habit of lunging when trapped.

Explain how swivels are used and why they are important

A variety of good swivels are needed for quality sets that catch and hold certain furbearers. Swivels reduce the chance of injury by allowing a trap to move freely in the same direction as the animal's foot.

Lap-link swivels, stake swivels and universal swivels can be used to fasten a chain to a stake. When two stakes are needed trappers use a special cross-staking swivel.

Universal swivels, also called four-way swivels, can be used in the middle of chains. Universal swivels are also used in attaching the chain to a trap at the center of the base-plate.

S-hooks are used on some swivels. A special S-hook tool can be used to close the hook without damaging it. Coyote trappers weld the connection to keep it from pulling open.

Swivels of various types, including universal swivels, also are used in combination with sliding locks in submersion sets.

Always use the highest quality swivels in your trap systems to prevent an animal from escaping or being injured. The proper use of swivels is an important part of responsible trapping.

Demonstrate methods of measuring jaw spread at the dog and jaw spread at the hinge posts

There is no standardized way of determining a trap's measurements using manufacturer designations such as "No. 2" coil-spring. To find traps that meet jaw spread measurements for BMPs or state regulations you may need to check jaw spread in two places: at the jaw, and at the hinge posts.

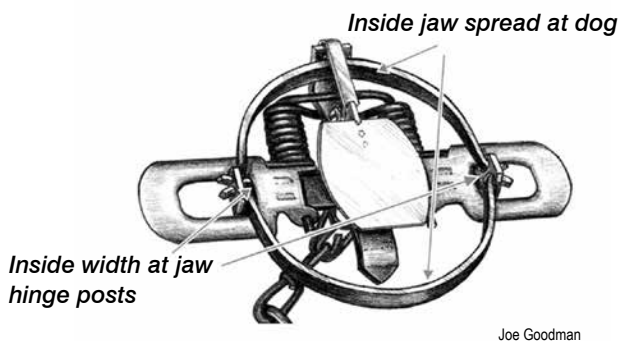

Joe Goodman



In-line shock spring. Chris Tischaefter

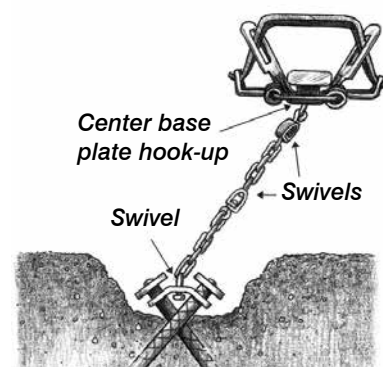

Cross-staking. Joe Goodman

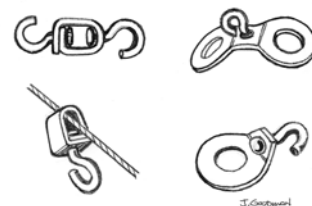

Universal and stake swivels.



Cross-staking for coyotes.



Cable device and swivel with box swivel at stake.

Trap Tuning

- Weak springs should be replaced.
- Level pan and adjust pan tension.
- Swivels and S-hooks must be strong and operate freely without binding.
- Use a metal file to smooth down any sharp or rough edges on the jaws.
- Check chains for worn links.
- Make certain your traps are tagged to comply with state regulations.

You can take these two measurements by setting the trap. Carefully measure the inside spread of the jaw frame at its widest point along the line from the dog to the opposite side. Then measure the width between the two jaws where they connect to the hinge posts. You may find slight differences in jaw spread measurements on the same make and model of traps.

Demonstrate trap-tuning procedures including the abilities to file a trap jaw to remove sharp edges, level trap pans, adjust pan tension, and adjust the pan throw

New traps require some minor adjustments to operate most efficiently. When you make these adjustments it is called “trap tuning”. You also need to inspect and tune your traps before the start of each season.

CORRECT

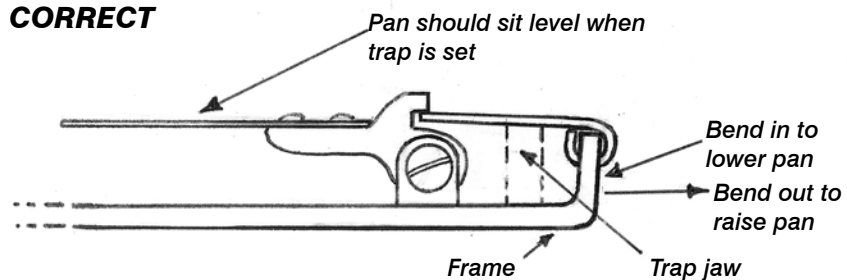

INCORRECT

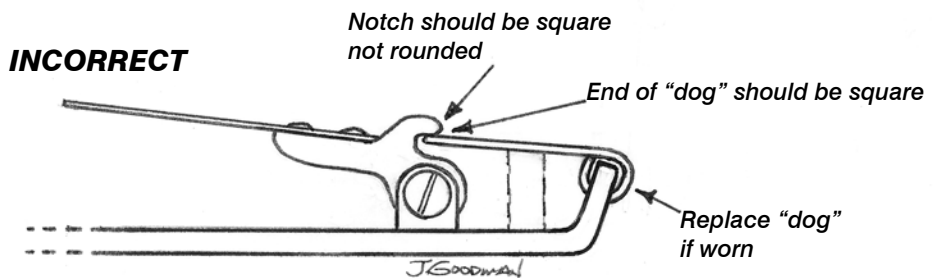

When the trap is set the trap pan should be level with the jaws. If the pan rests too high or too low you will need to bend the frame in or out below the “dog.” Bend it out to raise the pan. Bend it in to lower the pan.

Pan tension is another tuning adjustment. It is measured by the amount of weight it takes on the trap pan to fire the trap. Most new traps have pan tension adjustment screws. When trapping larger animals, increase the tension so that smaller species will not trigger the trap. For example, two pounds of pan tension is a good setting for foxes. You can purchase a commercial testing device to measure pan tension. You can also use a tennis ball can, liquid soap container, or PVC pipe filled with the weight of sand that matches your desired tension.

Pan throw is another important tuning adjustment. Pan throw is the distance the pan must be depressed to fire the trap. Use a shorter pan throw when tuning a trap for high pan tension. To adjust the pan throw, you file some metal off the end of the notch where the dog fits. This notch determines how far the pan must drop before the trap will fire. Use a file to make certain the end of the dog and the notch in the trap pan are squared off. If the dog or the notch is rounded, your trap may release too easily.

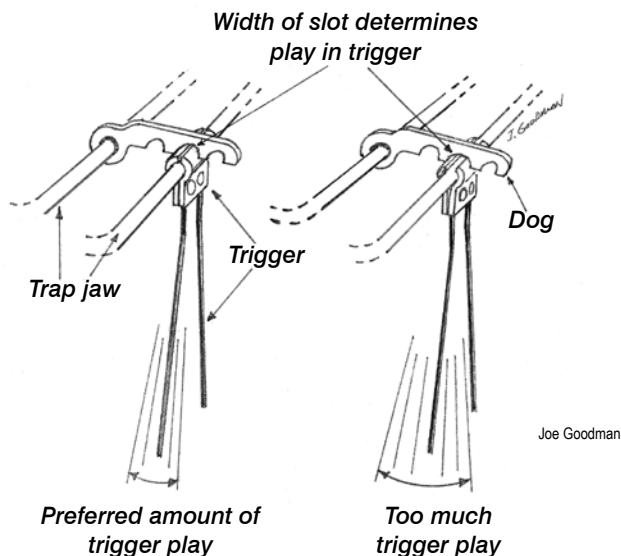

Body-gripping traps may require trigger adjustment. If there is too much play in the trigger your trap may misfire, or strike the animal in a poor location. If there is a gap in the top of the trigger assembly you can crimp it with a pair of pliers or a vise until the ends are flush.

Experienced trappers adjust the shape of triggers on body-gripping traps to make them selective for certain species of furbearers. See “Selective Trapping Techniques” chapter.



Plastic tube-like containers can be filled with sand or lead weights to create a certain known weight. Use this to test for the appropriate pan tension. Silvertip Productions

Increase pan tension by turning the pan tension screw to the right, or clockwise. Turn the pan tension screw to the left to decrease pan tension.



Trap dye and wax.

Chris Tischeafer

Explain the process and the purpose for cleaning, rusting, dyeing, and waxing new traps; and why body-gripping traps should not be waxed

New traps are shipped with a light coating of oil that needs to be removed. Put a nail or a link of the trap chain between the jaws of each trap. Put the traps in a large wash tub and fill it with water and dish washing detergent. Boil the traps in the soapy water for 30 minutes then remove and rinse them clean. Hang the traps outside until a light coating of rust forms. This may take one to two weeks. The rust will help the dye bond to the metal without hurting your traps.

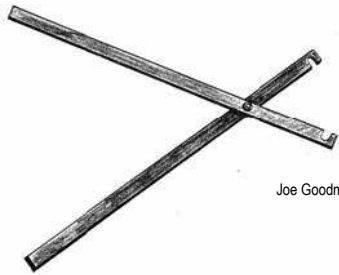
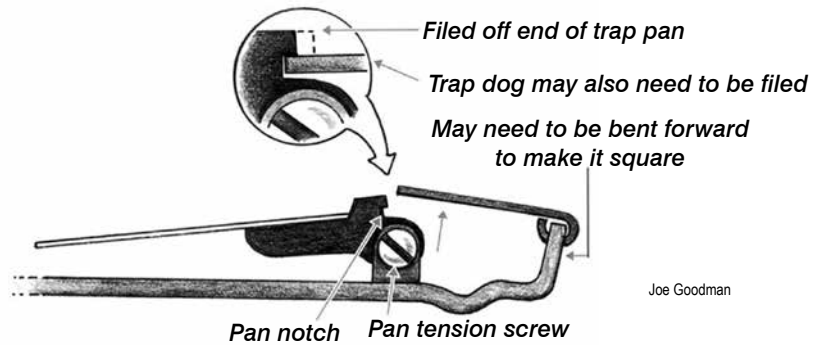

Joe Goodman

Body-grip trap setting tongs.



Joe Goodman

Body-grip trap safety gripper.

When your traps are lightly rusted they are ready to dye. Logwood powder or crystals can be used to dye traps. Put your traps in a suitable container over a fire or a propane cooker. If you use a commercial logwood dye follow the directions on the package for the proper amount of water and logwood ingredients. Bring the water to a boil before adding the logwood.

Let the traps soak in this solution for 30-60 minutes. The longer you leave the traps in the solution, the darker they will get. If the traps are heavily rusted you can take the washtub off the fire and leave the traps in the solution for a day or two.

High temperatures can weaken your trap springs so it is best to lower the water temperature to a simmer after you add the traps. A propane cooker allows you to adjust the heat easier than an open fire.

Walnut hulls and maple bark contain tannic acid, just as logwood does. As an option to buying logwood, you can boil walnut hulls or maple bark for an hour before adding your traps.

Some trappers prefer to use water based or petroleum-based dips to color and protect their traps. Note: If you are using padded jaw traps, do not dip the pads. No fire is needed with these dips. These products are fast and simple. For petroleum-based dips, add unleaded gas or lantern

fuel to the dip according to the directions. You simply dip your pre-rusted traps in this solution, and then hang them outside to dry. You will get a harder and more even coating if you use petroleum-based dips when the air temperature is above 70 degrees F. Always read and follow manufacturer's directions.

Waxing is another way to protect traps and make them operate faster. To wax traps, submerge them in boiling water. Place trap wax in the water and let it melt. The wax will float. Using a hooked stick, slowly and carefully lift the traps out of the water one at a time. The traps should come out with a thin, even coat of wax. Shake the traps to remove excess wax. If the wax is too thick or too heavy, put the traps back in the water and allow them to heat a bit longer before removing them.

Some trappers prefer to dip their traps in pure wax with no water. Exercise caution because trap wax is flammable. Wax can catch fire, or cause severe burns if it splashes on you.

Once you wax your traps, make certain you keep the wax and the container free of odors. Furbearers have a keen sense of smell. If your traps have odors on them furbearers may shy away from your sets. If the odor is an attractive one, the furbearer may dig it up and ruin your set.

Body-gripping traps require no waxing. It makes them slippery and dangerous. Petroleum based dips or dyeing is acceptable for body-gripping traps.

If you have waxed or dipped a foothold trap, you must clean the end of the dog and the pan notch. If you do not remove the dip or wax, the trap will not stay set. Use a file to clean wax or dip off of these parts.

Demonstrate how to safely set and release at least one type of foothold trap and one common kill-type device

It is important that you develop skills setting traps so that you can understand the way they work and use them safely. Working with an instructor, or an experienced trapper, select at least one type of foothold trap and practice setting it. Have your instructor or mentor show you how to release the trap safely. Practice with your instructor's help until you can do it correctly.

Single long-spring traps are easier to set than coil-spring traps. To set a coil-spring, place the palm of each hand on one of the springs. Press down evenly on both levers at the same time until the jaws open. Once the jaws are open you can hold them in place with the palm and thumb

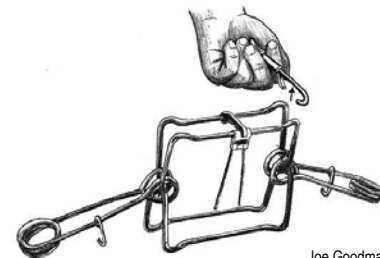

Joe Goodman

Using a safety gripper.

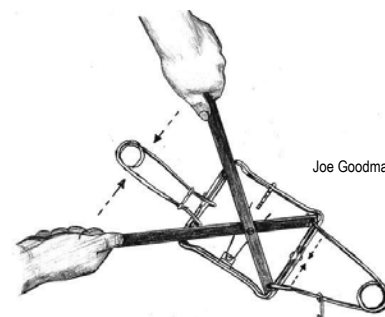

Joe Goodman

Using setting tongs.

**Using rope to set
body-gripping trap.**

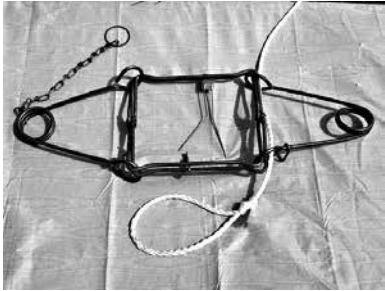

Silvertip Productions

1

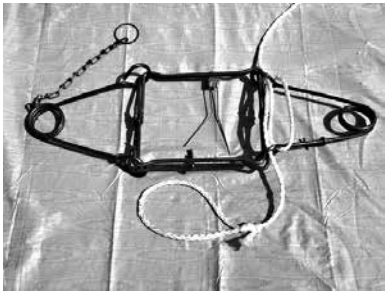

Silvertip Productions

2

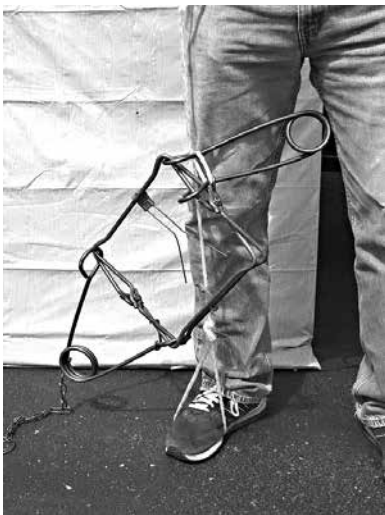

Silvertip Productions

3

of one hand. Using the thumb on your free hand, set the dog in the notch of the pan and release a little pressure on the jaws to make certain it is firmly in place. Hold the dog down with one thumb, then raise the free jaw and put your fingers below the jaw and the pan, holding the trap by the base plate. Holding the pan up, put the fingers of both hands under the jaws and the pan, and set the trap in place. With practice, you will get comfortable setting traps. On the trap line, you will need to wear gloves for warmth, and to protect the trap from human odor. It is a good idea to practice while wearing the same type of gloves you will use when making sets.

Practice setting and releasing a kill-type trap. Smaller body-gripping traps have springs that can be compressed by hand. On double-spring models you can keep the springs compressed with safety hooks that can be released once you have your trap in place.

Use setting tongs to set size 120 and larger body-gripping traps. This tool uses leverage to compress the springs and fasten the safety hook. You should use a safety gripper to keep larger traps from firing shut while you are finishing your set. Setting tongs should always be within reach when using large body-gripping traps.

A rope with a loop on one end can be used to compress the springs of a body-gripping trap. Keep this rope where you can reach it easily with one hand if you get caught. Put one foot in the loop. Run the rope through the eyes of the spring, then around the eyes and up through the eyes again. Pull on the free end of the rope with your free hand or your teeth until you can set the safety hook for that spring. Then repeat this procedure on the other spring until you relieve enough pressure to remove your hand.

Use extreme caution when setting body-gripping traps under water. If your trap is fastened below the water's surface, or below ice, you could have a difficult time freeing yourself. This is another reason to make certain you trap with a friend or relative.

Chapter 6 – Traps

Content Standard - Students demonstrate the ability to identify types of traps, prepare traps for use, and safely operate traps.

Identify traps as kill-type or live-restraining devices.

- Identify each of the following traps primarily as either kill-type or live-restraining devices.
- Body-gripping traps are _____.
- Foothold traps and cage traps are _____.

Identify live-restraining traps, including long-spring and coil-spring foothold traps, guarded traps, enclosed foothold traps, and cable devices.

- Name each of the capture devices shown below.
 - Enclosed Foothold
 - Longspring
 - Coil-spring Foothold
 - Cable Device
 - Guarded Foothold

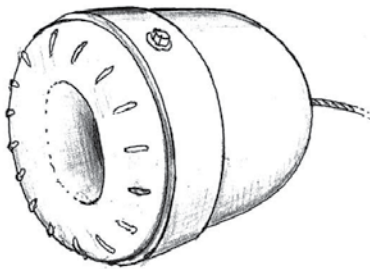

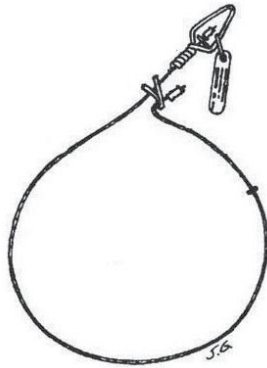

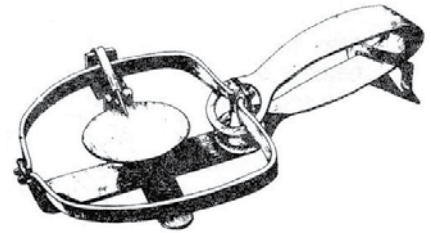

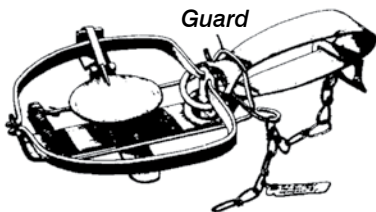

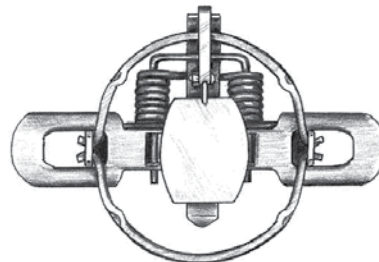

- Label the parts of the trap shown.

- A. Dog
- B. Coil-spring
- C. Pan
- D. Tag
- E. Swivel
- F. Swivel
- G. Jaw
- H. Lever

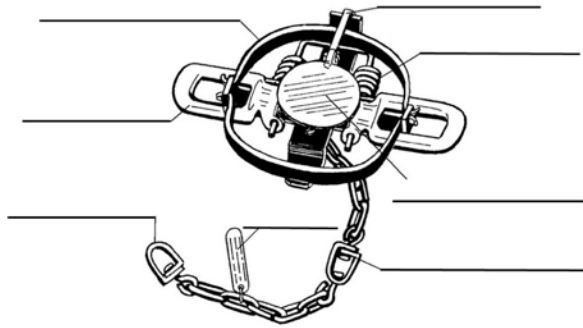

Identify jaw frame characteristics and modifications including plain jaws, padded jaws, offset jaws, double jaws, and laminated or wide jaws.

- Name each of the jaw frame types shown below.

- A. Plain Jaw
- B. Padded Jaw
- C. Offset Jaw
- D. Double Jaw
- E. Laminated Jaw

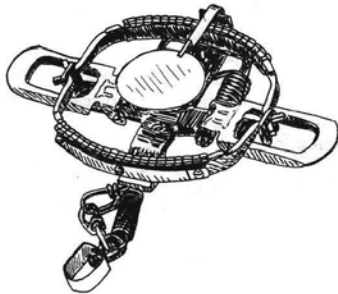

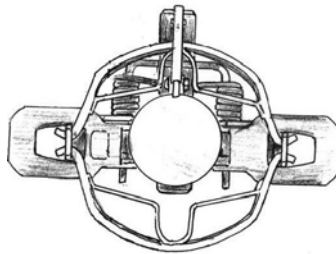

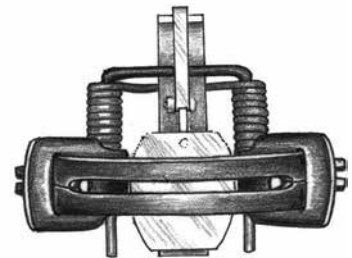

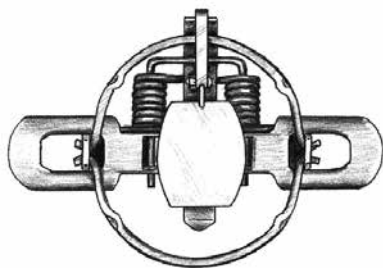

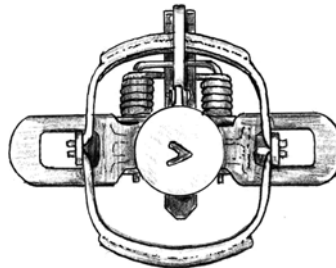

Know that foothold traps can be used in submersion sets for muskrats, mink, river otters, nutria and beavers.

- List the advantages of using submersion sets below.
 1. Ensures _____ of trapped animals.
 2. Fewer _____ and less pelt _____.
 3. Less chance of _____ of traps or _____.
 4. Less _____ at the set.

Identify kill-type devices including body-gripping traps.

- Label the parts of the body-gripping trap shown.
 - A. Dog
 - B. Jaw
 - C. Trigger
 - D. Safety Catch
 - E. Tag
 - F. Trigger Wires
 - G. Spring

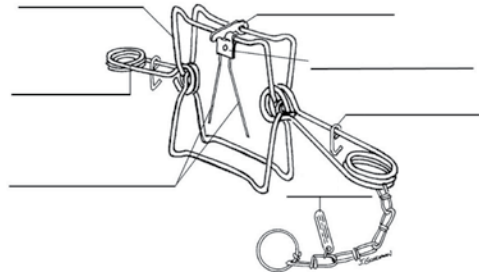

Identify live-restraining cage traps and kill-type colony traps for use in submersion sets.

- Match the two traps below with their name.
 - A. Live-restraining cage trap
 - B. Kill-type colony trap



Explain the process and the purpose for cleaning, rusting, dyeing and waxing new traps; and why body-gripping traps should not be waxed.

- Be prepared to explain the process you will use for your type of traps.

Demonstrate how to safely set and release at least one type of foothold trap and to safely set one common kill-type device.

- Be prepared to demonstrate safe trap-setting procedures in class.

Identify nonpowered cable devices, powered cable devices, relaxing locks, and nonrelaxing locks.

- Match the traps shown below with their names.
 - A. Powered cable device
 - B. Nonpowered cable device with relaxing lock
 - C. Nonpowered cable device with nonrelaxing lock



Identify trap anchoring systems including single stakes, cross stakes, earth anchors, drags, grapples and springs.

- Be prepared to identify the various staking systems with your instructor.

Explain how swivels are used and why they are important.

- Swivels reduce the chance of _____ by allowing a trap to move freely in the same direction as the animal's foot.

Demonstrate methods of measuring jaw spread at dog and jaw spread at hinge posts.

- Label the picture below as showing the measurement points for either:
 1. Jaw spread at dog.
 2. Jaw spread at hinge posts.

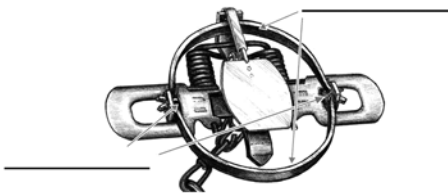

Demonstrate trap-tuning procedures including the abilities to file a trap jaw to remove sharp edges, level trap pans, adjust pan tension and adjust the pan throw.

- Be prepared to show your instructor how to tune a trap.

Chapter 7

Trapping Equipment



Content Standard – Students identify essential and nonessential equipment and clothing used to set traps and run a trap line.

Describe clothing needed for various trapping methods and weather conditions

Trappers need clothing for a variety of weather conditions. Weather conditions change over the length of a trapping season, or even during a single day spent checking your trap line.

When trapping on land you need a pair of sturdy rubber boots with soles that won't slip easily on rough terrain, snow or ice. Keep them free of unusual scents.

Dress in layers. You can remove some clothing if temperatures rise during the day. When trapping in cold weather, wool clothing is a good choice. Wool retains heat even if it gets wet. Wool allows perspiration to evaporate, so you don't get damp and cold. Thermal underwear may be needed for the coldest days.

Carry a lightweight parka or rain suit with you when you trap. Rain gear will keep you dry and block the wind.

Keep your clothes clean and free of unusual scents. Predatory animals like foxes and coyotes are especially wary of certain scents. Some kinds of clothing are noisy when you walk. If you move quietly, you will see more wildlife.

Visibility to other people is important during certain hunting seasons. Make yourself easy to see and identify. Trappers may be concerned about having their traps stolen. From a distance, most people will assume you are hunting if they see hunter-orange clothing. Your personal safety is more important than the potential loss of a few traps.

Water trappers need hip boots or waders. Shallow-water trappers can use hip boots. Chest waders are needed for deep water, and they can help keep you warm.



Trapper evaluating a stream bank for a set location.

Ohio DOW

Water trappers will need hip boots or waders.



Gauntlet gloves keep hands and arms dry when working in water.

Ohio DOW

Trappers use a variety of gloves to keep dry and warm. Some canine trappers use separate gloves for handling their traps. This keeps other scents from getting on the trap.



Shoulder gauntlets and leather gloves.

Chris Tischaefter

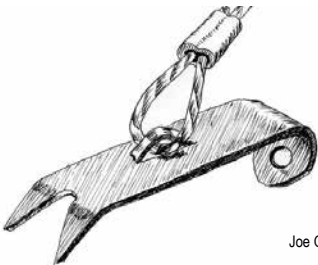

Earth anchor.

Joe Goodman

Water trappers often wear Coast Guard approved float coats. These will help keep you afloat if you fall into deep water. An inflatable personal flotation device is another water safety item you can wear. These are worn like a vest. If you need more flotation you can pull the string on an inflatable, which releases gas into the vest and expands it. A mouth tube should be available to use in case the gas canister doesn't work.

Trappers use a variety of gloves. Water trappers use long rubber gloves to protect their hands and arms from cold water. Canine trappers may use two pairs of gloves, one of which they wear only when handling traps so they keep the traps scent free.

All trappers should have warm hats. Body heat can escape through your head if you do not wear a hat. A hat also protects your head and face from sun and wind.

When you trap, carry a flashlight, ice picks, waterproof matches, firestarters, a map and a compass with you at all times. Keep them in the same place so you will know where to reach for them in an emergency.

Use a flashlight when walking in the dark, even at dawn and dusk. A flashlight will help you follow the trail and make you clearly visible to any hunters in the area. You also can use a flashlight to signal searchers if you get lost, become ill, or suffer an injury.

Identify tools, materials and supplies needed to make sets and run a trap line

First-time trappers should start out with basic gear needed to trap one or two species of furbearers. If you need to buy all new equipment, you will spend a lot of money. Learn to be successful with basic gear so you can make some spending money from fur sales before you invest too much. As you gain experience you will also learn where to get good prices on equipment and develop a better sense of the gear needed for other types of trapping.

You can purchase used equipment to save money. Be careful of buying used waders or hip boots. Old boots and waders may leak. Check used traps to make certain they are legal and in good condition before you buy them. Trap springs may weaken over time.

Trap tags

Check your state trapping regulations for requirements to tag your traps. Many states require the trapper to have his or her name and address attached to each trap.

Trap stakes & grapples

Steel stakes are needed to anchor traps. Know the length and size you need for specific furbearers and soil conditions. You may need to use grapples in certain sets.

Pliers and cable cutters

Pliers are needed for trap adjustments, plus cutting and bending wire. If aircraft cable is used for snares or anchoring systems you will also need cable cutters.

Hatchet

A hatchet is used for cutting limbs, driving stakes, chopping ice and making certain kinds of sets.

Wire or galvanized cable

Galvanized cable (3/32 or 1/8-inch) can be used to make submersion sets and fasten traps. Wire can be used to support cable devices.

Trapping staff

A staff has many uses. Use a staff to check water depths when wading, detect underwater dens, and retrieve traps from the water. A trapping staff of the proper weight and strength also can be used to dispatch animals caught in live-restraining traps.

Trowel

Trowels are used to make dirt holes or pocket sets in water.

Pack basket, bucket, or heavy bag

Any of these items can be used to carry your other equipment and traps.

Knives

Folding lock-back knives are recommended for trappers. You will find many uses for a knife on the trap line.

Dirt sifter

A dirt sifter is a frame about eight inches square and three inches deep with a quarter inch mesh screen on the bottom. The sifter is used to cover traps with fine soil. Sifters remove rocks or chunks of dirt that could interfere with the trap closing properly.



Cable cutter and pliers. Ohio DOW



Hammer and hatchets. Ohio DOW



Bucket, bag, and pack basket. Ohio DOW



Dirt sifters, gloves, stakes for land trapping. Ohio DOW



Illinois Department
of Natural Resources

Catchpole.

Many trappers work hard to avoid contaminating their trapping areas with unusual scents or human odor.

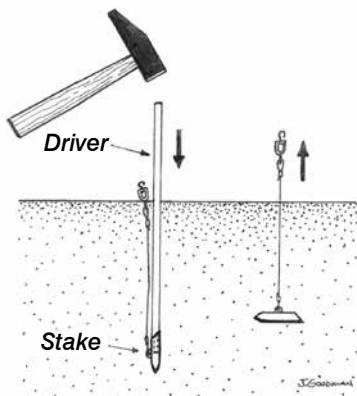

Earth anchors.

Pan covers

A pan cover is recommended to keep dirt and debris from getting under the trap pan on land sets. Wax paper, screen, plastic, and clean patches of cloth are used for pan covers.

Trapper's cap

A trapper's cap can be used instead of pan covers. This device temporarily fits over the trap pan while dirt is packed inside the jaws. When it is removed it leaves the area beneath the pan free of dirt.

Underalls

Some trappers use pieces of foam rubber or fiberglass insulation cut to the shape of the trap pan and to the thickness of the space under the pan. This is another way to keep dirt and debris from getting under the pan.

Catchpole (release noose)

A release noose is used to hold an animal so it can be safely released or dispatched. A catchpole is an essential tool for a land trapper.

Gloves

Trappers use a variety of gloves. Latex gloves are used when skinning animals. Water trappers use gauntlet gloves that cover the arm to the shoulder to keep dry in cold weather. Land trappers use rubber or cotton trap setting gloves to keep human scent off their traps.

Kneeling pad

Land trappers use cloth, canvas, or rubber pads to kneel on when making land sets. Kneeling pads help keep human odor off the set. The kneeling pad also is a good place to put dirt when digging the bed for a trap.

Spare parts

Extra swivels, S-hooks, trap tags, rivets, stake swivels, safety hooks, and other parts associated with your line.

Dry, pre-sifted dirt

Used during cold weather for dry-land foothold sets.

Gauntlets

Long rubber gloves used to keep hands and arms dry and warm when working in water.



Plastic flagging

Used to mark trap sites or other areas of interest.

Lures and baits

Keep separate from your other trapping equipment.

Setting tongs and safety gripper

For setting and placing body gripping traps.

Stabilizers

Support systems for body gripping traps.

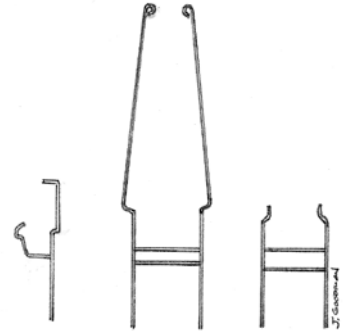

Body-grip stabilizers.

Chapter 7 – Trapping Equipment

Content Standard - Students identify essential and nonessential clothing and equipment used to set traps and run a trap line.

Describe clothing needed for various trapping methods and weather conditions.

- The clothing you will need varies by the type of trapping you will do and the climate in your area. Below, describe the primary type of trapping you will do and make a list of the clothing you will need.
- Furbearers you will trap: _____.

• Clothing you will need:

_____	_____	_____
_____	_____	_____
_____	_____	_____
_____	_____	_____
_____	_____	_____
_____	_____	_____

Identify tools, materials, and supplies needed to make sets and run a trap line.

- For the types of furbearers you will be trapping, make a list of the tools, materials, and supplies you will need:

_____	_____	_____
_____	_____	_____
_____	_____	_____
_____	_____	_____
_____	_____	_____
_____	_____	_____

Chapter 8

Using Bait, Lures and Urine



Content Standard – Students explain responsible use of lures, bait and urine to attract furbearers to sets.

Introduction

Effective use of bait, lures and urine will increase your catch and help you avoid nontarget animals. The more you learn about an animal and its habits, the better you will be at using lures, bait, and urine.

Explain when and how to use bait, glandular lures, food lures, curiosity lures, and urine to attract specific furbearers

Bait, lures, and urine can be used alone or in combinations to help you trap furbearers. Scents should match the interests of the animal you are trying to catch.

Baits are used to attract animals to your sets and make them stay longer. Your choice of bait and its placement is based on the furbearer's food source and eating habits. Baits can be chunks of meat and fish, or plant food such as corn, carrots and apples. Meat and fish bait may be fresh, tainted, or liquid in form.

Bait must be used carefully to prevent catching nontarget wildlife or domestic animals. Pay close attention to trapping regulations concerning bait. Uncovered flesh baits are attractive to hawks and owls, which hunt by sight. Lightly covered flesh baits work for furbearers because they have a keen sense of smell. Baits such as corn may attract a variety of nontarget animals.

Lures are used to attract animals to your sets from a distance. Lures are classified as gland, food, or curiosity attractants. Gland lures appeal to an animal's sexual attraction or territorial instincts. Food lures or scents appeal to their desire to eat. Curiosity lures appeal to a furbearer's instinct to investigate something unfamiliar.

Generally, food lures are most effective in the early part of the trapping season; gland lures become more important later in the season when the animals are looking for mates; and curiosity lures may work at any time in the season, especially when the animal is not hungry or looking for a mate.



Baits – canned fish, apple, and carrot.

Ohio DOW

If you find a dead animal, do not set traps there, you may catch nontarget animals. Many states have laws that restrict the distance between exposed bait and the capture device. Know the law.

Visual attractants, where legal, are sometimes used. Bobcats, for example, may be attracted to strips of cloth or pieces of metal fluttering in the breeze.



Urine and lures.

Ohio DOW

Bait and lures come in a variety of textures and smells.

Urine often is used for trapping foxes and coyotes. Like dogs, foxes and coyotes mark their territory by urinating on various objects. Urine triggers a territorial response that may encourage a coyote or fox to investigate your set.

Some trappers enjoy making their own lures and attractants. It is part of the challenge of becoming a successful trapper. Commercial lures work, but if a certain kind is used frequently animals may become wise to the scent and avoid it.

The use of bait, lures and urine varies by time of year, location, and the type of furbearer you want to catch. The presence of nontarget species or domestic animals also will affect your choice. The responsible use of bait, lures and urine can make you more successful catching furbearers while avoiding problems with nontarget animals. Remember, each nontarget animal that comes to your set reduces your chances of catching the animal you want.

Chapter 8 - Using Baits, Lures and Urine

Content Standard - Students explain responsible use of lures, baits and urine to attract furbearers to sets.

Explain when and how to use bait, glandular lures, food lures, curiosity lures and urine to attract specific furbearers.

- List three furbearers common to the area you will be trapping. List any bait, lures, or urine you will use at your sets, if needed. Your choices should result in selective sets to attract the furbearers you want and avoid nontarget animals.

Furbearer	Bait	Lure	Urine

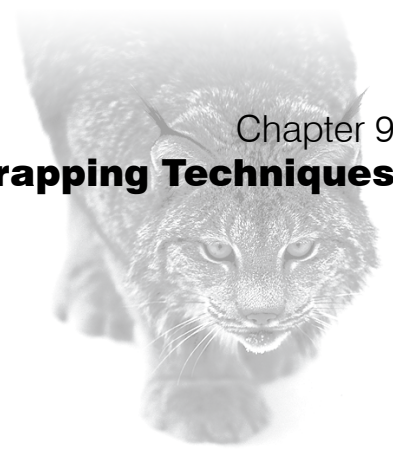

FWS employees use selective techniques for research.

FWS



Rock cubby.

Ohio DOW

Content Standard – Students demonstrate an understanding of trapping principles and techniques that increase selectivity of sets.

Introduction

Trapping is a challenging activity. Each time you set a trap, make the set to catch a specific furbearer. You also should take steps to prevent catching pets or other nontarget animals. This is known as selective trapping.

Information on in this chapter will give you an introduction to selective trapping techniques in preparation for further understanding the chapters on making sets.

Use knowledge of furbearers and their habits to select the best locations and make selective sets

Trap location is the first consideration for selective trapping. Each species of furbearer lives in a certain kind of habitat, eats certain kinds of food, and follows certain habits. Use this knowledge to find the best places to set your traps.

Describe the use of sticks, rocks, or other material to guide target animals to a trap or divert nontarget animals away from traps

Sticks and rocks can help you make selective sets. Examples include:

- If you make a muskrat set at the edge of a stream you can avoid ducks and other water birds by sticking branches out of the stream bank above the trap. Muskrats can pass below the branches.
- You can make a rock cubby for raccoons that will keep most dogs from approaching the trap.
- A few small stones can be used as foot guides at land sets to help make the animal put its foot on the trap.

Describe the use of baits and lures that attract a target species and avoid nontarget animals

The use of bait, lures and urine is a key factor in selective trapping. Each furbearing animal will respond to certain food smells. Glandular lures can appeal to a specific animal's mating urges. Never use pet food for bait. Avoid other baits that might attract dogs or cats. For example, fish might attract cats if you are trapping near homes that have pets.



Explain that properly tuned BMP traps have been tested for selectivity and efficiency

Selecting the proper trap is made easier by studying the BMPs for each species. The size of the jaw spread and strength of the spring can help catch and hold a specific furbearer. Pan tension is an important consideration as well. Try one pound of pan tension for gray fox, two pounds for red fox or bobcats, four pounds for coyotes, and six pounds for beavers.

Use BMP-recommended traps and tune them for the specific species of furbearer you want to catch. BMP traps have been tested extensively for selectivity and efficiency.

Describe the importance of avoiding trails and other areas used by livestock, domestic animals, nontarget wildlife, and humans

Although furbearers may use trails that are shared by people, pets and livestock, these are not good places to set traps. Look for more remote places to make your sets. Avoid trapping a property when you know that hunters and dogs will be out for pheasants, ducks, grouse, raccoons, or other species commonly hunted with dogs.

Explain the importance of discussions with landowners and people who regularly use private lands where you intend to trap

Responsible trappers make an effort to learn all they can about property they trap and who might be using the property for other activities. Find out who else has permission to be on the property and when they will be there. This will help you avoid problems and you may make some new friends in the process.

Explain the importance of planning when, where, and how to trap on public land to avoid catching hunting dogs

Public areas provide millions of acres of land and water where trapping is permitted. During times of heavy public use for hunting it is a good idea to focus on water trapping to avoid catching dogs. Since most furbearers are nocturnal you can make sets in the evening and pull them or trip them the next morning. Local managers, rangers, or wildlife officers can tell you about the most heavily used hunting areas so that you can avoid them when hunters are running dogs.

Explain how variations in trap placement at a dirt-hole set can increase selectivity

Trap placement in relation to lures, bait, or other attractors is another factor in selective trapping. At a dirt-hole set, for example, try placing the trap 7 inches from the hole for fox, and 12 inches for larger coyotes. This will vary some as to where the bait or lures are placed.

See the "Traps" chapter for information on tuning traps and setting pan tension.



Ohio DOW

Avoid trails used by people and domestic animals.



Chris Tischaefel

Happy young trapper.

Experiences like these last a lifetime.

Use the selectivity matrix in Appendix A to identify techniques relative to capture device type and design.



Trap placement is an important selectivity consideration. Ohio DOW

Avoid trapping in any area where people regularly exercise pets.

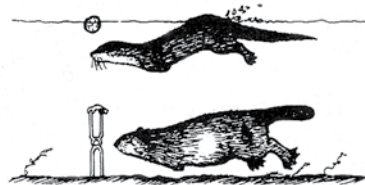

Wisconsin Department of Natural Resources

Setting bodygrip traps deep under water may allow an otter to go over the top of the trap, while most beavers will dive to the bottom and be caught.

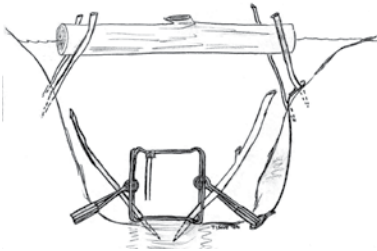

Rick Tischaefer

These are just a few examples of the ways you can make your sets selective and avoid nontarget catches. Study BMP documents for the species you trap to learn more.

Explain how trigger configurations on body-gripping traps can increase selectivity

Trappers bend the triggers on body-gripping traps as needed to make them selective. Triggers can be shaped to allow “streamlined” otters to swim through large body-gripping traps and still catch beavers, which have bigger bodies. The following images show some common trigger configurations used by trappers.

Trigger Configurations

Note: Trappers often set body-gripping traps with triggers on the bottom to reduce pelt damage to the upper part of the pelt.

Small - for mink

Small - for muskrats

Medium - for raccoon and fisher

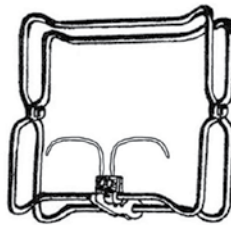

Small – for mink

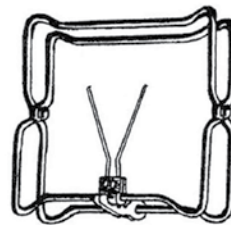

Small – for muskrats

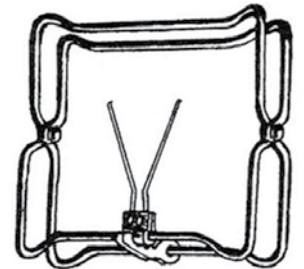

Medium – for raccoon and fisher

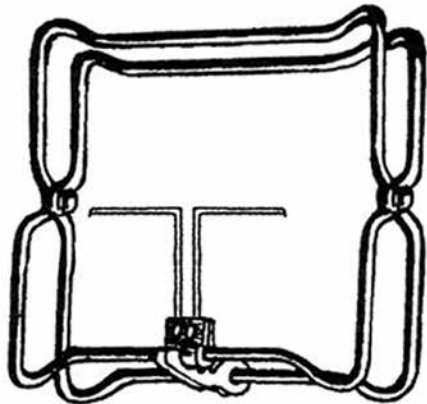

Large – beavers and otters

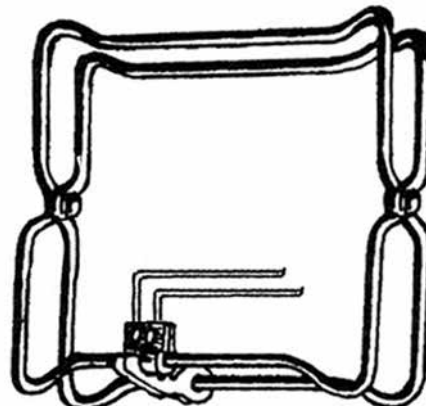

Large – beaver, not otters

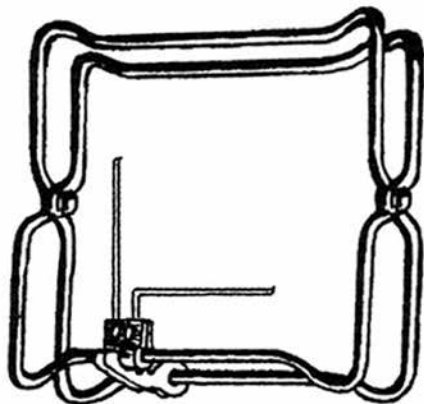

Large – beavers, not otters

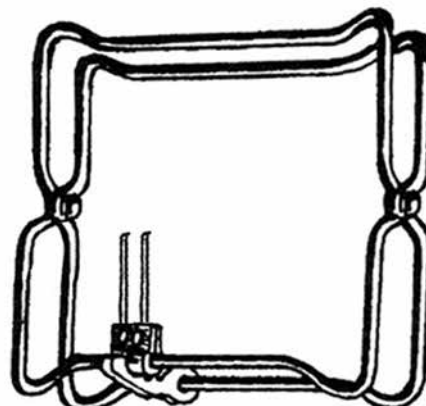

*Large – beavers, not otters
Note: triggers are cut short*

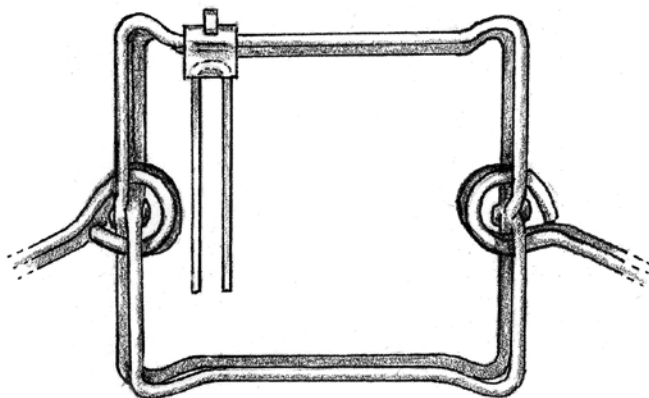

Large – beavers, not otters

Trigger Configuration Illustrations by Joe Goodman

Chapter 9 – Selective Trapping Techniques

Content Standard - Students demonstrate an understanding of trapping principles and techniques that increase selectivity of sets.

Use knowledge of furbearers and their habits to select the best locations and make selective sets.

- Select three furbearers common to your area that you are likely to trap. Briefly describe their habitat, food and habits that will help you make selective sets. Refer to the information in chapters 9 and 18 for this information.

Furbearer	Habitat	Food	Habits

Describe the use of sticks, rocks, or other material to guide target animals to a trap or divert nontarget animals away from traps.

- If you make a muskrat set at the edge of a stream you can avoid ducks and other water birds by _____ above the trap.

Describe the use of baits and lures that attract a target species and avoid nontarget animals.

Explain that properly tuned BMP traps have been tested for selectivity and efficiency.

- Pan tension is one important consideration for tuning traps. List the recommended pan tension for these species:
 Red foxes _____ Coyotes _____ Beavers _____

Describe the importance of avoiding trails and other areas used by livestock, domestic animals, nontarget wildlife, and humans.

- Be prepared to discuss the reasons why it is important to avoid these locations in class.

Explain the importance of discussions with landowners and people who regularly use private lands where you intend to trap.

- Describe the area where you will trap (private farm, public hunting area, your own land, leased land, etc.). List the kinds of activities other people may be doing there during the trapping season (bowhunting, duck hunting, camping, etc.)

Type of area you will trap: _____

Other people's activities: _____

Explain the importance of planning when, where, and how to trap on public land to avoid catching hunting dogs.

- List the types of hunting in your area where hunters are likely to be using dogs (raccoon hunting, pheasant hunting, etc.) If you are not sure, ask your family, friends, or instructors to help.

Explain how variations in trap placement at a dirt-hole set can increase selectivity.

- At a dirt-hole set, try placing the trap _____ inches from the hole for fox, and _____ inches for coyotes.

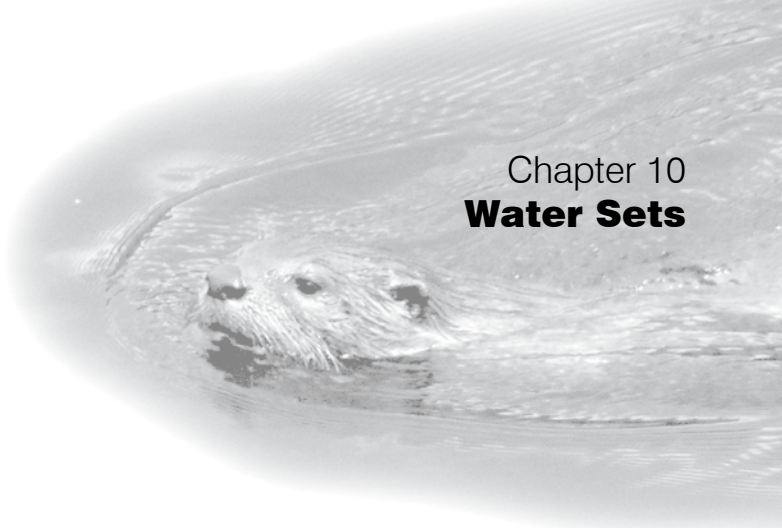

Blind set for a mink.

Illinois Department
of Natural Resources

Content Standard – Students demonstrate an understanding of the procedures for making safe, effective and selective sets in or near water.

Introduction

First-time trappers can focus on water sets for mink and muskrats. This is an excellent way to gain knowledge and experience while using a minimal amount of equipment.

Water trapping saves on startup expenses and avoids most nontarget animals. It also avoids the need to dispatch animals held in footholds or other live-restraining devices. When a trapper becomes skilled at trapping muskrats and mink, additional equipment can be purchased to use for larger furbearers such as foxes, coyotes, raccoons, beavers and otters. In general, equipment used for these furbearers is more expensive than the small traps used for muskrats and mink.

Explain the benefits of using traps that meet Best Management Practice specifications for water sets

Trappers, biologists, veterinarians, and researchers have evaluated many traps. BMP traps have been tested for:

- Animal welfare.
- Efficient ability to capture and hold animals.
- Selectivity for furbearers.
- Practical use in the field.
- Trapper safety concerns.

Describe three reasons new trappers should start with water sets using kill-type traps or submersion trapping techniques

Body-gripping traps of suitable size or foot-holds in a submersion set should be used whenever possible for water trapping. Colony traps and cable devices also are used for water sets.

It is beneficial for first-time trappers to start with water sets as they are easier to make than dry land sets. Due to the location of the sets, water trapping is selective for semi-aquatic species and avoids most nontarget animals.



The use of body-gripping traps and properly made submersion sets results in the animal's death. This prevents trappers from having to dispatch animals. Additionally, these sets make it unlikely that a furbearer will escape.

Submersion sets frequently are used for semi-aquatic furbearers (muskrats, mink, river otters, beavers, and nutria). Semi-aquatic furbearers in or near the water tend to dive below the surface of the water as a "flight" response to danger. Properly made submersion sets allow the captured animal to dive but not return to the surface. The lack of oxygen causes the animal to die.

Describe two basic techniques for making submersion sets

Use submersion trapping techniques whenever possible for semi-aquatic furbearers such as muskrats, mink, beavers, nutria, and river otters. Two techniques for making submersion sets with foothold traps are:

- Sliding cable technique.
- Tangle stake technique.

The sliding cable technique allows you to take advantage of the furbearer's "flight" response to danger by diving under the surface of the water. Make the set as follows:

- Cut a length of galvanized cable (long enough for the captured animal to reach deep water) and slide a "one way" lock onto the cable. Use double ferrules to make closed loops on each end of the cable. Make sure the sliding lock points toward the deeper water. (The lock will prevent the animal from swimming back.)
- Use a heavy object for an anchor or use a stake you can push into the stream bed in deep water.
- Slide a stake through the closed loop on one end of the cable.
- Put the anchor or the stake in water deep enough to fully submerge the intended furbearer.

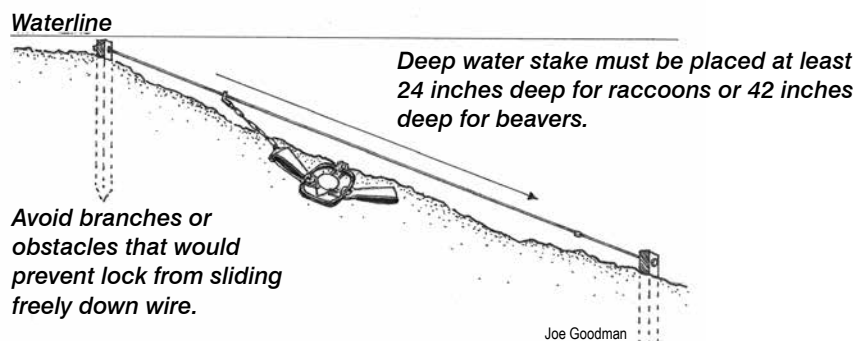

Small body-gripping traps are good choices for trapping muskrat and mink in shallow water. Set body-gripping traps at the entrance to a muskrat den, in a muskrat channel, or at the entrance to a pocket you create in the bank.

Guarded foothold traps are sometimes used for muskrat trapping where kill-type traps are not usable and the water is too shallow for a submersion set. The guard is designed to prevent muskrats from escaping.

Submersion set – before the set is finished push the stake the rest of the way into the ground at the water's edge to keep the animal from tangling on the stake.

Sliding cable anchor – You can use a heavy object or a stake to anchor the sliding cable in deep water.

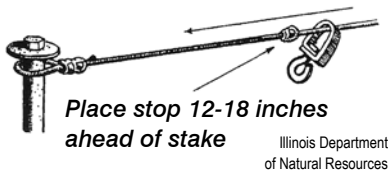

Submersion system end.

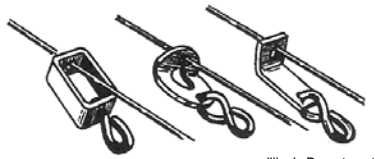

Submersion system locks.

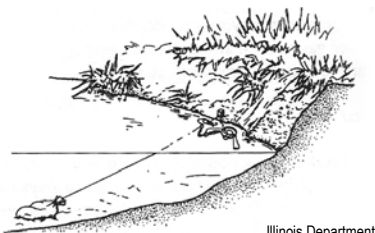

Submersion system weight.



Muskrat hut.

Some states restrict trapping near muskrat lodges. Know the regulations for your state.

- Bring the cable to the shoreline (making sure the sliding lock is in the correct direction) and slide a stake through the closed loop on this end. Drive the stake in the bank near your set so that the cable is tight.
- Make your set.

When the animal is trapped it will dive to deep water and be unable to return to the surface. You can make a tangle cable set as follows:

- Attach a length of cable to a long stake.
- Attach the trap chain to the cable with a S-hook.
- Stake the trap securely in deep water, put another stake on the deep side of the first stake.
- When the animal swims the cable will force it to swim in a circle, wrapping the cable around the two stakes; the weight of the trap will soon pull the animal under.

A special muskrat trap, called a colony trap, also is used for submersion sets.

Explain or demonstrate the procedures for making three common water sets and name the furbearers that can be captured in them

Runway set

When muskrats travel back and forth in shallow water they create a runway in the mud. Colony traps are a special type of cage trap designed to catch muskrats in a runway and keep them submerged. You can catch several muskrats at a time in a colony trap. There is a swinging door on each end. The door opens easily when a muskrat travels the runway. The door falls closed after the muskrat enters. Make certain the water is deep enough to keep the muskrats from sticking their noses out the top of the trap to breathe. During cold weather water levels may drop a bit at night because some water sources may freeze. In this situation, make sure colony traps are a few inches below the daytime water level.

Body-gripping traps also are used in runways. You can set more than one trap per runway if it's long and well defined, but space them so that the captured animal doesn't trigger nearby traps. Runways may easily be spotted through clear ice as there will be a trail of small bubbles defining the travelway.

Pocket set

A pocket set is one of the most effective water sets for muskrats and mink. To make a pocket set, find a bank that is straight up and down. At the waterline start digging a pocket into the bank at a level where the bottom will be about two inches below the water. The pocket should extend one to two feet into the bank and angle up. Put the bait or lure above the water level at the back of the pocket.

The pocket should be about six inches in diameter for muskrats or mink. Set a body-gripping or foothold trap of the correct size for the animal you plan to catch.

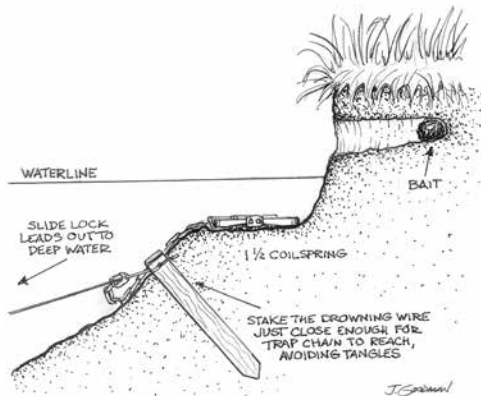

Pocket set

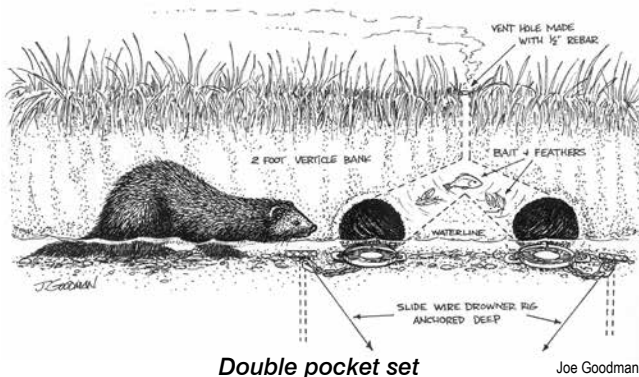

Double pocket set

Joe Goodman

The trap can be placed at the mouth of the hole in case the animal doesn't want to go all the way inside. If you are in an area where dogs may be a concern do not use meat or fish bait. To avoid dogs you can place the trap well inside the pocket, or make the set under cover such as low-hanging branches or exposed tree roots.



Joe Goodman



Dig pocket at water line.

Ohio DOW



Shave bank on both sides.

Ohio DOW



Put bait in pocket.

Ohio DOW



Place trap at pocket mouth.

Ohio DOW



Beaver take out – an area used by beavers and otters to enter or exit the water.

Brent Ternes



Beaver dam.

Brent Ternes

Trail set (blind or natural set)

Furbearers use the same trails at the water's edge on a regular basis. Find a narrow spot on the trail to make your set. If you don't find a natural place for a trail set use logs or rocks to narrow the path.

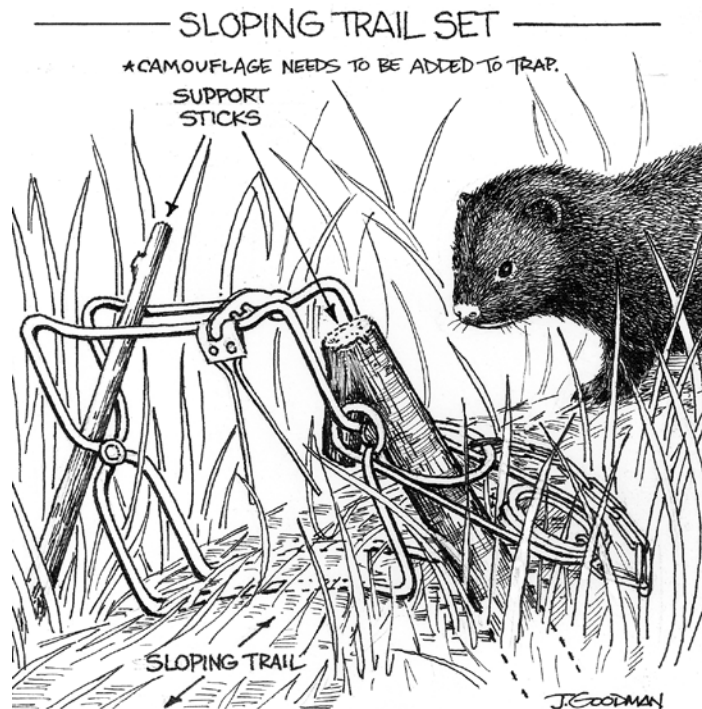

When setting in water, dig a shallow depression in the bank at the narrow spot. Set a foot-hold trap in the depression, bedding it firmly into the mud. Use the sliding cable or tangle stake technique to make it a submersion set.

You do not need to use lures or bait on a trail set. Trail sets are effective for muskrats, raccoons, mink, beavers and otters.

Cubby set

Cubby sets are used for mink and muskrats where the bank slopes too much to make a pocket set. If you find tracks on a sloping bank, make a cubby out of rocks, logs, or old boards. Place your bait or lures at the back of the cubby. You can use your foot or a trowel to make a depression for your foothold trap at the entrance to the cubby. Use a submersion trapping technique with a slide cable or a tangle stake.

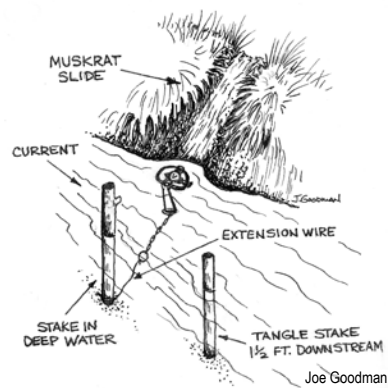

Muskrat slide.

Joe Goodman

Muskrat lodge or bank hole set

Musk rats make dens on the banks of streams, rivers, lakes, and ponds just under the surface of the water. If you see chewed up pieces of vegetation floating on the water, look for a den nearby. Musk rats also make lodges out of cattails or reeds in shallow water marshes. You will find openings around the base of the hut where you can make den sets. When iced over, den entrances will be identified by small bubbles. As the furbearer swims from the lodge or bank den, air within the fur is compressed out and floats to the surface and collects on the underside of the ice.

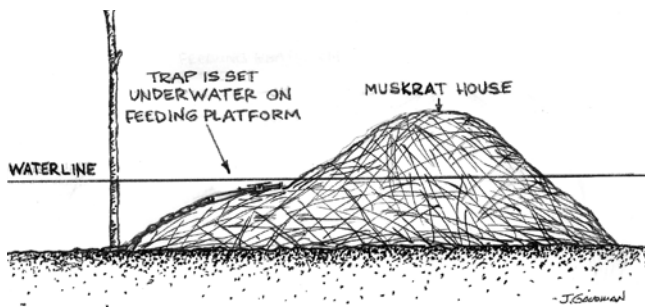

Muskrat lodge set.

Body-gripping traps are the best choice for these sets. You can place small sticks in the upper jaws of the trap to hold it in an upright position.

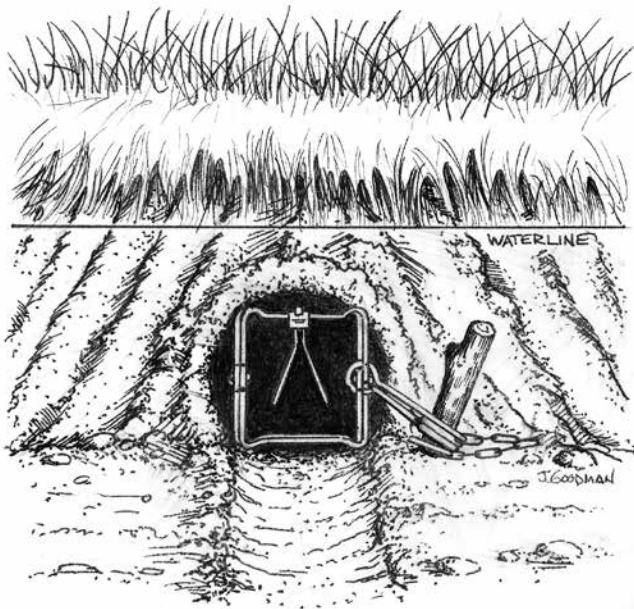

Muskrat bank den set.



Narrow place for a trail set.

Ohio DOW



Cubby – make the sides first.

Ohio DOW



Make the top of the cubby.

Ohio DOW



Place trap at entrance.
Use bait or lures and
submersion techniques
with cubby sets. Ohio DOW



Muskrat den. Ohio DOW



Den set – body-gripping
trap. Ohio DOW



Den set – sticks
hold trap. Ohio DOW

In preparation for winter, muskrats create push-ups for use after the water freezes. Push-ups look like miniature muskrat lodges and usually are only large enough for one muskrat. Muskrats use these to temporarily get out of the water and for shelter while feeding.

Carefully access the push-ups and place a foothold trap on the small platform within the enclosure. Reseal the opening after each visit and when your trap is removed. The push-ups and lodges are critical habitat and important to the survival of the remaining muskrats.

Climb-out set

Muskrats, beavers, otters and nutria leave distinct trails, sometimes called slides, at the spot where they climb out of the water to feed. You can put a foothold trap just under the water where the slide enters. Use a tangle stake or sliding cable submersion technique. If there are many slides in a certain area, use bait or lure to encourage use of the slide protected with the trap.

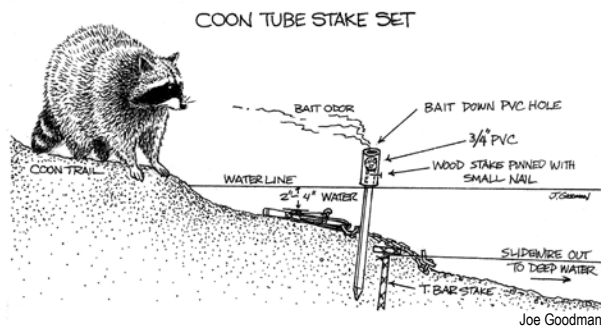

Float set

Muskrats often climb onto floating logs. You can take advantage of this habit by setting traps on logs or homemade platforms.

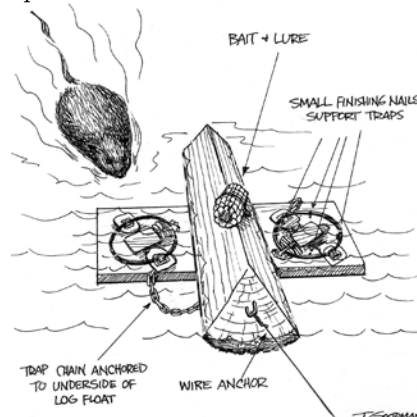

Make float sets in water more than a foot deep. Use muskrat size foothold traps on a chain or cable. When the muskrat is trapped it will enter the water and the weight of the trap will prevent the muskrat from reaching the surface. Place branches or sticks over the top of the trap to keep ducks or other birds from using the same float.

Spring run set

The place where a spring run or small stream enters a larger body of water is a good place to trap muskrats, mink, or otters. Use a foothold trap and submersion techniques.

Obstruction set

An obstruction set is a variation of a trail set. Look for a tangle of tree roots, log piles, or similar obstructions on the bank that forces a mink traveling the water's edge to enter the shallow water. You can bed a foothold trap at these points with a tangle stake or sliding cable submersion rig. This is a blind set and no bait or lures are needed.

Scent mound set

Beavers make mounds of mud and mark them with castor. Conceal beaver-sized foothold traps with a securely staked sliding cable submersion rig. If beavers are using the waterway, make a scent mound to imitate beaver activity and mark it with castor lure. This set can be effective in both late fall and spring.

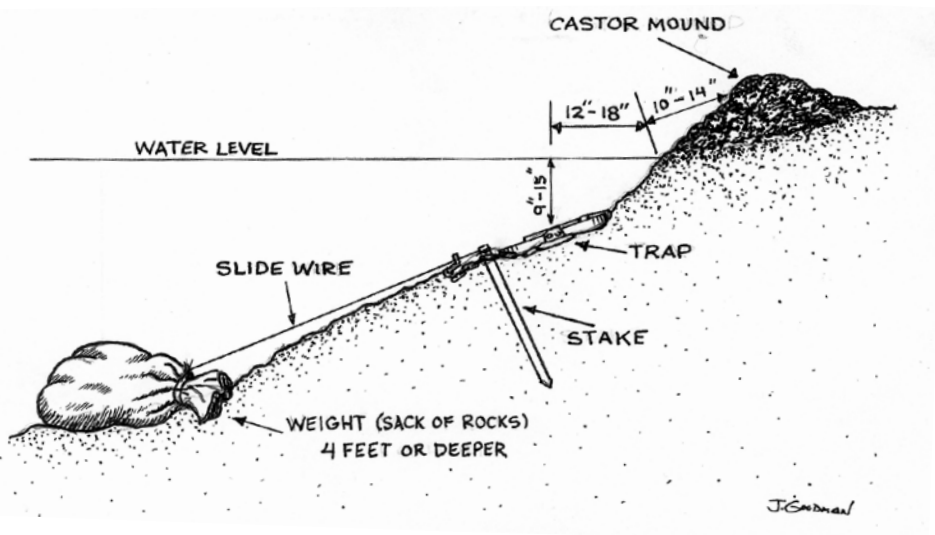

Channel set

Muskrats, mink, otters and beavers follow paths under the water called channels. This is a good place to set a submerged body-gripping trap. These furbearers regularly enter confined spaces so they don't usually shy away from a body-gripping trap in their path.



Castor mound set with body-grip trap.

Chris Tischaefel



Body-grip trap with a beaver. Proper trigger configuration allows the trap jaws to close on the body just behind the head.

Chris Tischaefel



Prairie beaver dam.

Brent Temes

Use body-gripping traps with bent corners to reduce fur damage.



Joe Goodman

Set body-gripping traps so that the trigger is on the bottom to reduce fur damage.

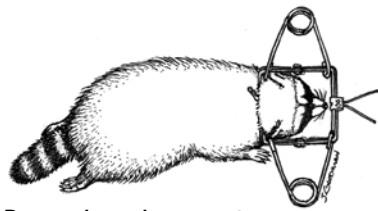

Proper jaw placement.

Body-gripping traps with weak springs can cause fur damage.

If an animal is frozen in a body-gripping trap, thaw it before removal to prevent fur damage.

Making a set under the ice for beaver is not for beginners. Find someone experienced to help you. Always trap with a friend or family member, especially when you are using large body-gripping traps and working on ice!

Place the trap at the bottom of the channel. If the channel is too wide you can arrange sticks or brush in a way to narrow the path and guide the furbearer into the trap. Use a blocking pole across the top of the trap to make the animal dive below it. Stakes and sticks are used to anchor the body-gripping trap and position it correctly in the channel.

Open water beaver set

An open water beaver set is made like a scent mound set, except that it is baited with fresh poplar and food lure instead of a castor-based lure. The set imitates a location where a beaver leaves the water to eat and rest.

Otter latrine

Otters regularly visit certain spots near the water called latrines. You will see piles of scat containing fish scales and bones at otter latrines. Set a foothold trap in 3-4 inches of water at the spot where the otter would enter or exit the water. Use a sliding cable submersion technique.

Under ice beaver bait set

You can catch beavers under ice using foothold or body-gripping traps. Make sure the ice is safe and have someone with you when you make these sets in case you need help.

Chop a hole in the ice near a beaver den. Some states have a minimum distance the trap must be set away from the den, so check the regulations. Attach the trap and the bait to a long pole and push it deep down into the mud under the water. The pole should extend well out of the ice. A trapped beaver should not be able to reach the hole in the ice where it can breathe.

Chapter 10 – Water Sets

Content Standard – Students demonstrate an understanding of the procedures for making safe, effective, and selective sets in or near water.

Explain the benefits of using traps that meet Best Management Practice specifications for water sets.

- BMP traps have been tested for:
 1. _____ welfare.
 2. _____ ability to capture and hold animals.
 3. _____ for furbearers.
 4. _____ use in the field.
 5. Trapper _____ concerns.

Describe three reasons new trappers should start with water sets using kill-type traps or submersion trapping techniques.

1. No need to carry a _____.
2. Reduces chances of catching a _____ animal.
3. Less chance an animal will _____.

List two techniques for making submersion sets. Be prepared to demonstrate these techniques, or describe them, for your instructor.

1. _____
2. _____

Explain or demonstrate the procedures for making three common water sets and name the furbearers that can be captured in them.

- Be prepared to demonstrate the procedures for making three common water sets, or describe them for your instructor.

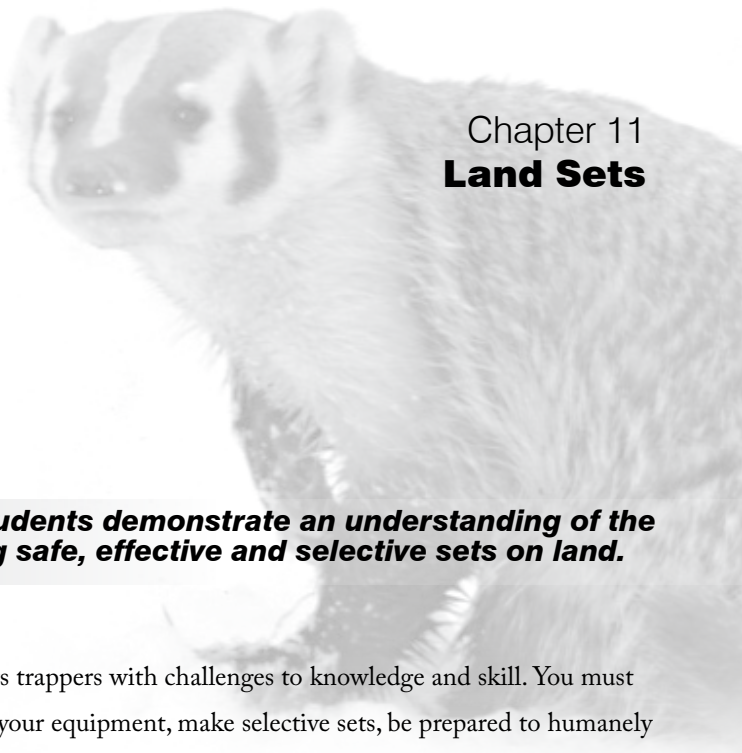

Good places for land sets:



Brush rows and
fence rows.

Ohio DOW



Brush-filled gullies and
drainages.

Ohio DOW



Near farm lanes that
intersect changing cover.

Ohio DOW

Use selective techniques to avoid
pets. If you do catch a dog or cat,
release it and notify the owner.

Content Standard – Students demonstrate an understanding of the procedures for making safe, effective and selective sets on land.

Introduction

Trapping on dry land presents trappers with challenges to knowledge and skill. You must know how to properly prepare your equipment, make selective sets, be prepared to humanely dispatch live animals, and know how to release nontarget animals.

The dirt-hole set, flat set, post set, and cubby set are commonly used for coyotes, red and gray foxes, raccoons, skunks, opossums and other furbearers.

Know that land trap locations influence animal welfare and the selectivity of trap sets.

Avoid setting traps near homes or places heavily used by people and their pets. Trappers should choose set locations that:

- Minimize exposure to domestic animals and human activities.
- Prevent entanglement with fences or other objects that might result in injury.
- Are selective to capture furbearers.
- Avoid trails used by people.

Explain the benefits of using traps that meet Best Management Practice specifications for land sets

Trappers, biologists, veterinarians and researchers have studied many traps. BMP-recommended traps have been tested for:

- Animal welfare.
- Efficient ability to capture and hold animals.
- Selectivity for furbearers.
- Practical use in the field.
- Trapper safety concerns.

Identify four good places to make land sets

Good places for land sets include:

- Brush rows and fence rows that guide animal movements and provide rodents, birds, or other food for furbearers.
- Brush-filled gullies that provide food and shelter.
- Areas near farm lanes that intersect changing cover types, pass through brush rows, or provide gateways to other fields.
- Saddles or draws between terrain features or areas where predators can observe prey or watch for danger.

Explain or demonstrate the proper use of stakes, cross-stakes, cable stakes, drags, and grapples for anchoring traps on land

Trappers must know how to anchor their traps properly to hold furbearers and prevent injury. Incorporate swivels, shock springs, and appropriate chain length to reduce the potential for injury. Traps normally are anchored with stakes, but sometimes drags or grapples are used.

Steel stakes are recommended. Stakes must be long enough to hold the largest animal that may be caught. Under most conditions they should be 18-24 inches in length. Even longer stakes are needed in sandy soils. For foxes and coyotes a more secure method is required to prevent the animal from pulling it out. You may need to use a double-stake swivel with the cross-staking method for a better hold. Cable stakes are another choice, but cable stakes take more time to dig out when you remove your set.

In some terrain you may need to use drags or grapples. Drags and grapples allow animals to find cover nearby.

Shock springs are used on trap chains to help hold animals and prevent injuries. Use high quality shock springs of sufficient strength for animals you are trapping.

Swivels are important parts of your anchoring systems. Stake swivels and two or more chain swivels allow an animal to move freely without twisting the chain down to a point where it is easy for the animal to pull out of the trap or injure itself.

Demonstrate the proper method for bedding a foothold trap at a land set

Traps must be properly bedded for land sets to work. Traps should be set level or slightly below the level of the soil around it. The steps for bedding a trap are:



Use steel stakes on land.

Ohio DOW



Cross-stake.

Ohio DOW



Cross-stake fasteners.

Ohio DOW

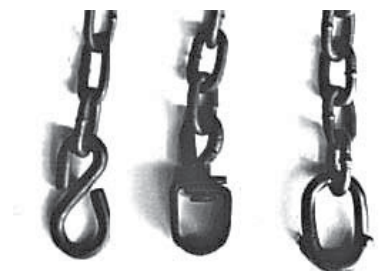

Stake swivels/ fasteners.

Ohio DOW

1



2



3



4



5



6



7



8



9



Joe Goodman

1. Dig a hole slightly larger than the outside profile of the trap. The depth will depend on the amount of chain you need to conceal under the trap – the longer the chain, the deeper the hole. When the set is finished, the top of the trap should be covered by 1/8-1/2 inch of soil and the pan should sit slightly lower than the ground around it.
2. Test the hole to make sure your trap will fit and make adjustments if needed. Position and drive your stake at the front of the hole (the side nearest you) where the loose jaw of the trap can rest on it.
3. Place the trap chain in the trap bed, cover it with soil and pack it with your hand or fist.
4. Place the trap in the trap bed with the loose jaw resting level on the top of the stake. Twist the trap slightly from side to side to settle it in the dirt.
5. Pack dirt tightly around the outside of the trap except for over the spring levers.
6. Use your finger to apply pressure to each jaw and spring lever (one at a time). If you detect movement, add some soil or a small dirt clod under the low spot.
7. Put the cover over the pan (if used). Sift dirt over the trap until it's nearly level with the surrounding area.
8. Locate the pan by brushing away some of the dirt. When you know where it is, pack dirt around the outside of the pan using the back of your hand.
9. If needed, brush or sift a fine layer of dirt over the set to blend it in with the surroundings.

The four-point system check includes:

1. Press on the loose jaw.
2. Press on the other jaw.
3. Press on a lever.
4. Press on the other lever.

If the trap is wobbly at any point, pack more dirt under that area and repeat the four-point check.



Demonstrate the proper method for covering a foothold trap set on land

Generally, foothold traps set on land must be covered to hide them from furbearers. Dirt, leaves and grass can be used to cover your traps. The covering must not interfere with the action of the trap.

Leaves and grass will work when you set a trap for raccoons or opossums, which are not as wary as foxes or coyotes.

Make sure nothing gets under the trap pan, or the trap may not work. Likewise, make sure there are no objects above the jaws that might keep the trap from closing properly.

Crumple up a piece of wax paper and unfold it for a trap cover. Crumpling wax paper softens it so it won't make noise when the animal steps on it. Using a small amount of fiberglass insulation between the underside of the trap pan and the baseplate also serves the same purpose as a pan cover.

Use a dirt sifter to remove small sticks and stones from the dirt used to cover your trap.

Explain or demonstrate the procedures for making three common land sets and name the furbearers that can be captured in them

Three sets every land trapper should know are:

1. Dirt-hole set.
2. Flat set.
3. Cubby set.

A scent post set is a variation of a flat set.

Dirt-hole set

The dirt-hole set is popular with fox and coyote trappers, and this type of set also attracts other furbearers. To make a dirt-hole set:

- Select a clump of grass or other natural feature for a backing at your set.
- Dig a small hole, about the diameter of a coffee cup, that slants back about 8 inches deep under the backing and put the dirt in your sifter.
- Dig a bed for your coil-spring trap in front of the hole so the trap center will be about 7 inches from the hole for foxes or 12 inches for coyotes.
- Stake the trap down and bed as described previously.
- Put a cover over the pan and sift the dirt on top.



Badger. Brent Ternes

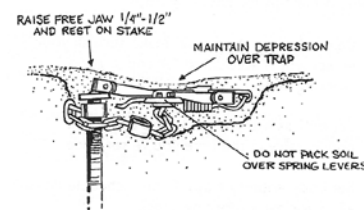

Bedded trap. Illinois Department of Natural Resources



A pair of pocket gophers. Marty Beard
Off-season trapping of nuisance species can improve your skills.



Step down set.

Illinois Department
of Natural Resources

The hole by itself will attract a fox or coyote, but many trappers place bait in the hole. If you use bait, cover it with some light vegetation. A furbearer will smell it, but the grass will prevent birds of prey from seeing it and landing at your set.

You can apply lure to the back edge of the hole and put some fox or coyote urine on the backing using a squirt bottle. Make certain you do not get any bait, lures or urine on the trap bed.

Step-down set

This set is a variation of the dirt hole set. Setting the trap in a shallow trench that extends in front of the dirt hole helps direct the animal's approach so it steps squarely on the trap pan.

Flat set

A flat set is most effective for foxes and coyotes, but it too attracts other furbearers. The flat set is similar to a dirt-hole set, but no bait hole is dug. Instead, an attractor such as an old chunk of wood is used to get the furbearer's attention. To make a flat set:

- Place the attractor where a furbearer will see it.
- Dig a bed about 6 inches in front of the attractor.
- Stake the trap, bed it, and sift dirt over it.
- Put a few drops of lure or a squirt of urine on the attractor.

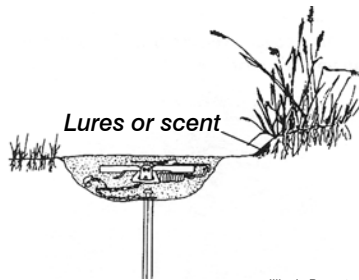

Flat set.

Illinois Department
of Natural Resources

Post set

A post set is made the same as a flat set, except that a broom-handle sized stick is used instead of an attractor. The post should be about 8 inches tall. Use lures or urine on the side of the post nearest the trap.

Walk-through set

This is a variation of a flat set and is useful when making the set again after a capture has been made. Loose dirt and vegetation that is saturated with animal odors is used to guide the animal's approach.

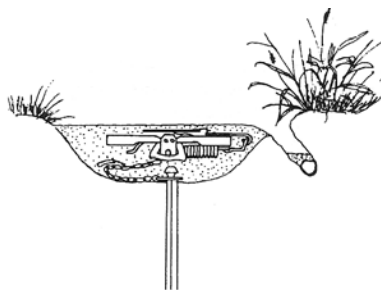

Dirt hole set.

Illinois Department
of Natural Resources

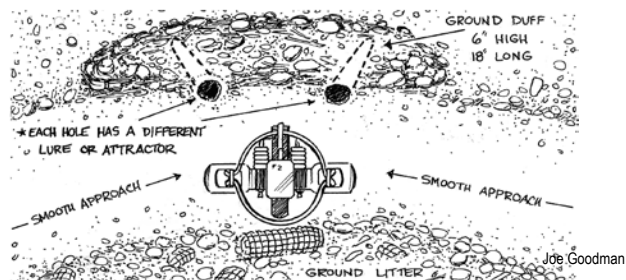

Cubby set

The cubby set on land is made the same way as a cubby set for water trapping. Cubby sets are used for raccoons, opossums, bobcats and other less wary furbearers. Cubby sets generally are not used for foxes or coyotes. To make a cubby set:

- Build a cubby and make certain the back is secure so the furbearer will enter from the front.
- Dig a bed for a coil-spring trap at the opening.
- Bed the trap and cover it as previously described.
- Place appropriate lures or bait in the back of the cubby.

Additional land set information

Enclosed foothold traps

Several types of enclosed foothold traps are available for raccoon trappers. These traps are highly selective for raccoons because of their design and the feeding characteristics of raccoons. Enclosed foothold traps are anchored and placed in the ground with baits attractive to raccoons, such as marshmallows, jam, honey, and anise. The bait is placed in the bottom of the trap, below the trigger. Larger animals cannot get their paw through the smaller opening and smaller animals cannot reach the trigger. Additionally, the trigger is activated by pulling rather than pushing. When the raccoon attempts to remove the bait from the device, the trigger releases a small spring arm that keeps the foot within the device.

Procedures for setting and using enclosed foothold traps vary. Some require disassembly and special tools. Some do not need to be placed in the ground. Enclosed foothold traps made of metal may be dyed to help conceal them and reduce the chance of theft. Some trappers prefer to leave them shiny as a visual attractant for raccoons.

Body-gripping traps

The use of body-gripping traps on land is highly regulated. Even when legal, body-grip traps should be used with care to prevent the capture of pets or nontarget wildlife.

Body-gripping traps can be enclosed in boxes to prevent nontarget animals from getting caught. Check the regulations for your state to see if this method is legal where you live. The size of the box, size of the opening and placement of the box make this a selective method of trapping.



Mink skull.

Brent Ternes



Beaver skull.

Brent Ternes



Mountain lion skull.

Brent Ternes

Enclosed foothold traps are selective for raccoons and opossums.

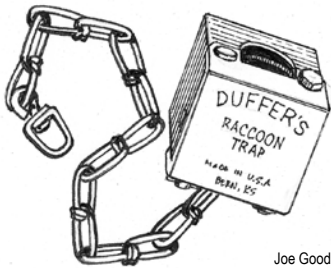

Joe Goodman

Duffer's™ trap.

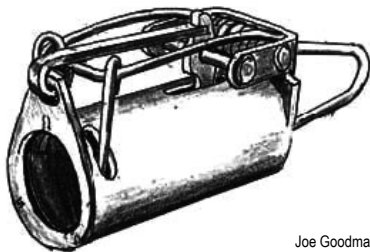

Joe Goodman

Lil' Griz™ trap.

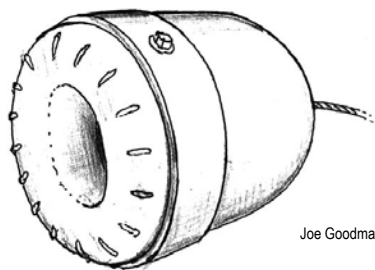

Joe Goodman

EGG™ trap.

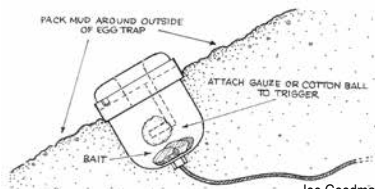

Joe Goodman



Silvertip Productions

Duffer's™ trap and EGG™ trap.



Silvertip Productions

Duffer's™ trap set in ground.



Silvertip Productions

EGG™ trap set in ground.



Joe Goodman

Low bank set for raccoon.

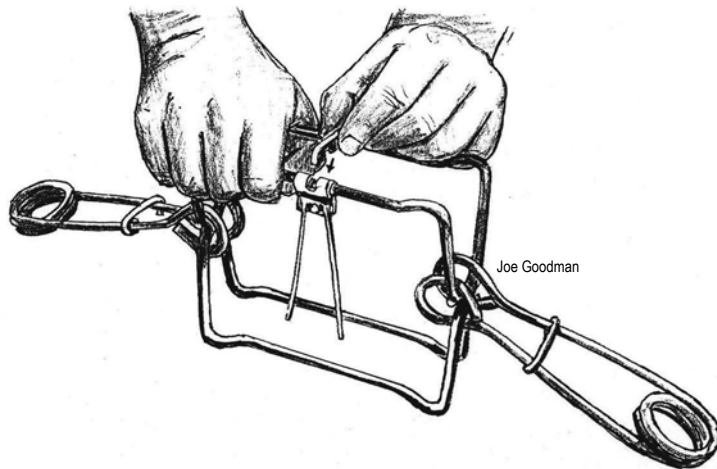

This is a view of a body-gripping trap box. Note the slots for the trap springs, and the wire hanging from the top. The back is covered with wood or wire mesh to keep the animal from reaching the bait without going into the trap.

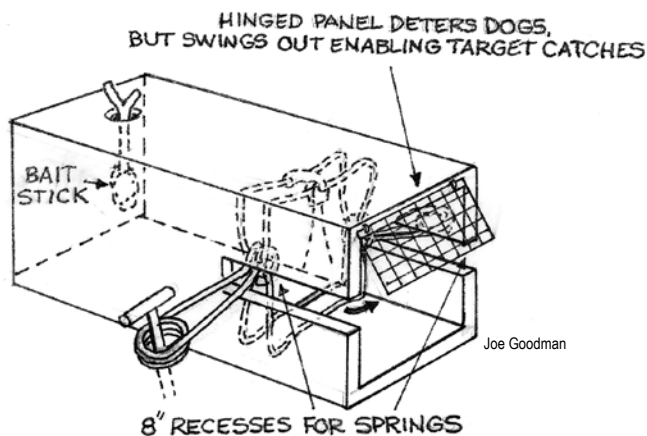

Some trappers set box traps on logs. Do not use this set in a location where dogs or cats will find the trap. Use sweet baits for raccoons. Raccoons often walk on top of logs.

Trappers have developed several methods for setting body-gripping traps in plastic buckets to prevent nontarget catches. Cut slots in the sides for the trap springs. Suspend sweet baits inside the bucket.

Check with your state or wildlife agency for details on safe, legal, and effective bucket sets that can be used in your area.

Practice safety when setting body-gripping traps – use setting tongs, safety latches, and a safety gripper.

Use sweet baits for raccoons to avoid nontarget animals

- Marshmallows.
- Anise.
- Honey.
- Hard candy.
- Jam.

Wooden boxes can be painted or allowed to weather so they blend in.

Some trappers camouflage their bucket while others prefer to leave them white as a visual attractant.

Using body-gripping traps on land



Medium size body-gripping trap for raccoons.



Leaning pole set.

Silvertip Productions



Leaning pole set.

Silvertip Productions

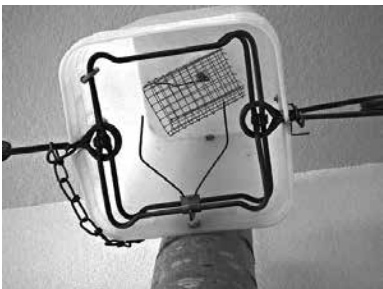

**Bottom view of
square bucket.**

Silvertip Productions

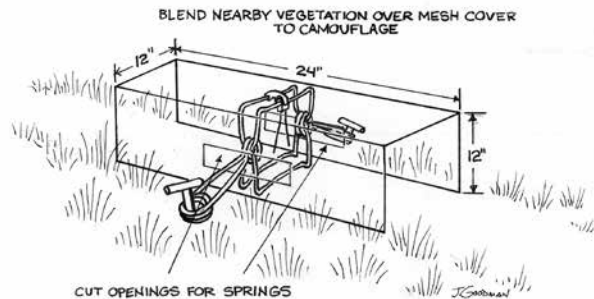
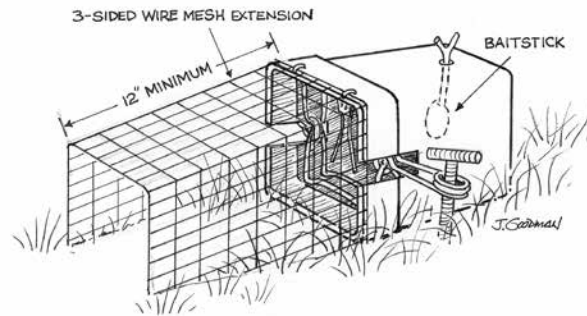
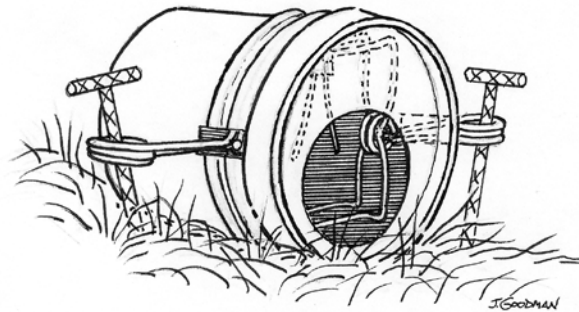

Leaning pole sets are used for American martens and fishers. A #120 body-gripping trap can be enclosed in a box, or set directly on the pole for martens. Use meat, fish, or strawberry jam for bait, and skunk essence for lure.

For fishers, use #160-#220 body-gripping traps baited with raccoon or porcupine meat. Use fisher musk, fisher urine, beaver castor or skunk essence for fisher lure. Make running pole sets under evergreen limbs to help keep snow from covering the traps.

Chapter 11 – Land Sets

Content Standard - Students demonstrate an understanding of the procedures for making safe, effective, and selective sets on land.

Know that land trap locations influence animal welfare and the selectivity of trap sets.

- Trappers should set their land traps at locations that:
Minimize exposure to _____ and _____ activities.
Prevent entanglement with _____ or other objects that might result in _____.
Are _____ to capture furbearers.
Avoid _____ used by _____.

Explain the benefits of using traps that meet Best Management Practice specifications for land sets.

- BMP traps have been tested for:
Animal _____.
Efficient ability to _____ animals.
Selectivity for _____.
Practical _____.
_____ safety concerns.

Identify four good places to make land sets.

1. _____
 2. _____
 3. _____
 4. _____
- Good places for land sets include:
_____ rows and _____ rows.
_____ gullies.
Near farm _____ that intersect changing _____.

Explain or demonstrate the proper use of stakes, cross-stakes, cable stakes, drags, and grapples for anchoring traps on land.

- Be prepared to explain or demonstrate the proper ways to anchor your traps.

Demonstrate the proper method for bedding a foothold trap at a land set.

- Be prepared to demonstrate the proper method for bedding a foothold trap at a land set.

Demonstrate the proper method for covering a foothold trap set on land.

- Be prepared to demonstrate the proper method for covering a foothold trap at a land set.

Explain or demonstrate the procedures for making three common land sets and name the furbearers that can be captured in them.

- Be prepared to demonstrate or explain the procedures for making three common land sets and name furbearers found in your area that can be captured in them.

Chapter 12

Cable Devices

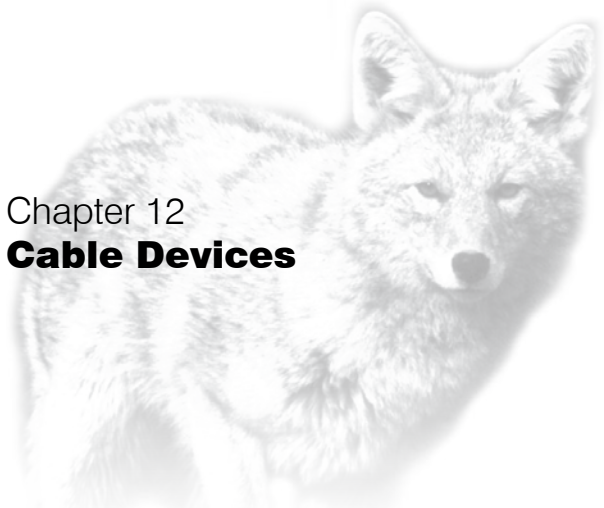

Content Standard – Students demonstrate an understanding of cable devices and responsible techniques for using them.

Introduction

Responsible trappers can use cable devices to make selective sets for many furbearers. Animals often travel the same trails and paths on a regular basis. Locations where the trail narrows are good places to set cable devices. Place cable devices correctly in the center of the line of travel, so the targeted furbearer will walk into it. Furbearers are accustomed to walking through weeds and brush, so cable devices do not alarm them.

Identify cable device equipment and materials

- A. Nonmechanical Lock
- B. Side Profile of Nonmechanical Lock
- C. J-Hook Breakaway Device
- D. End Ferrule
- E. Stabilizer Tube
- F. Maximum Loop Stop
- G. Inline Swivel
- H. End Swivel
- I. Trap Tag
- J. Deer Stop

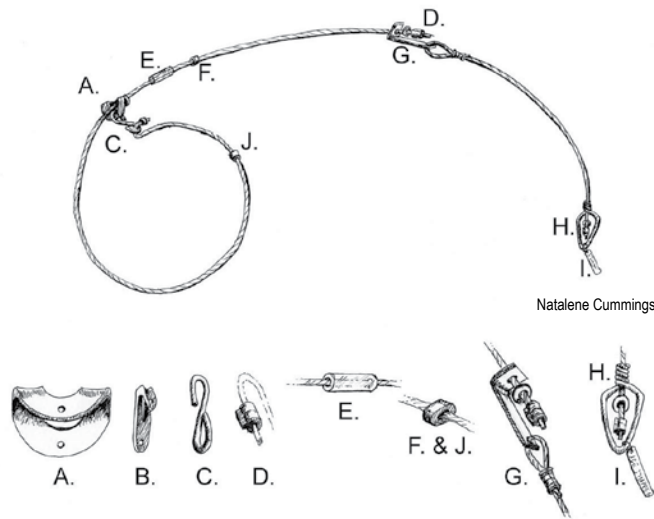

Joe Goodman
Cable device with Amberg lock.



Joe Goodman
Cable device with S-hook break-away device.

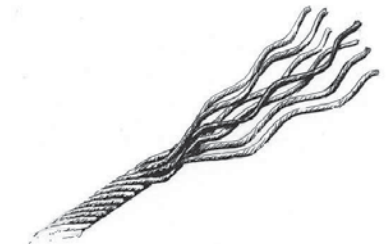

Natalene Cummings
Multi-strand steel cable – used in modern cable devices.

Cable devices

Modern cable devices have the same basic components: cable, an attachment for anchoring, a support cable, a stop, a lock, and release device.

Nonpowered cable device

A nonpowered cable device uses forward movement of an animal to place and close the loop on its body or neck.

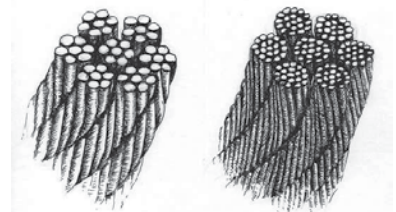

Natalene Cummings
7x7 Cable. 7x19 Cable.

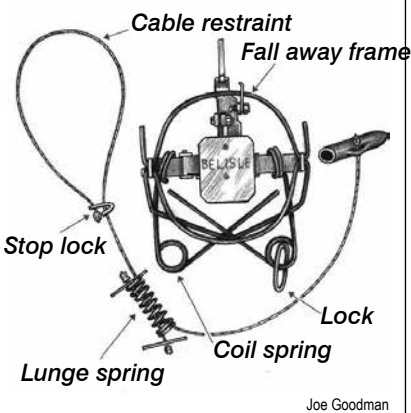
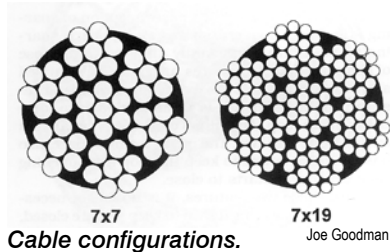

Unset spring-activated foothold cable device.

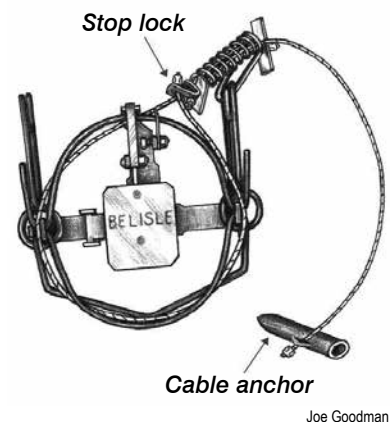

Coil-spring activated foothold cable device in the set position.

Powered cable device

The powered cable device uses a mechanical feature, such as a spring, to place or close the loop of the cable on an animal's neck or body. An example of a powered cable device is the coil-spring activated Belisle™ Cable Device, which uses a foothold-like pan system to activate springs that place a cable around the captured animal's foot.

Cable

Galvanized or stainless steel cable is the backbone of the device. Cable sizes used vary from 1/16th-1/8th inch and are constructed of several smaller wires wrapped together.

The three types of cable are wrapped wires configured as 7x7; 7x19; or 1x19. Cable configured as 7x7 consists of seven strands of small diameter wire wound into a larger strand. Then, seven of these larger strands are wound together to make the finished cable. This cable is of medium weight, very durable, has a course finish, and is the most commonly used cable. Cable configured as 7x19 uses 19 small wires wound into a strand with seven of these strands making up the cable. This cable is light, supple, and has a smooth finish. Cable configured as 1x19 uses 19 strands wound tightly together to make the one. This cable is light, stiff, and has a smooth finish.

Support collar

A support collar is a small piece of coiled wire or plastic tube slightly larger in diameter than that of the cable. The support collar is slid on the cable during assembly. The snare support is 9 or 11 gauge wire and fits snugly into the collar on the cable. The snare support is stiff and strong allowing the device to be set at a certain height in the targeted animal's trail.

Relaxing lock

A relaxing lock will move in either direction on the cable. When an animal pulls against the device it tightens, drawing the loop smaller. If an animal does not pull against the device, it relaxes. Animals can be released unharmed from cable devices with relaxing locks set as restraining systems on land. Many types of relaxing locks are available. Some relaxing locks are made to break at a given strength, allowing larger animals such as livestock or deer to escape.

Nonrelaxing lock

A nonrelaxing lock keeps a cable from loosening after an animal is caught. This lock will allow the loop to become smaller with tension, but it will not relax when tension stops. Some nonrelaxing locks incorporate a spring to keep the lock tight against the cable and prevent any slippage. Slippage would allow the loop to loosen and fail to kill the animal as intended.

Breakaway devices

In some situations, trappers must use breakaway devices to allow livestock, deer, wolves, or other large mammals to escape. Breakaway devices can be a lock that is designed to break apart; “J” or “S” hooks used to attach the cable to the lock; or an aluminum ferrule (crimped with a special tool) attached to the end of the cable as it passes through the lock. All devices are designed and intended to release when a certain amount of pressure is applied. When this pressure is applied, the device loop disassembles and allows the animal to leave with no part of the device on its body.

Breakaway Devices

A. Breakaway Ferrule

B. Breakaway Hook

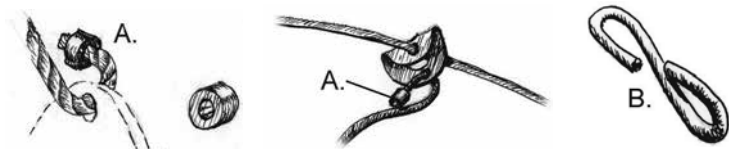

Natalene Cummings

Stops

Trapping regulations often require use of a “stop” to prevent a cable loop from closing below a certain diameter. Some trappers call them “deer” stops. Heavy gauge wire, steel nuts, or crimped ferrules can be used to make stops and maintain the cable loop at a minimum or maximum diameter, or both. The maximum loop stop prevents larger animals from entering the device. The minimum loop stop prevents the device from closing too tight. For example, if a deer steps in the cable loop the minimum loop stop keeps the cable from closing tight enough to hold it.

Swivels

Swivels are used in cable device anchoring systems to keep the animal from twisting and kinking the cable.

Cable/end ferrule

An end ferrule, also called a cable end, is crimped on the end of a cable to keep the strands from unraveling. Certain ferrules can also serve as a breakaway device.

Anchoring systems and attachment

The anchoring end of the device is opposite the loop. A slip noose is fashioned using a double ferrule and steel stop. The cable is passed through the ferrule and returned to pass through again. The steel stop is then crimped on the end of the cable. The loop is adjustable and works well for anchoring to steel stakes, tree trunks, fence posts, or other suitable anchor.



Cable/end ferrule.



Natalene Cummings



Joe Goodman

Closed loop for anchoring.

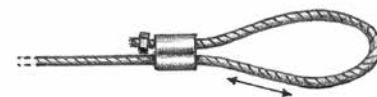

Joe Goodman

Slip noose for anchoring.



Joe Goodman

End swivel for anchoring.



Natalene Cummings

Double stake swivel.



Natalene Cummings

End swivel with box swivel.



Joe Goodman

Lazy "W" loop stabilizing wire.

A closed loop is made by passing the cable through a double ferrule and returning the cable into the ferrule, leaving a loop about 1 inch in diameter. The ferrule is crimped to retain the cable. A closed loop allows a single or double state swivel to be attached to the device.

A snare swivel is made with 9 or 11 gauge wire and constructed with a pass-through center. To assemble, pass the cable through the center of the swivel, a small washer is slid onto the cable, and an aluminum ferrule is crimped on the cable. The swivel allows the cable to turn freely while attached to the anchor.

Attachments, stakes and loops need to be strong enough to hold an animal that can pull against it using all four legs. A poorly anchored device will fail to hold a target species and will not allow a break-away system to function properly should a nontarget species be captured.

Support wire

A cable device requires support in order to be suspended in the animal's travelway. A variety of support systems exist for applications to water, dirt, or frozen ground. Supports need to be sturdy and stiff enough to handle water current or wind.

A cable device suspended in water can be supported by a piece of 11 gauge wire. A lazy "W" is fashioned on one end and the other wrapped around a solid stick, woody vegetation, or pushed into the bottom. The stem of the device is woven through the "W" to hold it in place. In areas with water current, fashion a "U" (instead of a "W") at the end of the wire and place the stem of the device in the "U." Use pliers to crimp the wire to the stem.

A cable device suspended over ground can be supported by a piece of 9 gauge wire. The wire is cut long enough to be bent back on itself about 6 inches from one end and extend up over the trail. The wire is bent and pushed into the ground, stabilizing the support wire. The upper end of the wire is inserted into the support collar on the device. In areas where trails pass through heavy shrubs, brush, or small trees, the support wire can be wrapped around the woody vegetation.

A cable device suspended over a frozen surface can be supported by a piece of 9 gauge wire attached to a metal stake or rod. The stake or rod is of sufficient strength to withstand hammering into the frozen surface. Railroad tie stakes, heavy landscape nails, rebar, or similar metal rods are used. The support wire is inserted through a hole in the stake or is welded in place. The support wire is of sufficient length to suspend the device over the trail and accommodate increasing snow depth as winter progresses.

Cable cutters

Use cable cutters to cut steel strand cable. It is nearly impossible to cut cable with pliers used for regular wire.

Device construction

A variety of tools and knowledge are required to construct cable devices. Quality parts and tools are purchased from reliable manufacturers or supply dealers. A working knowledge of cable behavior and device function is required.

For a cable device to perform efficiently and reliably, it must be constructed of good quality material and be assembled with care. The basic components of a device consist of cable, lock, release device, aluminum ferrule, stop, and metal identification tag (trapper's name, address, and telephone number). Special attention is given to ensure each component matches the diameter of the cable and appropriate cable strength to capture the animal.

During construction, lay the cut lengths of cable on a flat surface and make sure they lay flat and are not sprung or damaged.

The parts are assembled in a logical sequence on the cable until the device is complete. An example would be to cut the cable to length, use a swagger to crimp an aluminum ferrule, add a washer and snare swivel, add the metal identification tag, crimp a stop, thread the lock on the cable, and attach a release ferrule or hook to the lock.

Check the operation of the device after assembly. The lock should move down the cable smoothly and either lock on return or return smoothly (depending on system). A completed device will also lay flat on a horizontal surface.

Explain the procedure for treating cable devices

Treat cable devices prior to use for three reasons:

- To reduce light reflection and visibility.
- To remove undesirable odors.
- To add natural scent to the device so the animal does not become suspicious.

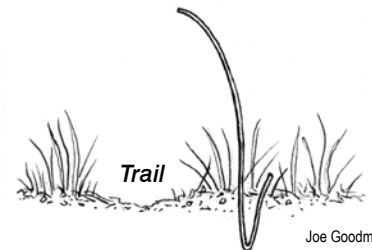

9 gauge loop support wire with unfrozen ground.

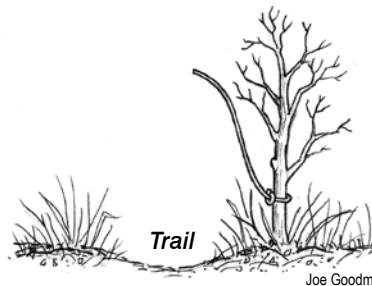

9 gauge loop support wire with frozen or unfrozen ground.

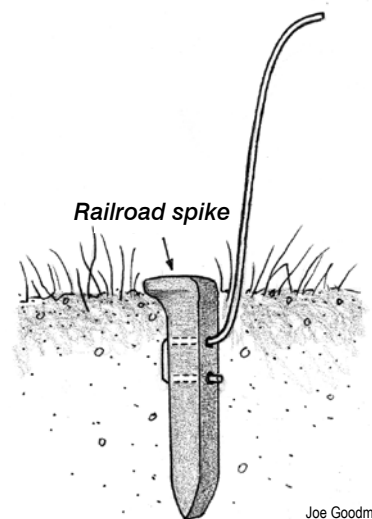

9 gauge loop support wire with frozen or unfrozen ground.



Natalene Cummings

Pack basket.

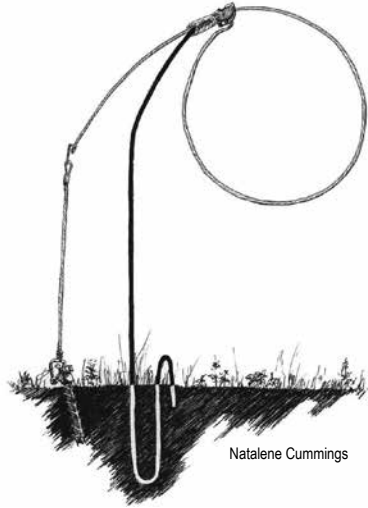

Natalene Cummings

Cable device in ground.

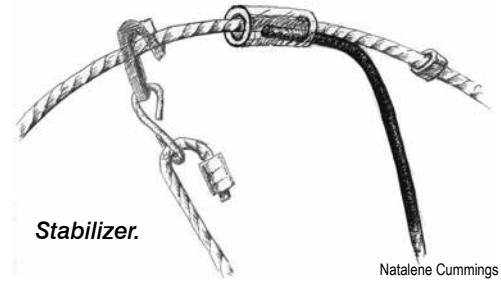

Stabilizer.

Natalene Cummings

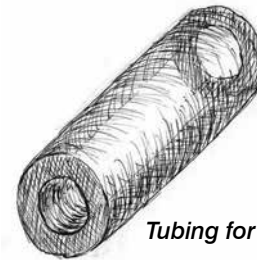

Tubing for stabilizer.

Natalene Cummings



Natalene Cummings

Coyote.

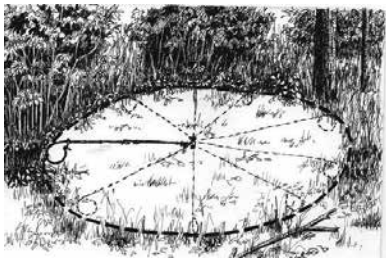

Natalene Cummings

Capture circle.

Treating cable

Cable devices are treated before being applied to the field. Treating removes any manufacturing oils or lubricants from the metal parts and cable; removes foreign odors from handling or contamination; and reduces light reflection from the device so it will be less visible to an animal.

Coil the devices to be treated and lay flat in a pan with sides. Manufacturing oils or lubricants from the metal parts and cable can be removed by mixing water with a concentrated soap solution. Cover the devices with this solution and boil for approximately ten minutes. Remove from heat, pour off the liquid, and then rinse the devices with clean water. Devices are then simmered for 20-30 minutes in a solution of baking soda and clean water (one cup of baking soda with two quarts of water). Cover the coiled devices with the baking soda and water solution and bring to a rapid boil. Reduce the temperature and simmer for the remaining time. Pour off the liquid when complete and allow the devices to air dry in an odor-free environment. Store the treated devices in a sealed container to prevent contamination. Note: treating devices in this fashion turns the cable a dull gray color and helps conceal the device in the field. If devices need to be colored, match the color to the surrounding vegetation.

Natural scent can be added to the devices by immersing them again in a solution containing bark, moss, plant leaves, or spruce needles collected from your trapping areas. This will darken the cable devices and add some natural scent.



Reusable components

A cable device becomes unusable once a capture is made. The captured animal exerts pressure on the cable and causes the cable to kink, bend or curve against the natural wrap of the cable strands. The cable will no longer lay flat or be able to hang in a natural loop. The lock and swivel may be reused if they are not damaged. Inspect each carefully to insure they will work properly in the future. Simply cut the cable, move the re-usable parts, and construct a device with new cable and ferrules.

Explain procedures for making selective sets using cable devices

Modern snaring employs the use of a cabled restraint to capture an unsuspecting animal during travel. The device is a component in a system intended to capture the targeted animal. The cabled restraint system is versatile and can be used to either restrain the captured animal alive or to kill it.

Live restraining systems incorporate a relaxing lock or lock stop and are set in nonentanglement situations. Conversely, intentional killing systems incorporate a nonrelaxing lock and usually entanglement.

For most targeted animals, it is the probability of entanglement at the set, rather than the lock, that determines whether or not the device will kill. Consider all possibilities in a given area when determining whether or not a killing system is a responsible capture method.

Using cable devices for aquatic furbearers

Cable devices can be set on land or in water. Trappers commonly use cable devices for beavers. Setting cable devices in water is one way to increase selectivity.

A careful trapper can make sets under ice using cable devices. The cables can be attached to stout poles and stuck in the mud to make channel sets or baited sets for beavers. During the winter, trappers can chop a hole in the ice and push poles through the hole into the mud with cable devices baited for beavers. The under ice beaver set is one of the rare times when bait is used with a cable device.

Cable devices also can be set as live-restraining traps in water and anchored on land. This will allow the furbearer to leave the water.

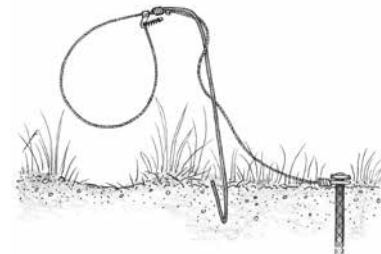

Blind trail set.

Joe Goodman



Chris Tischaefter

Equipment belt used with cable devices.

Tools include pistol, lineman's pliers, fencing pliers, and cable cutters.

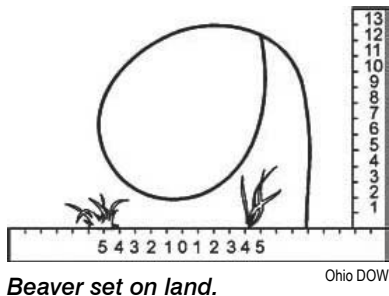

Beaver set on land.

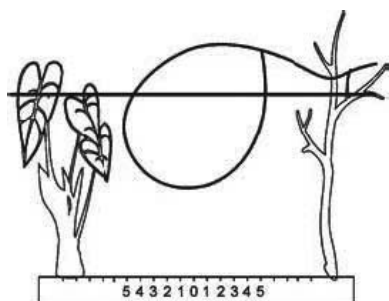

Beaver set in water.

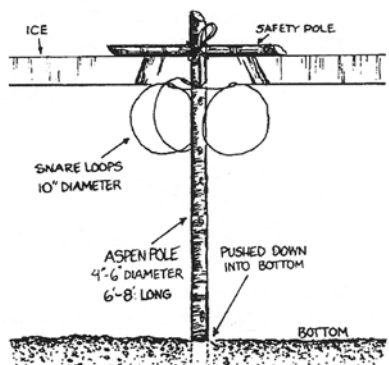

Under ice beaver set. Illinois Department of Natural Resources

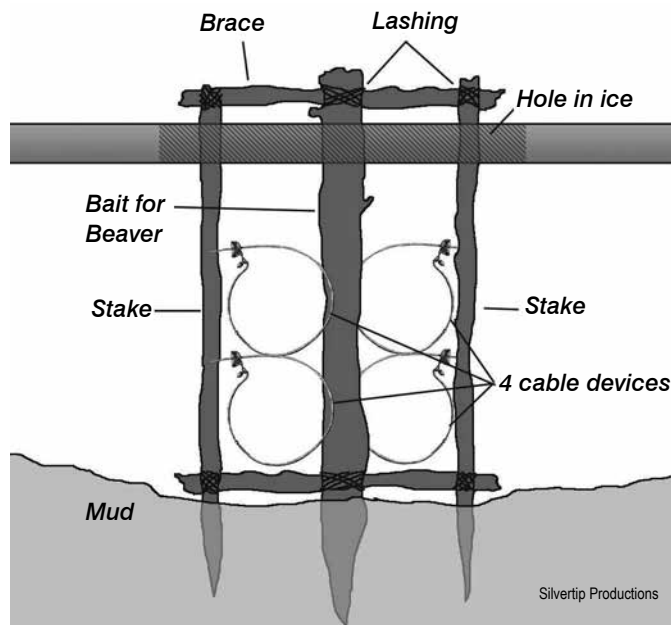

Using cable devices for furbearers on land

Set nonpowered cable devices to catch beavers around the body, as the head and neck are too short. Set nonpowered cable devices to catch foxes and coyotes around the neck. Foxes and coyotes have tapered heads that are wide behind the ears, so cable restraints around their necks will hold them well. Some powered cable devices are designed to place the cable loop on the animal's foot; others, when properly set, will place it around the neck.

Do not set cable devices on trails used by people, livestock, domestic animals or deer.

Cable devices work best in animal trails or blind sets where the animal will encounter it as it travels. Do not use bait or lure with nonpowered cable devices on land. Places where the path narrows are best. Center the cable loop in the path. The size of the loop and the height from the ground to the bottom of the loop will help you catch the animal you want and avoid other animals.

Loop sizes and heights

Loop size and height are critical to the animal's welfare and effectiveness and selectivity of the cable device. Cable device systems that kill require upper neck catches to provide a timely death. Conversely, a system with too large a loop or hung at the incorrect height may cause a body catch and not serve the animal well if designed as a killing device. On the other hand, cable devices can be used as restraining devices to hold species such as the beaver. In this case, a body catch is preferred.

The following list indicates general loop size and heights for various species. The loop size refers to the width and the height refers to the bottom of the loop above the packed surface directly below the loop (dirt, packed snow, or ice).

- Coyote cable loops (for live restraint) – Use a loop 10 -12 inches in diameter and the bottom of the loop is 10 – 12 inches from the ground.
- Coyote cable loops (for lethal sets) – Use a loop that is 9 – 10 inches in diameter and the bottom of the loop is 10 inches from the ground.
- Bobcat cable loops – Use a loop that is 8 inches in diameter and the bottom of the loop is 8 inches from the ground.
- Fox cable loops – Use a loop that is 6 – 8 inches in diameter and the bottom of the loop is 6 – 8 inches from the ground.
- Raccoon cable loops – Use a loop that is 4 - 6 inches in diameter and the bottom of the loop is 3 – 4 inches from the ground.
- Beaver cable loops on land – Use a loop that is 9 – 10 inches in diameter and the bottom of the loop is 2- 3 inches from the ground.
- Beaver cable loops in water (for swimming beaver) – Use a loop that is 9 -10 inches in diameter with one third of the loop above the water line.

Cable devices were legal to use in North Dakota until the late 1970s. It was at that time that cable devices were prohibited as a result of irresponsible behavior and illegal activity. During the 1980s, trappers worked with the legislature and together returned the privilege of using cable devices. The legislature directed the use of cable devices with the conditions that individuals use these systems with prescribed components and they be used responsibly. To do anything less will result in cable devices again being prohibited.

North Dakota is blessed to host to a variety of wildlife, some resident and some transient. As professionals, we must learn the landscape where we hunt and trap and know the types of animals we may encounter. The goal of setting cable devices is to catch the target species, and one of the primary considerations in doing so is to avoid incidental catches. Incidental catches of wolves, mountain lions, deer, turkeys, domestic animals and livestock can happen anywhere in North Dakota, and it is our responsibility to do everything within our power to reduce these occurrences.

We must be risk managers on our traplines. Knowing what animals may be present, knowing the appropriate capture systems to employ, and evaluating the risk associated with each must be an ongoing, daily process. Incorrect loop size or loop height, poor location, illegal equipment, or failing to check your sets in a timely manner will surely draw unneeded attention, and thereby increase the potential to again lose the privilege of using cable devices in North Dakota.



Natalene Cummings

Avoid setting cable devices in areas of high human or domestic animal activity.

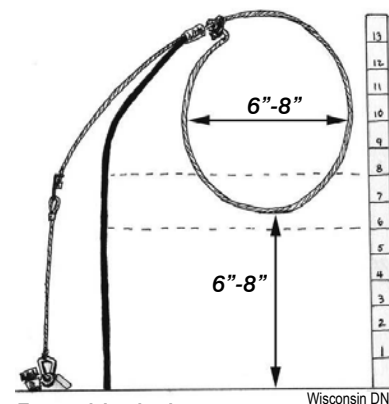

Fox cable device.

Wisconsin DNR

The potential for incidental catches will exist with every season. Your conduct in the field can reduce that potential and your preparation in advance can reduce stress if one should occur. Be prepared with the right equipment to release an unwanted catch, or have the contact information for the local North Dakota Game and Fish Department representative available for requesting assistance.

Set locations

Set locations vary for each species, and your knowledge of their travel ways will dictate where cable devices are placed. Scouting potential areas and identifying used trails in advance of the season will save valuable time. After several seasons of experience, set locations will be identified that can be used year after year. The habitat or topography surrounding these locations typically lends itself to a pattern of repeated traffic.

Cable devices are placed where animal activity is either observed or by encouraging animal activity with lure or bait. As examples, beavers are enticed through a device at a lured castor mound or baited set, or in a blind set in a runway. When using devices on land, foxes or coyotes commonly are captured in blind trail sets. Choke points in trails and crossovers are common locations. Deer or livestock carcasses also are used as draw stations to entice animal activity in a certain area. Animals frequently will visit draw stations in their territory and the trails lend themselves to set locations. Cable devices, like all capture devices, are required to be set a certain distance from exposed bait. This reduces the likelihood of catching nontarget animals.

Animals have the ability to adapt to a changing environment faster than people. Keep an open mind, be observant, adjust your methods accordingly and always consider the animal's welfare at each capture location.

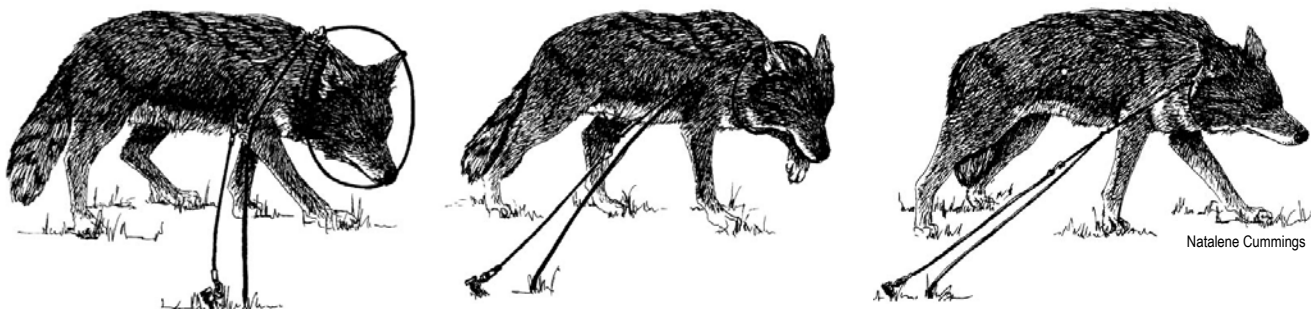

As an animal walks forward, the cable loop closes.

Chapter 12 – Cable Devices

Content Standard - Students demonstrate an understanding of cable devices and responsible techniques for using them.

Identify cable device equipment and materials.

- Match the labels below with their pictures.
 - A. Multi-strand steel cable
 - B. Nonpowered cable device, relaxing lock, and deer stop
 - C. Swivel and ferrule
 - D. Loop stabilizing wire

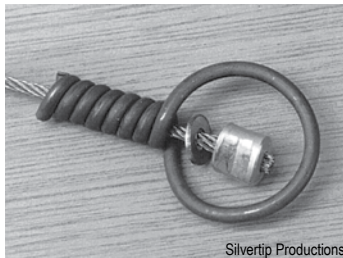
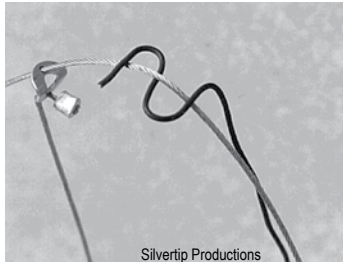
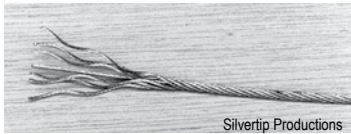

- Use your state trapping regulations to determine if cable devices are legal to use in your state. If so, describe legal restrictions on the types of cable devices you can use.

Legal? Yes No

Describe: _____

Explain the procedure for treating cable devices.

- Cable devices are treated before use for three reasons:
 1. Reduces _____ reflection and _____.
 2. Removes _____ odors.
 3. Adds natural _____ so the animal does not become suspicious.

Explain the procedures for making selective sets and using cable devices.

- Match the cable loop sizes and heights to the animal you want to catch.
 - A. Loops 6-8 inches, bottom 3-4 inches off ground _____ Coyote
 - B. Loops 6-8 inches, bottom 6-8 inches off ground _____ Beaver land set
 - C. Loops 10-12 inches, bottom 10-12 inches off ground _____ Fox
 - D. Loops 9-10 inches, bottom 2-3 inches off ground _____ Raccoon
- Cable devices set to catch an animal by the neck can _____ or _____.
- _____ and _____ design are the two factors that determine whether the set will be lethal or just restrain.

Chapter 13

Trapping Safety



Content Standard – Students demonstrate an understanding of potential risks to their personal health, safety and welfare from trapping activities.

Introduction

Trapping is not a dangerous activity, but there are risks related to weather, drowning, animal bites and disease. Develop safe attitudes. Make safe behavior a habit.

Describe the conditions that cause hypothermia, symptoms of its presence and treatment procedures

Hypothermia is a leading cause of death among people who enjoy outdoor recreation. Cold weather, wind and water can lead to a loss of body heat. When your body temperature starts to lower, hypothermia sets in.

Shivering is one of the first signs of hypothermia. When this happens, go to a warm place, put on warmer clothes, or build a fire. Soon after shivering starts, a person may become confused and clumsy. Watch for signs of hypothermia whenever you are outdoors in cooler weather. Even when air temperatures are in the 50s, hypothermia can occur.

Explain how to prevent hypothermia

Trappers can prevent hypothermia by wearing warm, dry clothing. Wool clothes are a good choice. Wool insulates even when wet.

When working in or near water, use hip boots (or waders) and gauntlets. If you get wet return to home or camp and put on dry clothes.

Recognize the symptoms of frostbite and treatment procedures

Frostbite occurs when ice crystals form in your body's cells. It is a common cold weather injury to people's cheeks, ears, nose, toes, and fingers. Frostbite symptoms include white to grayish yellow skin and an intense cold, numb feeling. Pain and blisters also may be present. Protect frostbitten skin from further injury. Drink warm fluids, put on more clothes, or wrap up in blankets. The frozen area can be soaked in warm water (102 to 105 degrees F). Never rub frostbitten skin as rubbing will cause further injury.



Develop safe habits around water and animals.

Silvertip Productions



Hypothermia is a leading cause of death among people who participate in outdoor activities.

Silvertip Productions

*Frostbite is a common injury.
Don't rub a frostbitten area.
Warm it gently.*



Trapper chopping thin ice with a hand ax. Silvertip Productions



Trapper has fallen through the ice. Chris Grondahl NDGFD

When walking on ice keep ice picks where you can reach them fast. If you fall through in deep water you will need the picks to pull yourself out to safety.

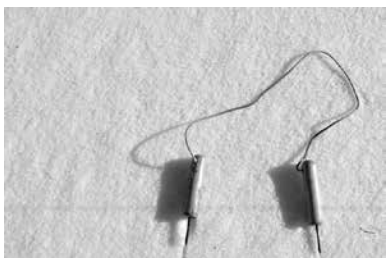

Ice safety picks. Chris Grondahl NDGFD

Recognize the danger of traveling on ice covered lakes, ponds, rivers, and streams

Avoid traveling on ice-covered streams and rivers. Water currents cause weak, dangerous ice. Ice on a pond or lake usually is more consistent, but be cautious. Springs, underwater structure, and other conditions can cause weak spots on lakes and ponds.

Newly formed clear ice generally is the strongest. The North Dakota Game and Fish Department recommends 4 inches of good ice to support a walking individual. Six inches or more of strong ice is recommended for multiple people, or snowmobiles.

White ice, or ice mixed with snow and slush, is weaker than clear ice. Candle ice, usually found in the early spring, forms when good ice starts to decompose. Candle ice may be unsafe, even if it is two feet thick. Ice cleats can help you maintain safe footing. Carry a walking staff to help you check for ice conditions in front of you as you travel.

Many trappers carry ice safety picks while working their trap lines. Ice safety picks have strong handles with short spikes in the ends. The handles are tied together with rope. Thread the rope and picks through the sleeves and back of your coat so you will have them handy if you fall through. It is difficult to pull yourself out of the water without ice picks.

If you do fall through the ice, try to climb out by facing the direction you came from when the ice gave way. When you get out, roll in the direction you came from when you fell through. The ice may be even weaker if you try to go a different direction.

If a companion falls through, lie down on the ice to distribute your weight. Reach out to the victim with a walking staff, or throw them a rope. If you approach too close you may fall in too.

After escaping from icy water build a fire immediately unless you are close to shelter or a vehicle where you can get warm. After falling into icy water, hypothermia will set in quickly. If you have a cell phone with you, call for help immediately.

Recognize dangers related to drowning while wading or trapping near water

Trappers need to be aware of the danger of drowning. It is easy to slip and fall down a steep bank, or slip into deep water holes of rivers and streams when wading. It is difficult to swim when wearing waders or hip boots or when your coat pockets are filled with heavy gear.



It is a good idea to wear an inflatable personal flotation vest when trapping around water. Good ones have a gas canister that can be used to inflate the vest instantly if you need it. The vest should also have a tube you can use to inflate it by mouth if the gas canister fails.

When wading, it is best to travel upstream because the water depth generally increases gradually. You are more likely to encounter steep drop-offs caused by currents when walking downstream.

Use a walking staff when wading to probe the water depth and bottom conditions. Smooth rocks or debris in the water can cause you to slip. You may encounter soft bottoms or hazardous conditions at points where two streams come together.

If you use a canoe or a boat for trapping follow all safety regulations. Take a boating safety education course available from the North Dakota Game and Fish Department.

Explain how to manage the risks for contracting diseases or parasites including rabies, West Nile virus, tularemia, Lyme disease, mange and trichinosis

Wild animals can carry a number of infectious diseases that can cause human illness. Some diseases are specific to one or a few species of furbearers, while other diseases affect many species of wildlife. Wildlife diseases transmittable to humans or domestic pets should be of concern to anyone who regularly encounters or handles wildlife.

Infectious diseases can be caused by numerous organisms and may spread by direct and/or indirect contact with infected animals. Trappers also can be exposed to parasites associated with wild animals. Follow the recommended precautions to protect yourself from potential hazards. If you become ill make certain your doctor is aware of your trapping activity.

General precautions include:

- Wear latex or other protective gloves, eye protection, and protective coveralls when handling carcasses or scat.
- Wash hands and arms thoroughly with soap and water after handling animals.
- Clean and disinfect knives, skinning boards, cutting surfaces and other equipment with a solution of one cup household bleach in one gallon of water.
- Avoid sick animals or animals that do not act normal.
- Do not drink untreated water from lakes or streams.
- Cook all wild game thoroughly.



Trapper wading in stream.

Silvertip Productions



Trapper with canoe.

Silvertip Productions

Rabies and tularemia are two of the diseases humans may get from furbearers.

PFD stands for Personal Flotation Device, an inexpensive item that can save your life!



Wear latex gloves. Silvertip Productions

Latex or Nitrile gloves provide a barrier for protection.



Raccoons can carry several diseases. Silvertip Productions



Mosquitoes may transmit the West Nile virus. Center for Disease Control

Animal diseases and parasites that may affect humans include:

Rabies – hydrophobia

Rabies is a virus that infects the central nervous system. Left untreated, rabies always is fatal. The rabies virus may be carried by all warm blooded mammals but it occurs most often among wildlife species such as raccoons, bats, skunks and foxes. Rabies usually is transmitted by the bite or scratch of an infected animal. Rabies also can be transmitted by contamination of a cut or scratch when skinning an infected animal, or from contact with your eyes, nose or mouth.

Rabies occurs in two forms in wildlife; “dumb” and “furious.” In the dumb form the animal is lethargic and may suffer paralysis. In the furious form the animal is restless, aggressive, and may bite at real or imaginary objects.

If you are bitten by a wild animal, wash the bite with soap and water, then seek medical attention. If possible, capture or kill the animal without damaging the head. Health authorities will test the brain tissue for rabies. Keep the animal refrigerated at 35-40 degrees F until it can be examined. Human Diploid Cell Vaccine (HDCV) can offer protection from the rabies virus without serious side effects. Ask your doctor for advice about HDCV, especially if you are trapping in areas where animals are known to carry rabies.

West Nile virus

Most people who are infected with the West Nile virus will not have any type of symptoms. About 20 percent of people who become infected will develop West Nile fever. Symptoms include fever, headache, tiredness and body aches. There may be a skin rash on the trunk of the body and swollen lymph glands.

The symptoms of severe infection (West Nile encephalitis or meningitis) include headache, high fever, neck stiffness, stupor, disorientation, coma, tremors, convulsions, muscle weakness, and paralysis. It is estimated that approximately 1 in 150 persons infected with the West Nile virus will develop a more severe form of disease. The incubation period is 3-14 days, and most West Nile fever symptoms last for a few days. Severe infection symptoms may last several weeks. Neurological symptoms or damage may be permanent.

It is best to prevent the West Nile virus by avoiding mosquito bites. Stay out of the field at dusk and dawn during mosquito season. Wear long sleeve shirts, long pants and socks when outdoors. Use a mosquito repellent containing DEET on exposed skin. The Center for Disease Control advises that you should not use DEET repellent on skin under your clothes. Do not apply repellents containing permethrin directly to your skin.



Tularemia – rabbit fever

Tularemia is a bacterial disease most commonly associated with rabbits and hares. Beavers and muskrats also may carry this disease.

Tularemia is most commonly transmitted to wild animals by the bite of blood-sucking ticks or fleas. The bacteria enter the body, multiply, and invade internal organs. The liver and spleen enlarge and become covered with white spots. Humans can get tularemia from skinning infected animals, drinking contaminated water, getting bitten by infected deer flies and ticks and sometimes by eating undercooked meat. Symptoms include fever, infected sores, swollen lymph nodes and flu-like feelings. These symptoms may become severe. With prompt antibiotic treatment, few cases of tularemia are fatal.

Lyme disease

Lyme disease is a bacterial infection spread by the bite of a deer tick (*Ixodes dammini*). When diagnosed early the disease can be treated with antibiotics.

People get Lyme disease when they are bitten by ticks carrying *Borrelia burgdorferi* bacteria. Ticks that carry Lyme disease are very small and can be hard to see. If these tiny ticks bite mice infected with Lyme disease and then bite people or other animals, the disease can be passed on. After several days or weeks the bacteria may spread throughout the body of an infected person.

Diagnosis is difficult since Lyme disease symptoms vary and are similar to other common illnesses. One of the first symptoms may be a red circular skin lesion, but often the rash will not appear. Other early symptoms are flu-like and may include weakness, headaches, nausea, fever, stiff neck, dizziness, muscle aches, sore throat and swollen glands. In advanced stages more serious symptoms may occur including facial paralysis, arthritis and heart problems. Consult your physician if you have symptoms of Lyme disease.

Prevent Lyme disease by preventing tick bites. Wear light colored clothing when walking in tick habitat. Wear long sleeves and long pants. Check yourself thoroughly for ticks. If bitten by a tick, remove it promptly and disinfect the bite with rubbing alcohol.

Leptospirosis

Leptospirosis is a bacterial disease that infects humans and animals. Almost all mammals can be infected, but it is more common in domestic animals than wildlife. The disease is known to infect striped skunks, raccoons, foxes, opossums, bobcats, muskrats and woodchucks. Leptospirosis spreads from eating infected food, contact with the urine of an infected animal or contact



Tularemia thumb lesion. Center for Disease Control



Cottontail rabbits may carry tularemia. FWS



Deer ticks may carry Lyme disease. Center for Disease Control

Ticks and fleas

Coyotes and other furbearers may have ticks and fleas that carry bubonic plague. The Center for Disease Control reports 10 to 15 cases of plague a year in rural parts of the western U.S. If you catch an animal with fleas in the western U.S., handle the animal with latex gloves. Put the animal in a plastic bag immediately, spray generously with insecticide, and tie the bag shut. This will kill most of the ticks and fleas before they leave the body when it starts to cool.



Beaver.

NPS Photo



Raccoon.

FWS

Do not risk your health or the health of others by handling sick or diseased animals. The value of the pelt is not worth the health risk.

with urine-contaminated water. The bacteria may enter the body through skin wounds, mucous membranes, or cuts. Leptospirosis bacteria multiply in the blood stream. It may affect the kidney and leave the body in the urine. Infection can cause flu-like symptoms in humans including headache, fever, muscle ache, vomiting and kidney damage. Antibiotics are very effective for treatment.

Rocky Mountain spotted fever

Spotted fever is a bacterial disease transmitted by ticks. Symptoms include a sudden onset of fever that lasts for 2-3 weeks, muscle pain, headaches, chills and weakness. A rash may develop on the hands, arms and legs and then spread to the rest of the body. Furbearers may carry the ticks that carry spotted fever. The disease occurs most often in the eastern half of the United States. Limiting exposure to ticks is the most effective way to reduce the likelihood of infection.

Sarcoptic mange

Mange is caused by a parasitic mite. It occurs throughout North America and is most commonly found among red foxes, coyotes, squirrels, raccoons and domestic dogs. Adult female mites burrow under the skin and deposit their eggs. This makes the animal scratch, chew or lick the infected area, which leads to inflammation and infection. When the eggs hatch the condition worsens. The animal's hair falls out. The skin thickens, gets crusted with scabs and cracks. Mange nearly always is fatal to red foxes and sometimes to coyotes. The mite is transmitted among animals through direct contact or by contact with contaminated areas such as dens or burrows. People can get the mites by handling mange-infested foxes, coyotes or domestic dogs.

Trichinosis

Trichinosis is caused by eating raw or under cooked pork and wild game infected with a roundworm parasite called *trichinella*. It affects people and many kinds of domestic and wild animals. The parasite forms cysts in muscle tissue.

Cook furbearer meat thoroughly until the juices run clear. Freezing game meat, even for long periods, may not kill all worms. Likewise, curing (salting), drying, smoking or microwaving meat does not consistently kill infective worms.

Giardiasis

Giardiasis is caused by a parasite that can be carried by many animals, including beavers. Beavers do not appear to be severely affected by the disease, but infected beavers can contaminate water sources used by people. Giardiasis spreads from drinking contaminated water or eating

contaminated food. Human symptoms include diarrhea, cramping, weakness and mild fever. The condition can last 1-2 weeks. Medication usually is prescribed to treat this ailment.

Raccoon roundworms

Baylisascaris procyonis is a common intestinal roundworm parasite found in raccoons and can cause a fatal nervous system disease in wild animals. The worms develop to maturity in the raccoon intestine, where they produce millions of eggs that are passed on with the feces. Released eggs take 2-4 weeks to become infective to other animals and humans. The eggs can survive for years.

Raccoons tend to defecate in specific places over a period of time. Likely places are at the base of trees, barn lofts, sand boxes, chimneys, attics or on high surfaces such as rocks or roofs. People become infected when they accidentally ingest the eggs. The eggs can become airborne as dust where people can inhale them. When humans eat or inhale raccoon roundworm eggs, they hatch into larvae in the person's intestine and travel through the body, affecting the organs and muscles. Severity depends on how many eggs are ingested and where in the body the larvae spread. Symptoms can include nausea, tiredness, loss of coordination and blindness. Infected animals may show signs similar to rabies.

Echinococcosis – (hydatid disease):

Echinococcosis is caused by infection with the larval stage of *Echinococcus multilocularis*, a microscopic tapeworm found in foxes, coyotes, dogs and cats. Infection causes parasitic tumors to develop in the liver, lungs, kidneys, spleen, nervous tissue or bone. The disease may be fatal. One form of the disease mainly affects wild animals including foxes and rodents. Wild foxes, coyotes and cats are infected when they eat *Echinococcus multilocularis* infected rodents such as field mice or voles. Dogs also can be a host. Cats are less likely to develop *Echinococcosis* than dogs, but also may become infected. Once the animal is infected, the tapeworm matures in its intestine where it lays eggs that are passed on in feces. The infectious tapeworm eggs are too tiny to see and will stick to anything.

People can get *Echinococcosis* by eating eggs in game meat or from contaminated food, water or soil. Surgery is the most common form of treatment. Medication may be required. Use latex gloves when skinning animals and disinfect your work areas to prevent this disease.

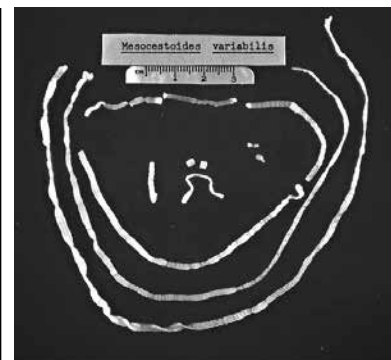

Tapeworms. Center for Disease Control



Coyote with mange and a healthy coyote. Jeremy Duckwitz

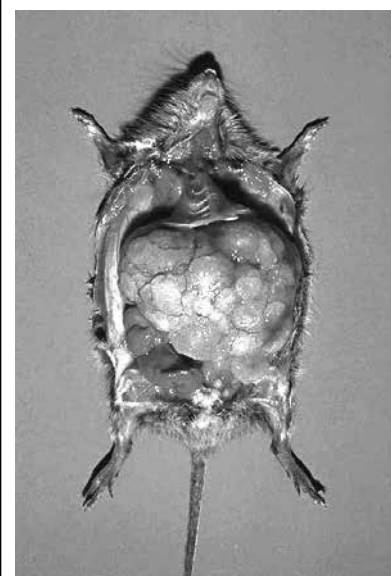

Cotton rat – died from echinococcosis. Center for Disease Control

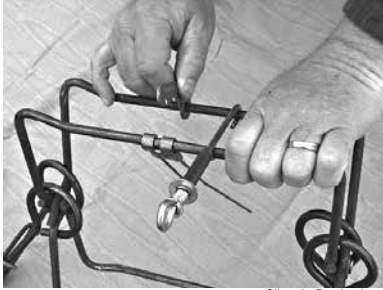

Silvertip Productions

Always use a safety gripper when setting large body-gripping traps.

Firearm Safety

- *Treat every gun as if it is loaded.*
- *Control muzzle direction. Be sure of your target and beyond.*
- *Keep barrel and action clear of obstructions.*
- *Unload firearms when not in use.*
- *Never point a firearm at anything you do not intend to shoot.*
- *Don't climb a fence or tree, or jump a ditch with a loaded gun.*
- *Never shoot at a flat, hard surface or water.*
- *Store firearms and ammunition separately.*
- *Avoid alcoholic beverages while hunting or trapping.*

Tapeworms and other parasites

People can get tapeworms and other parasites from contact with furbearer or dog feces. Keep your hands clean to prevent accidental ingestion of the microscopic eggs.

Other viral diseases

Pseudorabies, parvovirus, and distemper are diseases that can be carried by furbearers and passed on to pets or livestock. Have your pets vaccinated and seek treatment for them if you suspect these diseases.

Recognize and manage the risks for being bitten or injured by wild or domestic animals

Animal bites and scratches can cause serious injuries. Wash wounds thoroughly with soap and water, apply bandages and seek medical assistance. Keep the animal confined for observation if possible. If you can't confine the animal, kill it without damaging the head so that health authorities can test it for rabies.

See the chapter on "Running a Trap Line" for information on safe ways to release animals from traps to prevent bites and scratches.

Recognize the importance of making yourself visible to hunters

Trappers should make themselves visible to hunters. Wear hunter orange clothing, especially during hunting seasons where orange clothing may be required for hunters. Trappers occasionally have been wounded by hunters who did not see the trapper or failed to properly identify their background. Wearing blaze-orange clothing also will make it easier to find you if you are lost, injured or sick.

Recognize and manage the risks of setting large body-gripping traps for beavers

Some traps, such as large body-gripping traps used for beavers, can be dangerous to a trapper who doesn't know how to use them. If you accidentally are caught in a large trap you need to know how to release yourself, which may be difficult if you can't use one of your arms. Large body-gripping traps most often are set under water. You can drown or die from hypothermia if you get caught in a large trap set underwater.

When using large body-gripping traps, carry setting tongs and a length of rope with a loop in the end. Keep it in a pocket where you easily can reach it with one hand. If you are caught, thread the rope through the ends of the springs. Put your foot in the loop and use your free arm to pull the loose end. This releases the pressure on the springs so you can free yourself.



Describe the rules of firearm safety that apply to trapping

Many trappers carry firearms to shoot animals caught in traps. Take a hunter education course from the North Dakota Game and Fish Department to learn about firearm safety. Practice safe habits around firearms at all times.

When trapping it generally is a good idea to keep your firearm unloaded until you need to use it. It can be difficult to maintain control of a firearm when you are carrying gear and making sets.

When you shoot a firearm at an animal in a trap be careful about ricochets off the trap or rocks. If you are trapping with companions, everyone should stand behind the shooter.

Always look beyond your target when shooting a firearm and only shoot if it is safe. Keep the muzzle under control and pointed in a safe direction at all times, even when the gun is not loaded.

Know the importance of carrying a map and compass when trapping.

It is easy to get lost if you are in unfamiliar territory. When you are looking for sign and places to make sets you may not be paying close attention to landmarks and trails. Always carry a map of the place you are trapping and a compass. Many people carry a global positioning system (GPS) unit. If you carry a GPS, make certain you know how to use it. Carry a compass for a backup.

Explain important rules for survival including the use of a buddy system, the need to tell someone where you are going and when you plan to return, the value of a wireless phone, and the need to carry matches or firestarters

Although many people trap alone it is best to use a buddy system for any outdoor activity. That way if you are injured or sick, your buddy can assist you or go for help.

Always tell your family exactly where you are going and when you plan to return. If you change locations or plans, let your family know. Leave a map of your trap line at home.

Wireless phones are a good safety tool for trappers. Do not rely on the phone to get you out of all situations. You could be out of range or find yourself with a dead battery when you need your phone the most.



Silvertip Productions

Use the "buddy system." It could save your life!



Chris Tischaefter

Topographical map and compass.



Chris Tischaefter

Prepare for the worst – a field first aid and survival kit may make the difference.



Buckle up! Drive safe!

A trapper must know how to start a fire. Carry waterproof matches and firestarters with you at all times. If you find yourself in a hypothermia situation it may be difficult to start a fire without a firestarter.

Explain the importance of wearing a seatbelt when traveling to or from trapping areas

Trappers need to be careful when driving. Wear a seatbelt – it's the law. You may need to pull off the road in unusual places where other drivers are not expecting a car. Trappers develop a keen eye for observation, but you should not be intent on watching fields and other habitats when you are supposed to be watching the road.

Chapter 13 – Trapping Safety

Content Standard - Students demonstrate an understanding of potential risks to their personal health, safety, and welfare from trapping activities.

Describe the conditions that cause hypothermia, symptoms of its presence, and treatment procedures.

- List three signs of hypothermia:

1. _____

2. _____

3. _____

Explain how to prevent hypothermia.

- Trappers can prevent hypothermia by wearing _____ clothing.
- Use _____ boots or _____ waders, plus long-sleeved _____ gloves when trapping in water.

Recognize the symptoms of frostbite and treatment procedures.

- Symptoms of frostbite include:

- Describe the treatment procedure for frostbite:

Recognize the danger of traveling on ice covered lakes, ponds, rivers and streams.

1. Avoid traveling on ice-covered _____ and _____ where water currents can cause weak spots.
2. Carry a walking staff to help you check for _____ in front of you as you travel.
3. If you fall through the ice try to climb out by facing the direction you _____ when the ice gave way.
4. You should build a _____ immediately when you reach shore unless you are close to shelter or your vehicle.

Recognize dangers related to drowning while wading or trapping near water.

1. It is a good idea to wear an inflatable personal _____ when trapping around water.
2. When wading in streams, it is best to travel _____.
3. If you use a boat or canoe follow all _____ regulations and take a _____ safety course.

Explain how to manage the risks for contracting diseases or parasites including rabies, West Nile virus, tularemia, Lyme disease, mange and trichinosis.

- General trapping precautions to follow to protect against diseases include:
 1. Wear protective gloves, eye protection, and protective coveralls when handling _____ or scat.
 2. Wash _____ and _____ thoroughly with soap and water after handling animals.
 3. Clean and disinfect _____, _____ boards, _____ surfaces and other equipment with a solution of one cup household bleach in 1 gallon of water.
 4. Avoid _____ animals or ones that do not act _____.
 5. Do not _____ untreated water from lakes and streams.
 6. Cook all _____ thoroughly.

Recognize and manage the risks for being bitten or injured by wild or domestic animals.

1. If bitten by an animal you should wash wounds thoroughly with _____ and _____, apply bandages and seek _____.
2. Keep the animal confined if possible, or kill it without damaging the _____ so authorities can examine it for rabies.

Recognize the importance of making yourself visible to hunters.

- Trappers should make themselves visible to hunters by wearing hunter _____ clothing.

Recognize and manage the risks of setting large body-gripping traps for beavers.

- When setting large body-gripping traps, trappers should carry setting tongs and a length of _____ with a _____ in the end.

Describe the rules of firearm safety that apply to trapping.

1. When shooting at an animal in a trap be careful about _____ off the trap or rocks.
2. Always look beyond your _____ when shooting a firearm.
3. Keep the _____ under control and pointed in a safe direction.
4. Treat every gun as if it is _____.

Know the importance of carrying a map and compass when trapping.

- Be prepared to explain the importance of carrying a map and compass.

Explain important rules for survival including the use of a buddy system, the need to tell someone where you are going and when you plan to return, the value of a wireless phone and the need to carry matches or firestarters.

1. Always tell your family exactly _____ you are going and _____ you plan to return.
2. A trapper should know how to start a _____.

Explain the importance of wearing a seatbelt when traveling to or from trapping areas.

- Driving to and from hunting and trapping locations may be more _____ than the hunting or trapping activity. Always wear a _____ when driving.

Chapter 14

Running a Trap Line



Content Standard – Students demonstrate an understanding of the knowledge, skills, and attitudes needed to safely and responsibly harvest furbearing animals using Best Management Practices.

Introduction

Your success on the trap line begins long before the season opens. Trappers need to obtain written permission, scout properties and prepare equipment before the opening day.

Explain the importance of obtaining permission to trap on private land before the season opens

Early summer is a good time to ask farmers and other landowners for permission to trap. During the spring, farmers are busy planting crops. In the fall, they will be busy again, preparing for the harvest.

Dress neatly when you ask a landowner for permission to trap. Be polite, even if the landowner denies your request.

When talking to landowners, ask about possible problems with too many furbearers or neighbors who might want someone to trap their property. If you establish a reputation as a responsible trapper, you may find that landowners will call you and ask you to trap problem furbearers.

Contact landowners again shortly before the season opens. Ask about other people, such as hunters, who may be using the property. Let landowners know the days and times you will be on their property and the type of vehicle you plan to drive. Make sure they have your telephone number in case they need to reach you. Show the landowner the equipment you intend to use and how it operates.

Obtaining permission early will give you plenty of time for preseason scouting. When scouting or trapping, treat the property and the owner with respect.

Describe the advantages of preseason scouting

During preseason scouting trips find specific places to make your sets and plan the materials you need. Make notes of what you find and sketches of areas that look promising. This will allow you to set your traps out quickly when the season opens.



Don't wait until trapping season opens to ask for permission. Ohio DOW



Plat books help identify landowners and boundary lines. Chris Tischeafer



A tree girdled by a beaver. Brent Ternes

Check your state trapping or furbearer regulations for information on how often you are required to check your traps. Regardless of the law, responsible trappers will visit their traps routinely. Routine checks reduce the potential for injuries to the animal and will increase your success.

Why routine checks increase success

- *Less chance animals or traps will be stolen.*
- *If traps have been disturbed you can remake the set.*
- *Less chance for predation or spoilage.*
- *Less chance an animal will escape from a restraining device.*
- *Less chance an animal will injure itself or damage its pelt.*
- *If you remove an animal and set the trap again you may catch another one.*
- *Most furbearers are active at night (nocturnal), so check your traps as early in the day as possible.*



Preseason scouting leads to success.

Silvertip Productions

If you wait until the season opens to scout, it will be time-consuming and difficult to cover ground carrying your equipment. Scouting during the season may alert wary furbearers such as foxes and coyotes. Preseason planning allows you to make sets quickly and leave the area without creating much disturbance.

Make a commitment to check your traps

When you set out a trap line, you assume responsibilities. Animal welfare is a top priority. Most furbearers are nocturnal so it is best to check your live-restraining traps as early in the day as possible.

One important difference between trapping and hunting is your commitment to work your trap line until you remove your traps. Hunters can choose the days they want to hunt, but trappers must check their sets.

If you cannot personally fulfill your responsibility to wildlife and fellow trappers because of illness, have another licensed trapper check your line. If a licensed friend or family member knows where your sets are located they can check or remove your traps for you. Keep notes and sketches showing where to find your traps.

State three or more reasons to check your traps early in the day

There are many good reasons to check your traps as early in the day as possible:

- Animal welfare.
- Prevent escape from live-restraining traps.
- Release nontarget animals.
- Reduce chances of fur or trap theft.
- Reduce chances of predation on your catch.
- Lets landowners and others know you are responsible.
- Gives you time during the day or evening to skin or sell your fur.
- Gives you time to remake sets.

Animal welfare is the most important reason to check your traps as early in the day as possible.

Describe two ways to safely, quickly and humanely kill a furbearing animal

Nearly everyone agrees that animals should be killed as humanely as possible. However, their ideas about a particular method might be quite different. Some people believe that guidelines



developed by the American Veterinary Medical Association (AVMA) should be followed when killing wild animals in the field. We believe, as does the AVMA, that standards developed for veterinarians are not necessarily applicable or appropriate for activities like hunting and trapping. Licensed veterinarians can use lethal drugs that aren't available to the general public, they have more control over animals and don't need to worry about chemicals that make meat unfit for human consumption. While these limitations explain why methods used to kill animals on the trap line differ from those used to kill animals in a laboratory or clinic, you have the same obligation to kill animals as quickly and painlessly as possible – for their sake and yours.

The best way to kill a live raccoon, coyote, fox, bobcat or badger is with a well-placed shot with a .22 rimfire cartridge. Before firing, check for solid objects that may cause a ricochet. Anyone who comes with you should stand well behind you when the shot is fired. For a more complete overview of hunter safety, we suggest attending one of North Dakota's hunter education courses. Successful completion of this course is required for all first time hunters born after December 31, 1961.

If a skunk raises its tail before you can get close enough to shoot accurately, approach it slowly from upwind and talk in a soft, monotone voice. Aim for the heart (just behind the front leg between the elbow and shoulder). Avoid shooting the skunk in the head to reduce the risk of transmitting rabies. Skunks also tend to spray when shot in the head and direct contact with the spray can cause temporary blindness.

Using body gripping traps can reduce the need to kill the animal directly. However, these traps are effective only for capturing certain species of furbearers. Using submersion systems with foothold restraining systems in or near water also aids in killing the animal.

Trappers must plan the method of dispatch prior to setting traps. Planning reduces stress on you and the captured animal.

Describe two ways to release a nontarget animal from a foothold trap

Your personal safety is the top priority when you release an animal from a live-restraining trap. Your second priority is to release the animal without harming it. If you cannot do this on your own, get help.



Noosing a bobcat. Silvertip Productions

Releasing a large animal, such as a bobcat, is difficult.

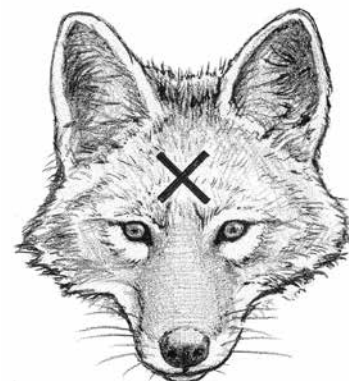

Joe Goodman

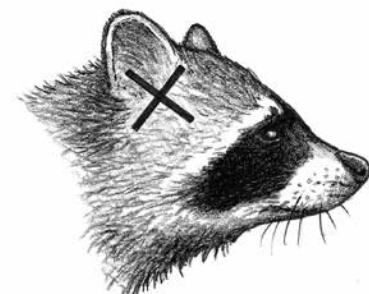

Joe Goodman

Our goal is to make a few good sets, not to make a lot of sets

Practice set construction before the season opens – practice makes perfect.



Rinse dirty animals in clean water.

Ohio DOW Productions

The first step in releasing an animal is to restrain it without hurting it. Trapping equipment dealers sell catchpoles for this purpose. To use it, slip the noose over the animal's head and pull it down snugly so the animal cannot escape. Use the pole to steer the animal's head away from the trap while you depress the levers or springs with your feet. When the animal's foot is free you can position yourself behind the animal and release the noose.

You should have no problems with birds of prey if you have properly covered flesh baits at your set. If by chance you do catch one of these birds, examine it closely for injury. If the bird is injured contact a wildlife officer for help getting it to a rehabilitator. If you can release the animal unharmed, you should cover it with a blanket or coat while you depress the springs on your trap. Be extremely careful. Birds of prey have strong talons and beaks that can cause serious injury. Once the foot is free, remove the covering and allow the bird to fly away.

Do not attempt land trapping if you cannot safely and humanely release nontarget animals.

Describe what to do if a domestic animal or a pet is caught in a foothold trap

If you catch a domestic animal, examine it for injury before releasing it. Although the animal may appear to be a pet, do not assume it will not bite. Carefully restrain any animal when you release it.

If a domestic animal is injured contact the owner or the landowner and make arrangements for medical care. No one wants to lose an animal or have it live with a permanent injury that could have been prevented with prompt treatment.

Compare the decision to make a few good sets for furbearers versus setting as many traps as possible

It is better to make a few good sets than to make many sets in a rush. Preseason scouting and planning will help you make sets that have a high chance of success. If you rush your sets, they may be of low quality and catch fewer furbearers. As you gain experience you can increase the number of traps you set.

Describe responsible fur handling procedures in the field and why it is important

Proper fur handling begins in the field. If an animal is wet and muddy, rinse it off in the cleanest water you can find. Remove the excess water by stroking the animal or gently shaking it. When you get the animal home, dry the fur as soon as possible.



When animals are trapped on land, keep them dry. Use a brush or comb to remove burrs or dirt.

Put any furbearers that are not bloody from shooting in a burlap bag or other protective cover. If an animal has fresh blood on its fur, lay it separately on newspaper or other material in the back of your truck or your car trunk. Be sure not to display animals in ways that may offend people who see them.

Care in the field shows respect for your harvest and it will make the skinning job go faster at home. Proper handling in the field improves the quality of the final product.

State three reasons a trapper should keep a daily journal

It is a good idea to keep a journal. Over time, it will help you increase your catch and bring back many good memories. Make notes about the types of traps you use, how you make your sets and how many animals you catch at a set before you remove it. Keep notes about different lures or baits you use. Soon your journal will help you know how to make your sets work the best during different parts of the season.

A journal also is also a good place to keep sketches and information about your sets. Remember, sketches will help someone else find your traps if you get sick or cannot run your line.

Three reasons to keep a journal

- *Increase your success.*
- *Guide others to your traps if you get sick.*
- *Save your memories to enjoy over the years.*

Responsible fur handling respects the life of the animal.

Proper fur handling begins in the field.

Chapter 14 – Running a Trap Line

Content Standard – Students demonstrate an understanding of the knowledge, skills, and attitudes needed to safely and responsibly harvest furbearing animals using Best Management Practices.

Explain the importance of obtaining permission to trap on private land before the season opens.

1. Early _____ is the best time to ask a farmer for permission to trap.
2. Obtaining permission early will give you plenty of time to _____ before trapping season opens.

Describe the advantages of preseason scouting.

- Preseason scouting trips allow you to find _____ places to set your traps and plan the _____ you will need to make your sets.

Make a commitment to check your traps.

1. Animal _____ is the top priority.
2. Most furbearers are nocturnal, so it is best to check your live-restraining traps as early _____ as possible.
3. Checking traps early in the day will mean there is less chance that _____ or _____ will be stolen.

State three or more reasons to check traps as early in the day as possible.

- List at least four reasons to check your traps as early in the day as possible:

1. _____
2. _____
3. _____
4. _____

Describe two methods to safely, quickly and humanely kill a furbearing animal caught in a live-restraining trap.

1. _____
2. _____

Describe two ways to release a nontarget animal from a foothold trap.

1. _____
2. _____

Describe what to do if a domestic animal or a pet is caught in a foothold trap.

- If you catch a domestic animal in a foothold trap examine it closely for _____ before you release it. If it is _____, contact the animal's _____ or the landowner where you trap so the animal can be treated.

Compare the decision to make a few good sets for furbearers versus setting as many traps as possible.

- Preseason scouting and planning will help you make sets that have a _____ chance of _____. If you rush your sets, they may be low quality and catch _____ furbearers.

Describe responsible fur handling procedures in the field and why it is important.

- In the space below describe proper fur handling procedures in the field.

State three reasons a trapper should keep a daily journal.

- Three reasons to keep a daily journal of your trapping activities include:
 1. Increase your _____.
 2. Guide others to your traps if you get _____.
 3. Save your _____ to enjoy over the years.

Content Standard – Students demonstrate an understanding of predator calling equipment and techniques.



Introduction

Predator calling is an outdoor activity as challenging as trapping. Knowledge of the animal and calling technique is essential for success. Predator calling is a harvest technique used in wildlife management and can be used successfully to target individual animals that may be doing damage.

Native Americans used their mouth to call wolves and coyotes, mimicking the canines' vocalizations, within bow or rifle range. Calls also were made by stretching a piece of sinew or grass between the thumbs and making whistles to attract coyotes.

One of the first references to modern calling and howling of coyotes is a report in the Journal of Mammology, dated May 1946 by J.R. Alcorn. From February 1944 to May 1945, Alcorn field-tested a squeak call, a howl call, and a distress call with excellent results in Nevada.

After World War II, predator calling quickly became a popular method of hunting predators. Early predator calls were marketed by Burnham Brothers, Johnny Stewart, Bud Lindsey, P.S. Olt, and Circe.

Many different predator calls have been developed since the days of sinew and grass, but many of the techniques remain the same. Calls have been designed to imitate everything from mice to



Harold Umber



fawn deer, but the most common calls produce sounds like that of a rabbit in distress. Predator calls vary from a simple “squeaker” to an elaborate electric remote control caller.

Explain the common species of furbearers that can be attracted using a predator call

An effective predator caller is knowledgeable about the predator and its prey. Understanding unique animal behavior and characteristics can lead to a successful experience.

Coyote

The key to the coyote’s success and survival lies in its ability to adapt to many situations, especially to the presence of humans.

Coyotes have keen senses to help them survive. Their sense of hearing is extremely sharp, and they can detect sound at great distances. Their sense of smell also is highly developed, both to detect danger and locate food. Although their eyesight is not as keen as hearing and smell, they can detect movements at considerable distances, and can pick out a shape that may be unfamiliar to them.

Coyote density in an area is related to the food supply. The more food that is available, the more coyotes the area can support and the smaller the size of each coyote’s territory. In areas with little food, coyote densities are lower and territories larger.

Behavior of both the adult and young-of-the-year is important to understand. After mating in late winter, both adults find and create a den site. The den site can be anything from a dense thicket of brush to a hole dug in the hillside. The male assists with the raising of the pups, which offers an excellent chance to the beginning hunter to learn more about coyote habits by finding a den site and observing their behavior from a distance.

In late winter and early spring, coyotes are very territorial. During this period, using a rabbit-in-distress call is not as effective as using a howler or mouth barks that sound like another dominant male coyote. Communication is an important activity among coyotes. Coyotes communicate through vocalizations (e.g. howls, barks, and yips) and through body posture. Similar behavior can be observed in domestic canines too. Young dogs will be submissive and crawl to an older dog, while adult dogs may approach each other stiff legged with teeth shown. The same is true of coyotes in the wild.



A lonesome howl.

Joe Goodman



*Red Desert coyote
howler.*

Chris Tischaefter



*Tube style coyote
howler.*

Chris Tischaefter



*A padded cushion
will make sitting
more comfortable.*

Chris Tischaefter



Red fox

As with the coyote, the key to red fox survival lies in the animal's ability to tolerate and exploit human presence.

Weighing only about 12 pounds, a red fox really is not much bigger than a housecat. Its thick, luxurious coat and long bushy tail give the illusion that the animal is much larger than it actually is.

Red foxes have acute senses that permit them to be an effective predator. Hearing and smelling are the fox's keenest senses. A red fox has the ability to detect a mouse squeak from great distances. Its sense of smell is adept at detecting prey, warning of danger, and interpreting scents left by another fox. The weakest fox sense is eyesight and the animals often cannot distinguish between objects that do not move. Foxes can, however, detect movement and seem able to know when stationary objects have been added to a scene.

In winter, red foxes can be observed curled up like a ball on a snow bank. The red fox takes short naps which are interrupted by periods of alertness. With its bushy tail covering its nose, the fox is able to tolerate even the coldest of North Dakota weather above ground.

Because a red fox typically maintains a rather small home range, it becomes familiar with its territory. Every fence row, woodpile, rabbit run, ravine and cornfield becomes very familiar to the predator. The fox knows, too, which escape routes to use when a dog or hunter is in pursuit.

Bobcat

Like foxes and coyotes, bobcats are opportunistic predators that feed upon a wide variety of animals, but specialize in hunting smaller-sized prey like cottontail rabbits.

Bobcats are secretive, shy, solitary and primarily nocturnal, and therefore are seldom seen in the wild. The bobcat's sense of smell is not as acute as that of foxes and coyotes, but their keen



eyesight and hearing makes them an efficient predator. These unique characteristics make calling a bobcat difficult and challenging. Rabbit-in-distress cries can be an effective call for bobcats, but because of their secretive nature, they typically are very cautious in their approach to a call.

Know the types of equipment used when predator calling.

Camouflage and clothing

To make the most out of your camouflage choices and your clothing purchases, you first must know “why” you are wearing camouflage clothing.

Camouflage is worn to hide yourself, to break up your outline and to blend in with the surroundings. Patterns of camouflage probably are not as important as color. In general, tan colors are best in the fall, green colors are the best in spring, and white camouflage is best in a snow covered landscape. In open country, lighter colors are better than darker colors.

The softness, warmth and comfort of the clothing are just as important as the pattern of clothing. The predator caller also wants clothing that protects from the wind. Because predator callers often lie down or sit for long periods of time, proper preparation is key to an enjoyable day. It’s best to dress in layers of clothing to maintain comfort during the hunt.

Field testing is the best way to determine what type of camouflage is best for an area. Simply take various types of camouflage and set it out in areas where you hunt and back off a hundred yards or so and look at it – if it sticks out and does not blend well, it likely will be noticed by a predator. However, compromises will have to be made because habitats are highly variable. Camouflage and colors that work well in one type of habitat may not work as well in another. Instead of buying clothing for all habitat types, find out what works best for most of your situations.

Sunlight will produce a glare when it shines on certain equipment. Camouflage and conceal items such as belt buckles, watches, binoculars, shooting sticks, firearms and eyeglasses.

Background is essential to concealment. Camouflage will not help if you silhouette yourself against the skyline. Proper camouflage blends into the background and you must position yourself where there is a background. Predators are color blind, and as long as the caller is concealed and remains still while the predator is within sight, the caller likely will be undetected.



Diaphragm predator calls.

Chris Tischaefel



Gloves and hand warmer.

Chris Tischaefel



Scoped rifle and bipod.

Joe Goodman

Always keep in mind that when a predator hears a call, it can pinpoint precisely where the call is coming from. As the predator approaches your location, it looks directly toward where the sound is coming from. Movement at that critical time likely will cause the predator to stay or leave the area.

Firearms

Rifle manufacturers, calibers, bullets, and load types vary. It is important to have a reliable, flat-shooting rifle that fits you well and is comfortable to shoot.

Good varmint calibers include the .223, .22-250, .220 Swift, .243, 6mm, and .25-06. These calibers have a flat trajectory out to 200 to 300 yards. Good marksmanship requires practice to optimize the performance of the shooter.

Rifle scopes are available in a variety of styles. The most commonly used scopes have variable magnification, typically 3-9, or 4-12 power.

The fixed-power scopes often are a bit less expensive than the variables, and also can be used to judge the range of the predator. Four or six power is the most common. A predator at a certain distance fills a certain part of the rifle scope, and with time and experience, knowing this can benefit the hunter in determining the approximate distance to the target.

Shotguns also are very effective for predator hunting, especially where vegetation is thick and the hunter has a limited range of view. Ten or 12 gauge shotguns are common gauges for predator hunting, typically loaded with BB or 4-buck shot. Some hunters prefer to carry both a shotgun and rifle to the calling stand.

Camouflage the gun with tape, cloth, or paint to remove the reflective finish. Gun manufacturers produce both shotguns and rifles with a factory camouflage finish.

Bipods and shooting sticks are available to help improve steadiness and accuracy when shooting. Make sure the size and length of the bipod or shooting sticks are properly adjusted for the hunter. Bipods and shooting sticks come in various sizes for sitting, kneeling or prone shooting.

List the types of calls used when predator calling

Predator calls are designed to imitate a variety of animal sounds, with the most common calls producing sounds of rabbits-in-distress. The most productive calls are those imitating prey species common to the area; however, different calls may initiate a curiosity response and also work well.



Knee belt rifle rest.

Chris Tischaefter

Predator calls are broken down into two major categories: 1) hand or mouth calls; and 2) mechanical or electronic calls.

Hand and mouth calls

Hand and mouth predator calls consist of a variety of different types of calls; including: closed-reed calls, diaphragm calls, open-reed calls, howlers and squeakers or coaxers. Closed-reed calls typically are tubular in shape and have a small internal aluminum reed mounted inside the tube. These calls work fine in warm weather, but can freeze up when moisture gets into them during cold weather. The closed-reed calls also are limited to whatever sound the call is designed to make. Sound pitch variation is made by increasing or decreasing the amount of air that is blown through the call.

Diaphragm calls are very effective for predator hunting due to their versatility and diversity of sound. The call consists of a small aluminum frame that holds a latex reed(s) with a tape-type covering. These calls come in a wide variety of styles and reed configurations, but the single reed call is the easiest to learn and usually will produce the best quality of sound. The entire call is placed against the roof of the mouth and held in place with the tongue. Air from the diaphragm is blown across the call causing the latex reed(s) to vibrate, making the sound.

Open-reed calls probably are the most common of the hand-held calls. These calls, tubular in shape, have a plastic reed located on the sloped mouthpiece. Open-reed calls allow the hunter to make a variety of sounds such as howling, rabbit-in-distress, canine-in-distress and rodent squeaks. These sounds are made by applying pressure against the plastic reed with the teeth or lips and moving along the sloped mouthpiece. Open-reed calls do not freeze up as easily as closed-reed calls in cold conditions.

Howlers are utilized to locate coyotes and attract them to your location. These calls generally consist of an open-reed call with a funnel-type attachment to enhance the sound and volume. There are many types of howlers, each producing a number of different howls, barks, yips and other coyote vocalizations.

The rodent squeaker or coaxer sounds similar to that of a child's squeeze toy. This call does not have much range but is extremely effective in "coaxing" predators to come closer or stop.

Mechanical or electronic callers

Some of the first electronic callers were record or cassette tape players with recorded sounds and powered by C or D-cell batteries. Although cassette operated electronic callers are still

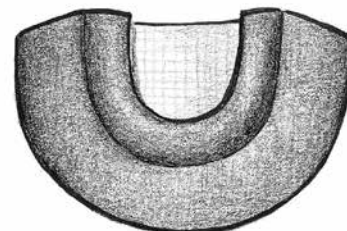

Diaphragm call.

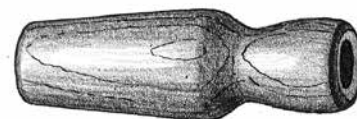

Closed reed call.

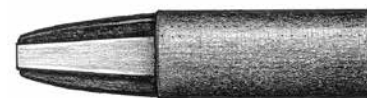

Open reed call.



Coyote howler.

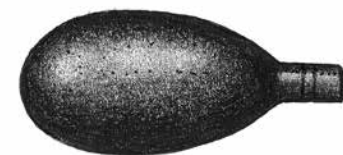

Rodent squeaker.

Illustrations by Joe Goodman



Chris Tischaefter

**Electronic predator caller
with remote control.**

available today, the newer calls use compact discs and digital sound. These newer callers also produce very little static or background noise and sound realistic.

The greatest advantages of electronic calls are realistic sounds and the capability to call with limited movement. The speaker should be placed in a good location and the volume adjusted properly. Disadvantages may be the price and the added weight.

Most predator callers have several different calls and practice with all of them. Situations differ and may warrant a certain type of call as well as particular sound and volume. Experimenting with different calls and situations can help improve predator calling skills.

Know that the techniques and strategies vary for each species and calling location.

Permission

It is a good practice to gain permission from landowners to hunt private land. Landowners see predators throughout the year and a conversation with them may provide valuable insight.

Scouting

Successful hunting for any species requires scouting, especially predator hunting. Most of the country in North Dakota is wide open, and trying to determine where to start hunting requires analyzing the land and finding the areas most likely to hold predators. Animals require water, food and cover. Hunters can apply those needs to the terrain and determine where to begin. Land ownership and topographic maps can be valuable tools during this scouting process.

Time

The best time to locate, spot and call predators is dawn and dusk. Depending on the type of day (calm versus windy) and the time of year (fall versus late winter), the ideal calling time may extend three to four hours after dawn.

During winter months, predators may be more visible during daylight hours because they may need to hunt for food all day long. As a result, predator callers may find they too may be successful all day long.

The setup

Caution should be used when approaching a potential calling location with your vehicle. If possible, drive into an area with the headlights off and park the vehicle a half-mile or more away from where you'll call from. Get out of the vehicle quietly, and begin your stalk from the time you leave the vehicle.



Chris Tischaefter

Closed reed calls.

While approaching the calling location, use the terrain to hide your profile and avoid being silhouetted on the skyline. Quickly and quietly approach with a low profile, sit or lie prone and avoid giving the predator a chance to observe you.

Pay attention to surrounding environmental factors. Wind direction is one of the biggest factors to take into account when selecting a stand. A steadfast rule in predator calling is to observe your downwind side because the predator will try to circle downwind to identify its prey by smell before it approaches. If this is not possible an alternative stand should be chosen. Strong wind decreases the odds for success, primarily because human scent is carried over a much larger area and the sound of the call does not carry well.

Avoid calling from areas in direct sunlight. Blending into the shadows will avoid reflections.

A calling stand should be a minimum of 30 minutes. Choosing a comfortable spot allows the caller to sit or lie still during this time. Predators have keen eyesight and any movement will give away your presence.

Moving from stand to stand into the wind can be an effective calling strategy. By using this method, downwind is always behind the caller.

Calling

Every animal makes distress sounds, which are typically high-pitched with high and low frequencies. The sound may be a whine or cry, which sounds distressful to the predator. These sounds tend to attract predators and are the most commonly imitated sounds used by the predator caller.

Too much volume can be detrimental; the first set of calls should be quieter so the predator is not frightened away. However, weather conditions often dictate what volume is needed.

After settling into calling position, use binoculars to check the area for movement. Generally, callers start with a minute of rabbit-in-distress calls using a low volume. Wait and observe for three to five minutes. If no animal is observed, call again for one or two minutes, increasing the volume slightly. Repeat this sequence three to four times, usually spending 30-45 minutes per stand.

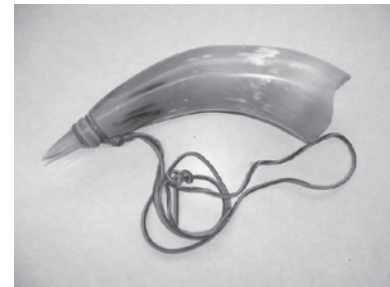

*Open reed cow
horn howler.*

Chris Tischaefel



Bobcat skull.

Brent Ternes



*Open reed deer
antler predator call.*

Chris Tischaefel



Face mask and gloves.

Chris Tischaefter



A variety of
predator calls.

Chris Tischaefter



Red fox skull.

Brent Ternes

If a predator does respond to the call, adjust the volume to a lower level or switch to the squeaker or coaxer call. If the predator does not respond again, wait a while longer in the calling spot to make sure nothing is coming in. If you decide to leave, do so quickly and quietly, as if you'd never been there.

Shooting

It is important to know the range of your gun in order to ensure a well placed kill shot, which is in the heart or lung. Do not shoot at an animal that is out of range. By shooting and missing, predators can be educated and will associate calling sounds with a hunter. Always keep in mind that a standing coyote, fox or bobcat is a much better target than one that is moving.

After a predator is called in and shot, or even called in and missed, it is important to continue your calling sequence. Use either a canine-in-distress or rabbit-in-distress sound. If the predator was missed, sometimes one of these sounds will turn the predator around and provide a second chance. If the predator was hit on the first shot, sometimes continued calling will bring in a second predator to the area.

When calling, two or more predators may come into an area at one time. If two were coming in at once and they both get within gun range, shoot the farthest one, then try to shoot the second one if a well-placed shot is available. If the second one cannot be taken, come back another time and try this area again using a different call.

If a predator comes in, but remains outside of gun range, it probably has been called before or has seen something such as a reflection from your scope or binoculars. It is best to leave the predator alone and sneak out of the area.

After the shot

Once the coyote, fox or bobcat is harvested, it is important to properly handle the pelt. Fur can be ruined in just a few hours if not handled promptly and properly.

Summary

The key to basic predator calling is to follow the process and pay close attention to detail. Learn about the animals, their habitat, surroundings and prey. Be patient and persistent while carrying out the calling sequence. These are the building blocks for effective predator calling and an enjoyable experience afield.

Chapter 15 – Predator Calling

Content Standard – Students demonstrate an understanding of predator calling techniques and equipment.

Explain the common species of furbearers that can be attracted using a predator call.

- List the common species:
 1. _____
 2. _____
 3. _____

Know the common types of equipment used when predator calling.

List some of the equipment that is used when predator calling.

_____	_____	_____
_____	_____	_____
_____	_____	_____

List the types of calls used when predator calling.

1. _____ and _____ calls.
2. _____ or _____ calls.

Know that the techniques and strategies vary for each species and calling location.

1. _____ develops good relations with landowners.
2. _____ teaches you the best locations to find predators.
3. The best time for predator calling is _____ and _____.
4. Planning a proper _____ can result in a productive calling session.
5. Common calling noises imitate an animal in _____.
6. A _____ animal is much easier to shoot than a _____ animal.
7. Proper _____ is important after the shot.

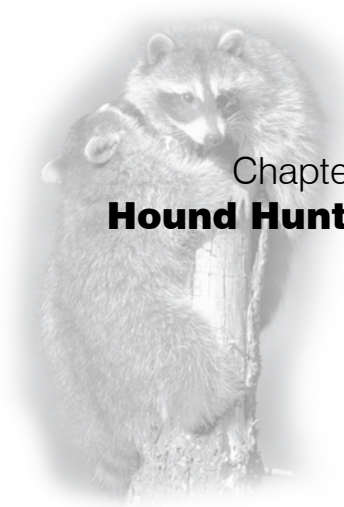

Bobcat “treed” by a
Bluetick hunting dog
(below).

Marty Beard



Bluetick hound barking
up at the “treed” bobcat
(above).

Marty Beard

Content Standard – Students demonstrate an awareness of hunting furbearers with dogs.

Introduction

Furbearers are commonly pursued or captured by trapping, snaring, predator calling and hunting with the use of dogs. This chapter discusses the attributes and techniques of hunting furbearers with the use of hounds, as well as the responsible care and training involved with this type of activity.

History of coursing hounds

The use of hounds to pursue and aid in killing furbearers for food can be dated to 6000 BC. Archeological work done in Ca-Huyuk, Turkey, revealed a sanctuary decorated with hunting scenes. The dogs depicted in the art work as assisting with the kill had long legs, delicate muzzles and deep chests. The dogs in the illustrations may have been the ancestors of the modern day Greyhound breed.

Kings, rulers, and presidents have owned Greyhounds for the main purpose of observing the chase. In the 1800s, many people owned hounds to protect livestock and to capture furbearing animals. As time progressed, the use of pursuit hounds for these reasons slightly diminished, with more effort placed with dog racing and coursing trials. The importance of capturing furbearing animals is slightly diminished in modern times.

While stationed in the Dakotas, General George Custer had 26 coursing hounds, some of which were purebred Greyhounds. General Custer coursed these hounds from Mandan to the Black Hills, to Nebraska and then to the Flint Hills of Kansas. General Custer’s favorite hound was named Byron, which commonly slept with him and his wife Elizabeth. After the battle of the Little Bighorn in 1876 in which General Custer was killed, the hounds were left at Fort Lincoln and used by the residents to catch game.

What is “coursing?”

Coursing hounds pursue game first by sight. If the hound loses sight of the animal, the hound will trail by smell until sight is gained. A conditioned Greyhound can reach speeds of 45 miles per hour for a distance of about ½ mile, and most chases average about 2 miles.

One to three hounds are used during coursing, and the size of the pack depends on the type of game being pursued. Game that commonly is pursued includes white-tailed jackrabbits, red foxes and coyotes. When pursuing a coyote, a special hound with killing capability is included in the pack. Most packs can sustain two hunts a day before the dogs become exhausted.

Coursing begins by traveling on foot, horseback, or by vehicle until game is spotted. Coursing hounds may spot game as far away as 600 yards. The hounds are then released and the chase begins. Coursing hounds make up the distance very fast due to their athletic ability and experience in heading off the game. Each coursing is different due to the type of game and the landscape.

Know that there is a variety of coursing hound breeds.

Common coursing hound breeds include the Afghan, Borzoi, Greyhound, Rampur, Polish Hound, Ibizan, Irish Wolfhound, Whippet, Scottish Deerhound, Rhodesian Ridgeback, and Saluki. The most popular coursing hound in North Dakota is the Greyhound.

The grace of the hound traveling across the prairie at 35-40 mile per hour is exciting to the breeders and keeps the coursing activity alive. The hounds are similar to track athletes with well toned muscle, very little body fat, and alert to any movement. Hounds vary in size depending on breed. Females can weigh between 45 and 70 pounds, while males vary from 58-90 pounds.

Coursing hound training begins at about eight months of age. Running and endurance are built to improve a coursing hound's performance. The hound will learn from other hounds in the pack as to how it will trail or kill. Coursing hounds perform at their best for about five or six years.

History of treeing hounds

The development of the American hounds originated with colonists who brought them from England. The early American settlers quickly realized the value of hounds for pursuing wild game.

Because of the lack of tree climbing game in Europe, a trailing hound with a strong treeing instinct had not been developed. In North America there was an abundance of game that would climb a tree if pursued closely by hounds. Such game included bears, cougars, bobcats, gray foxes, opossums, raccoons and mink. For many years various breeds of fox hounds, fox hound and mixed hound-terrier crosses and dogs of unknown ancestry were used as tree dogs.



Working together produces results.

Marty Beard





Hunting with the family.

Marty Beard



Bobcat mount.

Brent Ternes

Early breeding records of the open trailing tree hounds are extremely vague. Because information has been passed down from father to son, much information has been lost.

Presently, the United Kennel Club (UKC) recognizes six breeds of coon hounds. The breed descriptions of these six coon hounds are taken from the official UKC standards.

Know that there are a variety of breeds used to hunt and tree furbearers.

Black and Tan

The oldest of the coon hound breeds is the Black and Tan. This breed often is thought of as the “Grand Old Breed” of the coon hound world.

The Black and Tan is hard to fault as a coon or big game dog. They are fast on the trail and one of the most vocal of all hounds. Black and Tans possess a superb voice and have a strong treeing instinct.

The modern hunting Black and Tan is built for speed, while it retains a good measure of its “hounchy” appearance (i.e. long ears and sad eyes). Black and Tans have a strong, rather short body, with muscular hindquarters and a broad, powerful chest. The Black and Tan is a medium-sized hound; males measuring 23-25 inches at the shoulders and females measure an inch less. They weigh anywhere from 40-60 pounds. Their legs are straight and strong, and the feet catlike, well knuckled and heavily padded.

The head of the Black and Tan is broad and well rounded across the dome, the muzzle square and deep. The eyes are clean, large and of dark brown color. The ears are long with fine texture and set low on the head and should come just past the tip of the hound’s nose.

The hair coat of the Black and Tan usually is finer and shorter than the other hound breeds. This gives them a glossy finish that is very beautiful; however, some hunters say this type of coat may be a drawback when hunting in cold snowy climates. The color of the Black and Tan is solid jet black, except for tan points over the eyes, and tan on the chest and feet. Some white on the chest is permissible, but not desirable according to UKC standards.

Bluetick

The Bluetick breed is of comparatively recent origin. It was included in the English coon hound breed until it was granted separate registration by the UKC in the mid-1940s. The



Bluetick breed can be traced to the early French Gascony Bluetick as far back as 1200 AD. These hounds were used to pursue stag and boar in France and England.

The Bluetick is one of the most impressive and houndy of the coon hound breeds. The Bluetick is a superb cold-trailing, open-voiced bawl-mouthed hound that seems to have treeing instincts beyond any other coon hound breeds. They are extremely large, heavily muscled, with the appearance of great strength and ruggedness. Their bodies are a bit longer in relation to their height. Their shoulders and chest are broad and well-muscled, and the hindquarters are powerful as well. The legs are heavily boned, straight, and have good, well-padded hound feet.

Male Blueticks measure 26 inches at the shoulders and females measure 21 inches. They may weigh anywhere from 45-80 pounds.

The head of the Bluetick is heavier in appearance than the Black and Tan. The muzzle is square and deep. The eyes are large and dark brown in color. The ears are set low on the head and should come just past the tip of the hound's nose.

The Bluetick's coat is its most distinctive feature. They are almost solidly ticked with black, which, when mixed with white, give them their characteristic "blue" color. The Bluetick usually has a black head, black body spots and tan trim.

English

The English breed has many variations, including the old Blueticks and Redticks. The English breed became a formally registered hound in 1900, consisting of mainly Blueticks and Redticks. However, more and more single registered hounds (hounds that have no record of breeding) have been admitted, including Treeing Walkers and Blueticks.

Because there are so many different hounds in this breed, there also are many different working characteristics. Working characteristics include cold, slow trailers that hunt close as well as those that cover a lot of territory (wide-ranging) type hounds.

Currently, the English hound standard is a lighter, smaller dog than the Bluetick breed. It is difficult to describe the general appearance of the breed because there are so many different types within this breed.

The ideal English hound is medium-sized with typical hound proportions, well-muscled and built for speed and stamina.



A raccoon "treed" by two Treeing Walker hunting dogs (below). Marty Beard



Two Treeing Walker hunting dogs barking "treed" at a raccoon (above). Marty Beard



Marty Beard

Night hunting head lamps.

The English measure 21-25 inches at the shoulder and weigh 45-60 pounds.

The head, like the body, is of the average hound type, broad across the skull, square in the muzzle, ears set low and of medium length, eyes large and widely set.

The texture and quality of the English coat is identical to that of the Bluetick, but has more color variation. Colors include bluetick, tan and white, and black and white; however the predominant color is redtick.

Plott Hound

The Plott Hound has one of the more interesting histories of any of the hound breeds. The lineage of the modern Plott Hound goes back to the boar hounds brought from Germany in 1750 by Jonathan Plott. This breed has been kept fairly pure throughout the years by the Plott family. The Plott Hound was recognized by the UKC as a registered breed in 1946.

The ears of the Plott hound are generally higher-set and shorter. The Plott hound has a higher-pitched chop voice reflecting its less houndy physical type.

The Plotts have among the heaviest, thickest and most protective coats of the coon hound breeds. This dense undercoat makes these hounds great for cold climates. Most Plott Hounds are solid brindle (mottled or striped effect) in various shades of brown and black, or grayish brown.

The Plott hound breed is a bit smaller on average than the other coon hound breeds. The Plott hound measures 21-25 inches at the shoulder and weighs 45-60 pounds.

Redbone

The Redbone traces back to the Redbone strain of Foxhounds of the last century. During the first half of the 20th century, the Redbone gained notoriety among the coon hounds and was admitted into the UKC register in the early 1900s.

Redbones typically exhibit an excellent load voice, which may be a bawl in some strains and chop in others. They have cold-trailing noses and a well-developed treeing instinct.

Redbones have large, powerful bodies, long, straight legs, powerful hindquarters, and a stylish tail carriage. The head of Redbones is not as houndy as some of the other breeds. The ears are set somewhat higher and the muzzle and head are smaller in appearance.



Redbones are among the most impressive looking hounds because of their solid red coat, usually a deep red; it's their most distinctive feature.

Redbones measure from 21-26 inches at the shoulder and weigh 45-75 pounds.

Treeing Walker

The Treeing Walker became a registered breed in the mid-1940s; predominately originating from the Walker Foxhound breed. Practically all of the early individuals of this breed were working Foxhounds. Due to their treeing instinct and lack of speed, they were primarily used for treeing raccoon.

The hunting characteristics of the Treeing Walker are quite different from most of the other coon hound breeds. When tracking gets tough, they tend to range out to pick up a hotter scent rather than stay close. Most Walkers have excellent treeing instincts and can identify which tree the raccoon actually is in faster than other breeds.

A wide range of colors is evident in the Walker breed; the color most favored is the white background with black spots and tan markings. Like the well-colored beagle, many Walkers have a black saddle back with a red head and markings on a white background.

Treeing Walkers measure 21-25 inches at the shoulder and weigh 40-70 pounds.

Know that responsible dog care and training is essential to furbearer hunting.

Selecting a hound

With the many breeds and strains of hounds, there is a type of hound to match different hunting styles and needs. After determining the style of hunting and size of an area, several hound characteristics should be considered. Characteristics include hound hunting range, hound voice, silent or open trailer and cold or hot trailing nose.

With this many selections, one may get the idea that he or she can get the perfect hound, however there is no such thing. Hounds have unique characteristics; the same litter may consist of a cold nose, hot nose, semi-silent and an open trailer. Hunting style and commitment will determine if an older trained hound, a started prospect or a new puppy is best. The best advice for getting a puppy is to choose one whose parents possess a hunting style you prefer.



Walker Hound barking at a "treed" raccoon. Marty Beard



Treeing Walker puppy. Marty Beard



Truck mounted dog boxes. Marty Beard



Tracking antennas and dog collars.



Remote training dog collars.

Training

Training a puppy will take many hours of hard work; however, the results will be very rewarding. A well-mannered and obedient hound is more enjoyable to hunt with than a disobedient hound.

The most widely used method of training is to hunt the puppy with an experienced coon hound. Ideally, the puppy will follow the experienced hound and learn by example. The drawback of this method is the puppy may pick up any bad habits or be frightened if the experienced dog is overly aggressive at the tree.

An alternate method is to use raccoon scent on a rag and drag it to make a scent trail. The trainer releases the puppy on the scent and encourages the puppy to follow the trail. The trainer should progressively make the trails longer and more complex. However, this method may tempt puppies to follow unwanted game. Care must be taken not to overdiscipline as a shy or scared hound will show little desire to hunt to its full potential.

Hound care

Hound care is a very important aspect of hunting. A hound that is well fed and cared for will most likely reach its full potential.

The hound should have an insulated dog house with plenty of bedding. Hay works best as it doesn't break down as fast as straw. Blankets are a poor choice as they retain moisture and harbor insects.

The kennel floor should have proper drainage and be cleaned daily. This is important to keep the hound healthy and free of parasites.

The hound should be fed a well-balanced dog food. This is important to maximize peak performance. Learn the hound's needs and feed accordingly; each hound has different dietary needs. Fresh water always should be given, especially in hot weather.

Veterinary care and services are important. Vaccinations should be given yearly to protect the hound from common diseases. Parasite protection is very important to keep the hound in peak performance. Hounds can be infected with many types of worms that can weaken or kill the animals.



A collar with the owner's name and phone number on it will help a person identify the hound should it become lost.

Know that responsible hunting requires proper equipment and to exercise safety.

Equipment

The equipment needed for raccoon hunting can be as simple as one hound and a flashlight. However, a lot of high-tech equipment is now available.

A "dog box" is important to keep the hound safe during travel. The box keeps hounds from falling or jumping out of the vehicle and will keep them warm and dry during bad weather.

A tracking collar is a device placed on hounds that enables hunters to determine where their dogs are located. The collar transmits a signal to a receiver held by the hunter, which is converted to an audible beep. Tracking collars help locate the hounds and furbearers during the chase, or when they venture out of sight or hearing range. They also help hunters and hounds that become lost.

A dependable hunting light is important if hunting at night. A four or six volt head lamp is recommended. A red or amber filter over the lens can be removed once the hound has treed.

Safety

Hunters should be concerned with the safety of their hounds as well as themselves. Busy roads are the biggest danger hounds will encounter. Lighted or reflective collars should be worn by the hound.

Gun safety also is very important while raccoon hunting. The gun should not be loaded until the hunter is at the tree and is ready to kill the raccoon. The gun always should be pointed in a safe direction and hunters must know what is beyond their respective targets.

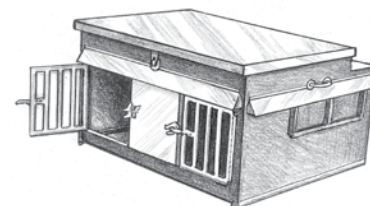

Dog box.

Joe Goodman

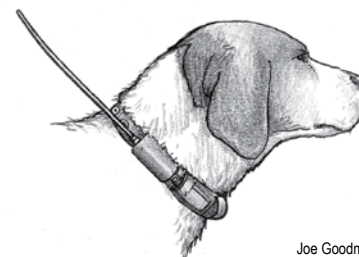

Tracking collar.

Joe Goodman

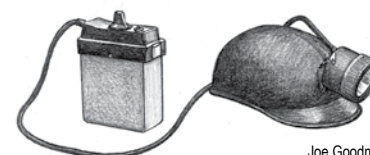

Night light.

Joe Goodman

Chapter 16 – Hound Hunting

Content Standard – Students demonstrate an awareness of hunting furbearers with the use of dogs.

Know that there is a variety of coursing hound breeds.

- List five breeds of hounds commonly used in coursing.
 1. _____
 2. _____
 3. _____
 4. _____
 5. _____
- The _____ is the most common breed used in North Dakota.

Know that there are a variety of breeds used to hunt and tree furbearers.

- List five breeds of hounds commonly used to hunt and tree furbearers.
 1. _____
 2. _____
 3. _____
 4. _____
 5. _____

Know that responsible dog care and training is essential to furbearer hunting.

- Your choice of hound should match your _____ style.
- The most productive way to train a puppy is with an _____ dog.
- Caring for your hound requires routine visits with a _____.

Know that responsible hunting requires proper equipment and to exercise safety.

- A _____ is used to transport a hunting dog in a vehicle.
- A _____ collar is worn by a dog that hunts at night.
- _____ headgear is worn at night to provide light when needed.
- While hound hunting, a _____ should not be loaded until it's time to shoot.

Chapter 17

Using Furbearers



Content Standard – Students demonstrate an understanding of the full value of harvested furbearers.

Introduction

Responsible trappers and hunters make full use of furbearers they harvest. The primary value of a pelt is for clothing, but furbearers also are used for human food, pet food, glands, skulls and fertilizer. Making the most of what you catch is one of the many responsibilities that come with fur hunting and trapping.

The personal reasons for hunting and trapping are as individual as each of us. Regardless of what is individually important, hunters and trappers must respect and honor the life we affect. Whether your activity is for personal reasons or those considered in professional wildlife management, each animal we harvest is a gift. Treating the animal as such is the ultimate respect for the individual animal and for the resource.

A commodity in a global market

Furs are a worldwide commodity. Their value at a given time is determined by supply (the number of pelts for sale) and demand (the number of pelts needed for manufacturing garments). Much of the demand for furs comes from markets in Europe, Russia and Asia. Therefore, the economic health and buying power of these regions affect their demand for raw furs and the return you receive for your pelts.

Manufacturers usually hire a broker to fill orders for pelts. When possible, buyers deal directly with brokers to resell your pelts. Buyers who don't have contracts with brokers resell your pelts to other buyers. This might take place several times before your pelts make their way to a broker.

Buyers' profits come from selling your pelts for more than they paid after accounting for their time and expenses. They usually operate on a narrow margin, and a sudden shift in supply or demand can increase their profit or turn it into loss.

While it's rare to meet a trapper without a story about being "taken" by a fur buyer, it's even rarer to find a fur buyer who stayed in business by cheating customers. Established fur buyers provide a fair market return to keep your business. The return can vary from buyer to buyer, but it's usually in the same ballpark. To get the best possible return for your furs:



Silvertip Productions

Beaver caught in a body-gripping trap.

Taxidermists often look for high quality specimens to mount.

Check regulations and obey the law.

Animals with unusual pelts, such as albinos, may bring top dollar from taxidermists, but little from a fur buyer. The same may hold true for lesser-trapped species, such as ringtails.



Fox pelt on stretcher. Silvertip Productions

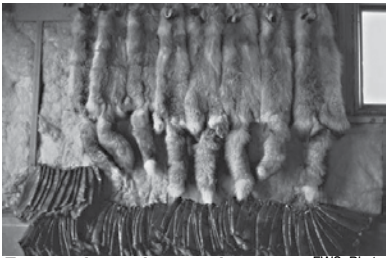

Fox and muskrat pelts. FWS Photo

- Monitor market conditions by following reports in trade magazines.
- Shop around if you have doubts about an offer – you aren't committed to taking it.
- Take pride in the way you handle your furs – clean, well-handled furs without damage are worth more in any market.

At auctions, the sponsors charge customers a commission – usually a set percentage of your proceeds. This fee pays for the sponsor's expenses and includes their profits. Most state trapper association-sponsored auctions allow you to set a minimum bid price for your furs. International auctions don't allow you to set a minimum bid, but the sponsors can withdraw a lot if the price doesn't meet their expectations. After all, their profits are tied directly to yours.

Know the advantages, disadvantages, and procedures for four ways to sell furbearers or pelts.

Fur harvesters have four choices for selling fur. There are advantages and disadvantages for each method. Options include:

Local fur buyers

Local fur buyers will know the most about furbearers in your area. They can be a valuable source of information and experience.

If you live close to a fur buyer you can sell whole animals as you catch them. This is an advantage if you don't have a good place to process fur and store it. A local buyer also can give you specific tips on fur handling, or possibly show you the best techniques. Local buyers also buy "green" pelts. Green pelts are skinned but not fleshed, stretched and dried.

If you are fortunate enough to live near several fur buyers you can shop around for the best return. This generally is best if you have a large number of furs. A disadvantage of selling to a local buyer is the return. A local buyer is a "middle man" who must buy low and sell higher to make a living.

Some local buyers advertise in area newspapers, but many rely on "word of mouth" for new customers. Asking experienced trappers or fur hunters is a good way to locate buyers in your area.

Traveling fur buyers

Traveling fur buyers work for larger companies. Some of the larger companies set up "truck routes." Their buyers travel from town to town, making stops at designated places and times.



Most routes are run weekly or every other week. You can find out if a stop is scheduled in your area by checking the local newspaper beginning about two weeks before season opens.

You may be able to meet them at a local sporting goods store on scheduled dates, or make an appointment for them to visit you. Traveling buyers make it convenient for you to sell fur, but the return you receive may be lower than the return you could get selling by mail or at auction.

Traveling buyers will purchase whole animals, pelts that have been skinned but are not fleshed, or pelts that have been fleshed, stretched and dried. Unless you schedule your trapping activities so that your catch is fresh when a buyer stops in town, you'll need to freeze your furs or flesh, stretch and dry them so that they don't spoil.

Selling by mail

Some trappers sell their fur by mail. Mail buyers advertise in trapping magazines. Selling by mail saves you the time and cost of driving a long distance. Mail buyers will usually make payment in a few days. Mail buyers do not charge a commission, and some will pay the shipping costs. Some also will give you 10 days or so to decide if you like the offering return. If not, they will ship your furs back to you.

Return lists for pelts from mail buyers can be deceiving. Returns can change, or a buyer may give you a good offer for some of your furs and downgrade the rest. When selling by mail you lose the advantage of having competitive bidding for your fur.

Fur auctions

Auctions are only an option if your furs are fleshed, stretched and dried. Some state trapping associations sponsor auctions as a service to their members. These auctions are advertised in newsletters or magazines that come with your membership.

All of the international auction houses advertise in trapping magazines. Contact a company's office or one of its representatives to set up an account. They'll assign an account number and provide shipping tags, receipts, auction schedules and instructions. When your pelts are fleshed, stretched and dried, you can ship them to a receiving station or, in some cases, deliver them to a representative who collects furs along a truck route before each auction. Payment for furs sold at auction is made within 30 days. All unsold pelts are stored for future auctions. If requested, the company will return unsold pelts for the cost of shipping and handling.



Trapper bagging fresh muskrat for freezer.

Silvertip Productions



Beaver castor glands.

Silvertip Productions

Using all of the animal is the right thing to do.



Coyote skull.

Brent Terres

Each trapper must decide when and how to sell fur based on current returns, market forecasts, convenience and cost. Other trappers, magazines, and trapping associations can provide helpful information. The more you know about grading fur and market conditions, the better the chance you will earn a good return for your work.

Know that fur buyers will grade animals or pelts by primeness, size, color, texture, fur density, damage and other characteristics.

The value of a pelt is determined by its size, fur density, damage, color and clarity. Standards for these criteria differ among species and regions.

To determine size of cased skins that are stretched to meet industry standards, measure the pelt along the back from the tip of the nose to the nearest point that the leather ends at the skirt (bottom of back).

Larger-sized animals of one species generally bring a better return than smaller ones. Pelt primeness is a major grading factor. Trapping seasons are set to harvest furbearers when they are most often prime. Summer pelts are thin, flat, and have little to no value. Prime pelts have dense underfur and fully developed guard hairs. The skin, or leather, side of an unprimed pelt is dark blue or black because the hair follicles are not fully developed. Later in the season furs may not be worth as much because of fading color, hair loss, rubbing or curling. Furs also can be damaged by careless handling.

Grades reflect the degree of primeness and, to a lesser extent, damage (in many cases, damage is evaluated separately). The best pelts are graded as selects; the worst as fourths. The best pelts are graded as “Ones” (I) or “Ones part Twos” (I pt. II). Seconds are lower quality due to slight damage, color, or other factors. Thirds (IIIs) are badly rubbed. Unprimed and fourths (IVs) are of very little, if any, value.

Know that meat from some furbearers can be used for human consumption.

Many people enjoy eating meat from healthy beavers, muskrats, raccoons, nutria, opossums, and bobcats. Freshly caught, skinned and gutted animals will taste the best. The front and hind quarters and back meat are most commonly eaten. Avoid meat from any animals that appear sick. Keep the carcasses clean and thoroughly cook any wild game you intend to eat.



Fried Raccoon

Trim off all the fat and remove glands from a young, dressed raccoon (glands are soft, whitish and located under each front arm and the hindquarters). Cut into small pieces suitable for frying. Place meat in a bowl and cover with milk. Let stand for 30-40 minutes. Remove meat from milk and roll in flour which is well seasoned with salt and pepper. Fry in deep fat until brown.

For gravy, pour off most of the fat, leaving just enough to cover the bottom of the pan. Add three tablespoons of seasoned flour and brown. Pour about 2 cups of milk (used for soaking the meat) into browned flour and cook until thick while stirring constantly.

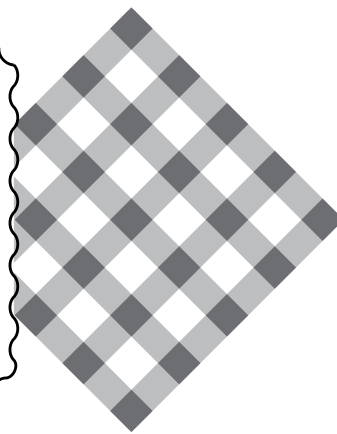

Roast Raccoon

Place the dressed raccoon in a large pot and cover with water. Put one or two pods of red pepper in the pot and salt the water to taste. Parboil until tender, then remove and place in a baking pan. Sprinkle with black pepper and flour. Add some of the stock to the roast as it is being baked. Onion may be added if desired. Cook until brown.

Baked Iowa Corn-Fed Raccoon

Dress raccoon shortly after it's killed. Remove as much fat as possible. Soak in salt water overnight and cook the following day or freeze until ready to use. Young raccoons may be left whole and are best for this recipe.

2 young raccoons, dressed (remove fat & glands)	1/3 pound fat back or salt pork, sliced
1/2 t. salt on each raccoon	1/2 t. pepper on each raccoon
3 lemon slices about 1/4" thick	2 large onions, sliced
1/4 t. each of marjoram, thyme, savory	2 cloves garlic, sliced thin
1-2 cups chopped celery	1-2 bay leaves
2 quarts strong bouillon	2 chilies

Place the carcasses on a rack in a roaster (electric, self-basting types work great). Salt and pepper and add bay leaves and other herbs. Strip with salt pork or fat back. Place lemon and onion slices over the meat. Sprinkle with garlic. Add chopped celery. Cook at 350 degrees for an hour or until done.

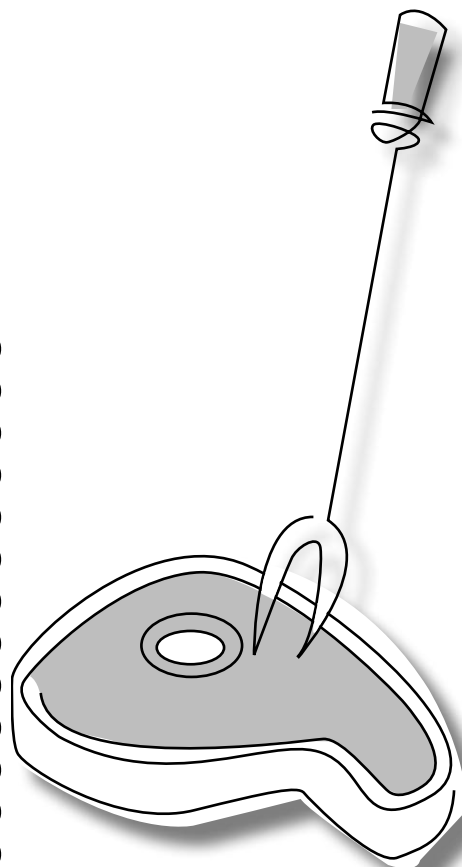

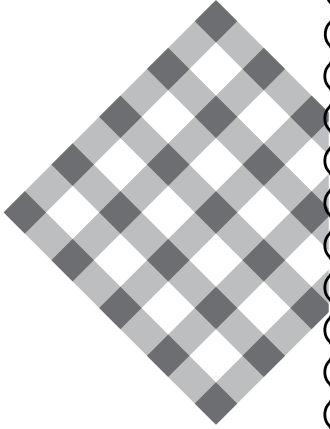

BBQ Raccoon

- 1 raccoon, dressed (remove fat & glands)
- 1 rib celery
- 3 cloves garlic, chopped
- 2 large red onions, quartered
- 1 large apple, quartered
- 3 hot red peppers
- 1 cup vinegar
- 3 tbs. salt

Pull celery apart and wash. Place all ingredients in pot with enough water to cover raccoon. Bring to slow boil and cook until tender or fork goes in easily, about 1-2 hours depending on size of raccoon. Remove meat from pot, cut off front and back legs, cut remainder into 4 pieces. Place on rack, brush with your favorite BBQ sauce. Place in 400 degree oven, turn and baste frequently with BBQ sauce until golden brown.

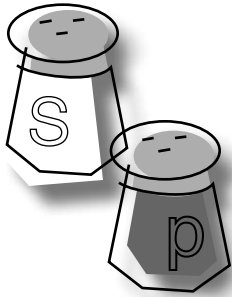

Baked Muskrat BBQ

- | | |
|---------------------------|---------------------|
| 1 muskrat | 3 t. fat |
| 2 t. vinegar | 2 t. tomato ketchup |
| 1/2 clove garlic, crushed | 1/8 t. black pepper |
| 1/2 t. salt | dash cayenne pepper |

Soak muskrat in slightly salted water or in diluted vinegar for 12-24 hours. Wash thoroughly, removing all blood and visible fat. Cut into pieces for serving; drain. Place in greased shallow pan; baste with sauce made of remaining ingredients. Bake uncovered in 325-350 degree oven for 1-1/4 to 1-1/2 hours or until tender, basting every 15 minutes. Place on hot platter and garnish with parsley, celery leaves or curly endive if desired.

Muskrat Stew

- | | |
|------------------------|-------------------------|
| 1 muskrat, cut up | flour |
| salt & pepper | 2-1/2 tbs. butter |
| 7 cups boiling water | 1 t. thyme |
| 1 cup sweet corn | 3 potatoes, cubed |
| 1/4 t. cayenne | 3 medium onions, sliced |
| 2 cups canned tomatoes | |

Roll the muskrat pieces in flour, salt and pepper. Brown in butter. Add muskrat and all other ingredients (except tomatoes) to the boiling water. Cover and simmer for 1-1/2 to 2 hours. Add tomatoes (including juice) and simmer another hour.



Beaver Smothered in BBQ Sauce

1 small beaver	4 tbs. butter
2 medium onions, sliced	4 tbs. vinegar
4 tbs. brown sugar	4 tbs. lemon juice
2 cups ketchup	2 tbs. Worcestershire
1 tbs. prepared mustard	1 cup water
1 cup celery	1/4 t. salt

Dress a young, fresh beaver. Remove all of the glands and as much fat as possible. Place meat in a large roaster and cover with water. Cover pan loosely with foil and cook at 300 degrees. Every 1-1/2 hours, drain the roaster completely (do not throw greasy water down drain). Refill the roaster with fresh water and continue cooking. Repeat this process at least 3 times while cooking for 8 hours. Remove the roaster from the oven and let stand covered with foil for about 1 hour. Drain and remove meat from bones. Place boned meat in a baking dish. The outer layer of meat will be fully cooked; inner layers may be less done and should be placed on top. Cover dish with foil and bake for at least 2 hours at 300 degrees. Prepare BBQ sauce while the meat is cooking (brown onion in butter, then add remaining ingredients and simmer for 30 minutes). Pour sauce over the meat and bake uncovered for the last 45 minutes.

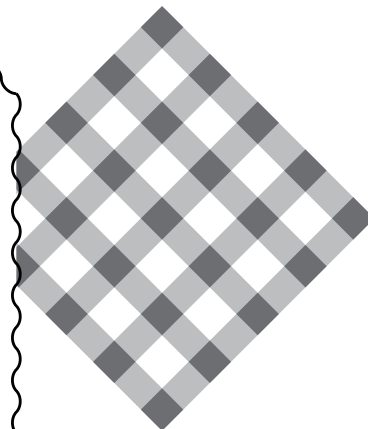

Atlanta Special (Beaver)

Remove fat and glands from a young beaver. Wash, cut up and soak overnight in salt water. Parboil with 1 bay leaf, 2 medium onions and garlic until about half-cooked. Drain, roll in flour and brown in hot fat. Season with salt and pepper. Bake in a covered pan at 325-350 degrees until tender. Gravy can be made from the drippings.

Roast Beaver

1 young beaver	1/2 lb. bacon
3-4 small chilies	1-1/2 cups chopped celery
6 carrots, chunked	pepper
4 onions, sliced	salt
thyme	basil
Bouillon	1 lemon, sliced
marjoram	

Dress beaver; remove fat and glands; wash. A 10-12 pound beaver will fit in a roaster whole. If larger, cut into 4-6 pieces. Place meat on a rack to keep it off the bottom. Sprinkle with salt and pepper to taste. Lay strips of bacon over the meat, then slices of lemon. Add the vegetables, sprinkling them over and around the meat. Slice onions very thin and scatter over the vegetables and meat. Add chilies and bay leaves. Cover and cook until done, which will depend on the size of the beaver. This generally takes 2-3 hours or more. Remove lid for the last 30 minutes.



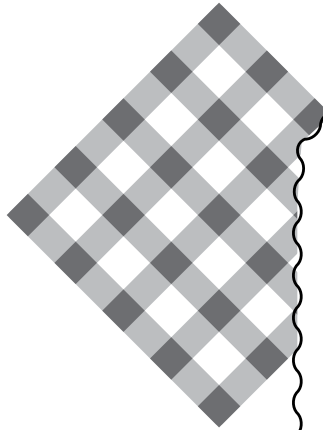

Game Sausage

3 lbs. boned, ground game meat
1 t. course black pepper
1/2 t. allspice
2 lbs. ground bacon
1/2 oz. salt
1/2 t. nutmeg
2 dried red peppers (minced)
1/2 t. cayenne pepper
casing (optional)

Mix all ingredients thoroughly. Stuff or form into patties. Can be used immediately or frozen. Are excellent smoked, grilled or baked in a 375 degree oven for 40-45 minutes.

Jerky

1 bottle Wright's liquid smoke
2 t. Lawry's seasoned salt
1 t. tabasco sauce
1 t. black pepper
garlic to taste

Cut meat into thin slices. Dip in sauce and lay out on a cookie sheet. Salt and let stand overnight (in a refrigerator). The next morning, bake at 200 degrees for 1 hour; turn and bake for another hour. Sprinkle with seasoned salt when done.

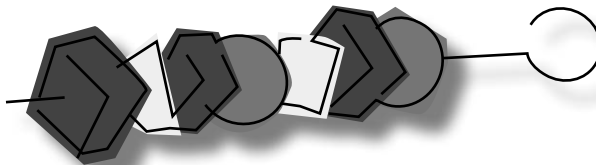



Know that meat from some furbearers can be fed to dogs or used for food at mink farms.

Some trappers feed muskrat and beaver meat to their dogs. Check with your veterinarian to see if furbearer meat would be a good choice for your dog's size, breed, age and general health. Fur ranchers may buy muskrat and beaver carcasses for mink food.

Know that glands from some furbearers can be made into lures or sold for commercial use as perfume.

Castor glands and oil sacs are found below the skin in the anal area of both male and female beavers. Castor glands and oil sacs are valuable and can be removed. Trappers can sell the glands for use in perfume or trapping lures.

Mink, weasels, skunks, otters and fishers have anal glands that contain a strong musk useful in making trapping lures. The glands should be cut loose with minimal squeezing and kept cool or frozen. Weasel glands particularly are good for attracting mink, otters, weasels, foxes and coyotes.

Fox and coyote anal glands and foot pads are used in lure-making for those species. Glands of raccoons, opossums, badgers and muskrats are also sometimes used.

Know that furbearer skulls and other animal parts have value.

Furbearer skulls are often needed for science classes or nature centers. Dermestid beetles are useful for cleaning skulls or other bones you want to save.

Some companies specialize in animal parts that are used for arts, crafts and novelties. Check trade magazines for advertisements and contact companies for prices and instructions on handling. Universities and museums also collect and display animal parts for educational displays.

Describe why it is important to properly dispose of any animal parts that remain after processing

Responsible trappers use as much of each animal trapped as possible. Animal carcasses or parts can be used as baits or attractants when trapping or snaring. Any remaining parts should be taken to a rendering plant, used for fertilizer or buried. Improper disposal could lead to human or animal health problems. Other people could be offended by seeing animal carcasses and parts. Disposal methods may be regulated in some areas, so it is best to plan your carcass disposal prior to the start of the season.

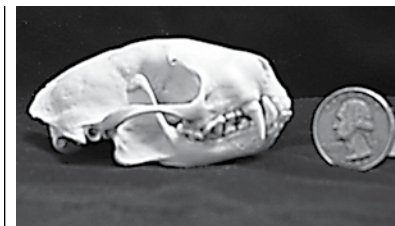

Skunk skull.

Brent Terres

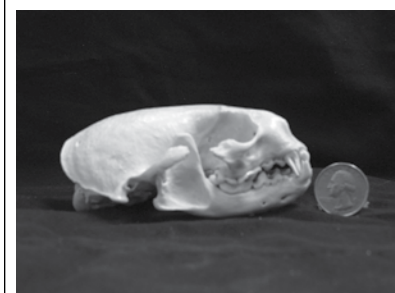

Badger skull.

Brent Terres

Chapter 17 – Using Furbearers

Content Standard - Students demonstrate an understanding of the full value of harvested furbearers.

Know the advantages, disadvantages and procedures for four ways to sell furbearers or pelts.

- List four ways to sell fur.
 1. Local _____.
 2. Traveling _____.
 3. Selling by _____.
 4. Fur _____.
- Choose the method you think you will use to sell fur, and explain why in the space below.

Know that fur buyers will grade animals or pelts by primeness, size, color, texture, fur density, damage and other characteristics.

- Trapping seasons are set to harvest furbearers when they are most often _____.
- Prime pelts have dense _____ and fully developed _____ hairs.

Know that meat from some furbearers can be used for human consumption.

- Name three kinds of furbearers found in your state that can be eaten by people.
 1. _____
 2. _____
 3. _____

Know that meat from some furbearers can be fed to dogs or used for food at mink farms.

- Name two furbearers used to feed dogs or mink.
 1. _____
 2. _____

Know that glands from some furbearers can be made into lures or sold for commercial use as perfume.

- Male and female beavers have _____ glands and oil _____ that trappers can sell.

Know that furbearer skulls are sometimes needed for science classes or nature interpretation.

- Dermestid _____ are useful for cleaning skulls and other bones to use in science classes.

Describe why it is important to properly dispose of any animal parts that remain after processing.

- Improper disposal of animal parts could lead to _____ or _____ health problems.



Fur handling tools: comb, brush and fork. Ohio DOW



Knives. Ohio DOW

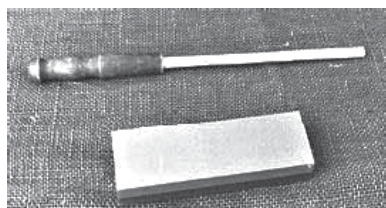

Knife sharpeners. Ohio DOW

Content Standard – Students demonstrate an understanding of the knowledge, skills and equipment needed to safely skin animals and prepare pelts for market.

Introduction

Proper fur handling is the key to getting a good return for your product. Furbearer carcasses can spoil quickly, especially in warm weather. If you don't know how to skin and prepare pelts you may want to consider selling your furs unskinned on the carcass. Selling your animals on the carcass is less work for you and more work for the buyer. You will receive a lower price for unskinned furs. If you do decide to skin your own catch, proper fur handling begins in the field.

To avoid spoilage, sell unskinned animals daily if the outside temperature is above 40 degrees, every two or three days if below 40 degrees and the animals have been left hanging. You can freeze whole animals if you have the room. Make sure that they are clean and dry. Animals that were killed recently should be allowed to cool long enough to let their body heat escape before placing them in the freezer. Small animals should be wrapped individually in sheets of newspaper. Place newspaper or cardboard between animals that are too large to wrap.

Never seal animals or pelts in plastic bags without proper cooling. Plastic will trap heat and moisture and spoil the pelt. Fur is a great insulator and piling animals in a freezer will cause those in the middle to spoil. If you have too many, rotate animals from the middle to the outside after 12 to 24 hours.

If a furbearer is trapped in water it should be removed from the trap and rinsed clean of any dirt, mud or vegetation. Shake excess water from the animal, and stroke it from head to tail with your hand to remove as much water as possible. If snow is available, roll the animal vigorously in it to take the moisture from the fur. If it is below freezing don't lay a wet animal on ice or a metal surface. The guard hairs of the pelt will freeze to ice or metal, damaging the pelt when you pick it up. Animals can be placed in a burlap bag to protect the fur while transporting it back to the fur shed. If an animal's fur is still wet when you get home, hang it up by the head or forelegs in a cool place to dry. Circulating air with a fan will reduce drying time. Generally, pelts should be dry before being skinned and placed on a stretching frame.



If a furbearer is trapped on land and already is dry, simply place it in a burlap bag to protect the fur while transporting it back to the fur shed. Brush or comb the pelt to remove any burrs or dirt prior to skinning. Land furbearers may have external parasites such as fleas, ticks or mites, so keep the carcasses in a place where they won't contaminate your house, clothing or vehicle.

Explain the importance of wearing latex gloves when processing furbearers

Furbearers should be skinned as soon as possible after they are trapped. The pelt is easier to remove and less likely to be damaged when the animal is fresh. Before skinning, remember to put on a pair of latex gloves. The gloves will help protect you from any diseases the animal might be carrying.

Explain the terms “cased furs” and “open furs”

Pelts are prepared for the market by skinning in one of two ways: cased or open. Except for beavers and sometimes badgers, all furbearers should be skinned cased.

Case skinning is much like removing a sweater or sweatshirt by grasping the bottom and turning it inside out as you pull it up over your head. To do this with a furbearer pelt, make a cut from the top of the foot pad along the inside of one back leg to the top of the foot pad of the other back leg. Then simply remove the pelt from the carcass by turning it inside out, skinning down over the back legs, forelegs, and head.

To skin a beaver or badger using the open method, make a cut on the underside of the animal from its chin to the base of its tail. Removing the fur this way is much the same as you would take off a coat. Fur handlers also use a technique that combines case and open skinning to make beaver and badger fleshing easier. Ask your instructor to explain this technique.

Explain the terms “market fur in” and “market fur out”

Fur markets want cased-skinned, dried furs presented either “fur in” or “fur out,” depending upon the species. “Fur in” means that the fur side of the pelt is on the inside when the pelt is sold. “Fur out” is just the opposite: The fur should be on the outside of the pelt, the skin on the inside. Check with your fur buyer to see how the individual pelts are to be prepared for market.

Most fur buyers are glad to explain proper fur handling techniques and preparation to you since it means more profit for both of you. Don't be afraid to ask.



Skinning gambrel.

Chris Tischaefter

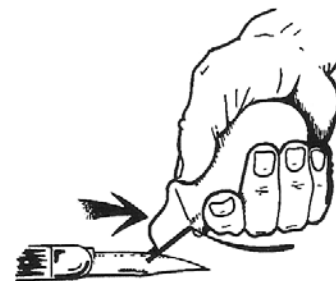

Knife sharpening.

Illinois Department of Natural Resources

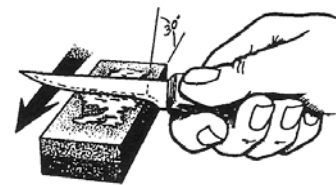

Knife sharpening.

Illinois Department of Natural Resources



Plastic tail puller and opener.

Chris Tischaefter

Explain why the tails of some furbearers are split and left on the pelt while the tails of others are removed

Furbearers with furred tails should have their tails split from the underside with a knife and the tail bone removed. A tail-stripper comes in handy for this purpose. The deboned, furred tail should remain attached to the pelt. Tails of furbearers that are not furred should be cut from the pelt at the hairline during skinning and discarded.

Know the purpose of a fleshing beam and fleshing tools.

Once you've skinned a furbearer the next step is fleshing. A fleshing beam is a wooden (or fiberglass) support that holds a pelt when removing meat or fat still on the skin. If not removed, this meat or fat could rot and spoil the pelt.

Once pulled onto a fleshing beam (skin side out), the pelt is scraped with a double-handled draw knife, a single-handled scraper, or other type of fleshing tool.



Knives and sharpener.

Chris Tischaefter

Describe the proper use of wire and wooden stretchers

The final step in preparing furs for market is to place the skinned, fleshed pelt on a wire or wooden stretcher. The term "stretching" may be a little misleading, as the pelt is not being stretched at this point in the process. Rather, it is simply being held in place as it dries so that it does not shrink or shrivel. Most cased-skinned furs should first be placed over a stretching board or wire frame fur-side in. Remember to center the pelt on the board or frame, meaning that the forelegs and belly of the pelt should be on one side of the frame and the eye holes, ears and back should be on the other side. Pull the pelt snug, but not too tight. If you are using a wooden stretching board, secure the pelt in place with a few tacks or push pins near the base of the tail and back legs. Wire frames usually have two metal arms with prongs that hold the base of the pelt taut.



Fur combs.

Chris Tischaefter



Pelting equipment.

Chris Tischaefter

Explain the process of drying pelts and why it is important

Once a pelt has been properly placed on a stretching board or wire frame it should be hung up and dried slowly in a room with a temperature of about 55-60 degrees Fahrenheit. Use a fan to circulate air throughout the room to reduce drying time. Pelts of wolves, foxes, lynx, bobcats,

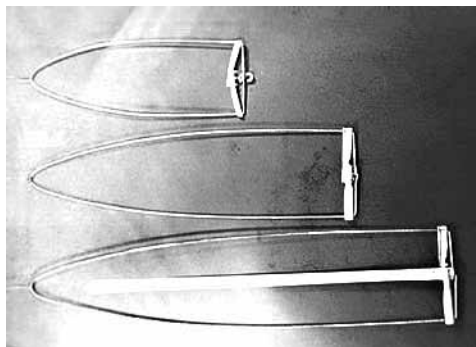

Wire stretchers come in many sizes.

fishers, martens, wolverines, badgers (if cased) and coyotes should be turned fur side out.

You must check the pelts as they dry fur side in. Once the skin is dry to the touch, remove the fur from the stretcher and turn it fur side out. Place the pelt back on the stretcher fur side out and pin it in place to finish drying. The skin may be dry to the touch in as little as one hour for martens, to as long as 10 hours for wolves.

Complete drying of a pelt may take anywhere from just a few days to a week or more depending upon the temperature and air flow. Regardless of how long it takes, a pelt should be completely dry before removing it from the stretching board or wire frame. If not properly dried, the pelt will rot.

Explain the process for freezing pelts

An alternative to stretching skinned pelts is to quick-freeze them. Care must be taken if you choose this method or the pelts could be ruined. Always freeze the pelt flat, fur-side out, with no exposed flesh. Do not roll furs, and never freeze or thaw your fur in plastic. Animals with heavy flesh such as coyotes, raccoons, beavers and badgers should be thawed out for 5-6 hours in a cool room before selling. Never allow frozen green pelts to thaw for so long that the grease melts, or the skin gets slimy. Muskrat pelts should be frozen flat and not thawed at all before selling.

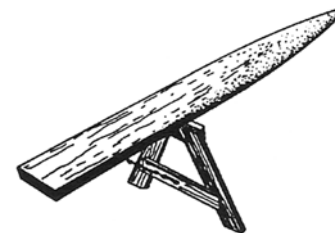

Fleshing beam.

Illinois Department of Natural Resources



Fleshing pelt.

Illinois Department of Natural Resources

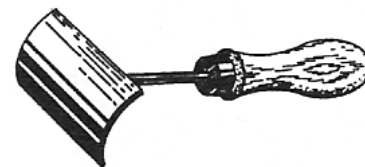

Single hand pelt scraper.

Illinois Department of Natural Resources



Illinois Department
of Natural Resources

**Starting cut for open
skinned beaver.**



Illinois Department
of Natural Resources

**Open skinning
beaver.**



Beaver on board.

Ohio DOW

Small furbearers such as mink and muskrats can be frozen whole, without skinning. Allow whole frozen animals to partially thaw before selling. In the case of selling whole frozen muskrats, only the feet need to be thawed when presenting to the buyer.

Tips for freezing skinned pelts

- Turn the pelt fur-side out and match the belly to the back so that the leather side of the pelt is less prone to freezer burn.
- If the pelts have tails attached, flip the tails under the belly, wrap the pelts in newspaper and lay them flat in the freezer.
- Never wad or roll up pelts to freeze them – the inside can spoil. Never freeze skins inside sealed plastic bags – they collect moisture that can damage the fur.
- Remove muskrat, mink and fox pelts from the freezer about two hours before you take them to a fur buyer – they should still be “frosty.”
- Remove raccoon, coyote and beaver pelts from the freezer about six hours before taking them to a fur buyer – they will be partially frozen.
- Never thaw pelts by laying them next to a heater or fire.

Individual fur buyers may have different instructions for freezing pelts or whole animals. If you know where you intend to sell your fur, check with the buyer for more specific directions on freezing fur.

Take health precautions while skinning

Some furbearers carry diseases and parasites that can be passed on to humans during the skinning process. To avoid health threats, use band-aids to cover open cuts or sores on your hands before skinning wild animals. Wear latex gloves. Disposable latex gloves like the ones used by surgeons are available from pharmacies or trapping supply dealers. When finished skinning, wash your hands well with anti-bacterial soap. Don't handle soda cans or food during the skinning process – they can pass bacteria to your mouth.

Skinning

Skinning animals takes time, but it has some advantages.

If you have limited freezer space, pelts take up less room than whole animals. Most dealers pay more (depending on the species) because it saves them the cost of having someone skin your catch. Meat from some furbearers can be used as bait, eaten or sold. You can use secondary markets for glands, skulls, teeth and claws.

You'll need some basic equipment for skinning. A sharp, high-quality knife is a must. Blades with pointed tips are best except when skinning beavers – rounded tips come in handy for this job.

There are two ways to skin furbearers: open or cased. The open method involves making a slit in the belly skin from the chin past the vent. The cased method involves making a cut from heel to heel and around both ankles, then pulling the hide over the animal's head like you would remove a tight glove or sweater.

Case-skinning muskrat

Muskrats are among the easiest furbearers to skin because the connective tissue that joins the pelt to the muscle is weak.

Some trappers prefer to hang the animal from a gambrel; others feel this is a wasted step. If you use a gambrel, poke the top of one hind foot through a hook. Grasp the tail and make a cut from the base of it (where the fur ends) to the heel of the hind foot that's held by the gambrel. The cutting edge of your knife should face upward and angle away from you, just under the skin. Repeat on the other side.

Make cuts around the ankles of both hind feet. Some people make cuts around the wrists of both front feet, but this isn't necessary. Make a cut completely around the base of the tail where the hair ends.

Work the skin free from the muscle tissue on one of the hind legs. After it's started, push your forefinger and index finger under the pelt toward the backbone, then upward under the tail, pulling the pelt free. Peel the skin away from the muscle all the way across the cut. Follow through with your thumb around the leg bone and start removing the pelt on the animal's belly side.

Pull the pelt downward toward the animal's head. It should come off freely until you get to the front legs. Pass a finger between an armpit and the pelt to loosen it then pull downward until the front leg comes free. Repeat this on the other side.

Grasping the pelt at the tail end, pull downward until it stops at the ears (you'll notice some whitish cartilage where the ears connect to the skull). Make small cuts to separate

Pelting a raccoon



Brush and comb the fur.

Ohio DOW



Lines show where to cut.

Ohio DOW



Cut both legs from ankle to 1" below vent, then around the ankles.

Ohio DOW

Pelting a raccoon (con't.)



Cut bottom side of tail. Start about 1/4 of the tail length down. Wear latex gloves when skinning. Keep your knife sharp.



Pull the pelt off the legs, down to the crotch. Work it loose with your fingers, then cut it away at the crotch.



Pull the pelt off the hips then pull it away from the back and part way down the tail.

the bases of the ears from the skull. Pull downward until you get to the eyes. Use a knife to make small cuts that separate the eyelids at the skull (be sure to leave the eyelids on the pelt). Pull downward until the pelt is free, or make a small cut at the tip of the nose.

Case-skinning raccoon

Make cuts around both ankles and wrists. Some people prefer to cut both front feet off at the wrists with a hatchet. Next, make a cut from the inside of one heel to the other, passing below the vent. Grasp the end of the tail and split the underside toward the vent. If you have a tail stripper, you can start the cut about 4-6 inches from the base of the tail. Continue the cut along one side of the vent until it meets the cut that goes from heel to heel. Make a cut on the other side of the anus, forming a triangle around the vent.

Using your knife, separate the pelt from the muscle around both ankles. You'll need to loosen enough of the pelt to grab it. Pull downward with some force. This should separate the pelt along most of the leg. Repeat this procedure on the other side.

Work the pelt free near the base of the tail. If necessary, cut some of the connective tissue. Peel the pelt away from the tail bone for a distance of 3-4 inches. Place a tail stripper around the tail bone and yank downward with one hand while using your other hand for leverage against the lower back of the raccoon. If the tail bone doesn't pull out, extend your cut a few inches toward the tip of the tail and try again. Split the tail all the way to the tip after the bone is removed.

Tails remain attached to the pelts of raccoons, foxes, coyotes, bobcats, badgers, mink, weasels and skunks. After removing the bone, split the tail along its entire length. Using a guide can help you to make a straight cut.

Pull the base of the tail toward you and run your fist downward between the pelt and the muscle tissue along the backbone. Turn the animal around and loosen the pelt from the belly. If the raccoon is a male, the skin will stop at the tip of the penis; a small cut can be used to separate it from the pelt.

Run your fist downward between the pelt and the muscle tissue along the centerline of the belly. Pull the pelt downward, freeing the sides. It will stop at the front legs. Using a knife, make a slit through the connective tissue at the shoulder and upper arm. Be careful not to cut through the pelt itself.

Loosen the pelt near the armpit by pushing between the pelt and muscle tissue with your fingers. After it's started, cup your fingers from both hands through the opening and pull downward. This should separate the pelt to the wrist, where it will pull free. Repeat this procedure on the other side.

After both front legs are free, pull downward on the pelt. The pelt of young raccoons will usually separate to the base of the skull. The connective tissue on the necks of older raccoons is stronger. You'll probably need to use a knife in some places, but be careful – a light touch with a sharp blade will get the job done, especially if you're applying pressure to the pelt by pulling it downward.

Continue working the pelt downward until it stops at the cartilage that forms the bases of the ears. Cut through the cartilage at a point close to skull. When both ears are free, pull downward until you reach the eyes. Using a knife, separate them from the pelt by cutting carefully next to the skull. Pull downward again to the tip of the nose and make a small cut through the cartilage to free the pelt.

Open-skinning beaver

Make cuts as shown earlier in this manual. Be careful not to cut into the muscle tissue – insert your blade just beneath the skin with the cutting edge facing up and angled away from you. We recommend removing all four feet with a hatchet or heavy-duty knife.

Beavers have a thin layer of fat between the pelt and muscle tissue on the belly. Starting at the edge of the cut you made down the beaver's belly, use a round-tipped knife to separate the pelt and fat from the muscle tissue. Continue this process along the entire length of the beaver – take your time and angle your blade toward the muscle tissue to avoid slicing into the leather.

You'll encounter a thin layer of connective tissue about halfway between the center line of the belly and the legs. Cut through it, leaving the connective tissue attached to the pelt. Continue separating the pelt until you reach the armpit and groin area. Pull the pelt back to expose the layer of connective tissue around the legs. Slice through the tissue, then run a couple of fingers under it along the legs. You should be able to flip the pelt over the end of the bones where you cut off the feet.

Flip the beaver on its side and continue separating the pelt from the muscle tissue,

Pelting a raccoon (con't.)



Remove tail bone with puller.

Ohio DOW



Once the tail is free, you can use the tail splitter, or the tip of a sharp knife to split open the tail.

Ohio DOW



Pull the pelt down to the animal's shoulders. Use a rag to get a good grip.

Ohio DOW

Pelting a raccoon (con't.)



Work your fingers through the pelt at the armpit and pull the skin off the leg.

Ohio DOW



Pull the skin down to the ankle and cut the pelt.

Ohio DOW



Pull the pelt down over the neck. Cut through the ear cartilage at the skull without cutting the fur.

Ohio DOW

working toward the backbone. You'll probably need to cut into the muscle tissue near the lower hip and tail, leaving some of it attached to the pelt. The middle part of the pelt will separate easily by pulling it back or running your hand between the pelt and muscle. Don't worry about skinning out the shoulders and neck at this point. Lay the beaver on its back and repeat these procedures on the other side.

After the pelt is loose on both sides, lay the beaver on its belly and flip the pelt over the beaver's head. This exposes the shoulders, which can be separated easily from the pelt. Continue working toward the head until you encounter the ear canals at the base of the skull – they are somewhat bony and connected by cartilage. Cut through the cartilage at the skull and continue skinning out the head. You'll need to make some cuts to separate the connective tissue around the eyes and another when you get to the tip of the nose.

Fleshing pelts

Fleshing removes fat and muscle tissue that can spoil and damage the pelt. Muskrats, mink, weasels, foxes, coyotes and bobcats are relatively easy to flesh. Raccoons, beavers, badgers and skunks are more difficult.

Muskrats

For muskrats, you'll need a fleshing board and a scraper. You can make a fleshing board from a piece of 1 x 6-inch lumber. Cut it to the shape of a wire stretcher, but not as wide. Use a rasp to round the edges, and then sand them smooth.

Turn the pelt so that the leather side faces out and pull it over the rounded tip of the fleshing board. Rotate the pelt until the sides are on the flat working surfaces (one of the holes from a front leg should be on the front, the other on the back). Pull the pelt downward until it's snug.

Using a one-handed scraper, serving spoon or dull knife, remove any chunks of fat or muscle from the skirt (bottom) of the pelt. Next, remove any muscle tissue attached to the pelt near the cheeks. Well-fed muskrats have a fat deposit under each armpit. Remove these along with the reddish membrane that covers them.

Over-scraping is usually more of a problem than under-scraping with muskrats. If you apply too much pressure, you'll tear a hole in the pelt. Small specks of fat aren't a problem because they'll dry out when you put the pelt on a stretcher. It's the larger chunks and



deposits under the armpits that need attention.

Mink and weasels

Place the pelt leather-side-out on a wooden stretcher. Use a narrow stretcher for females, which are smaller than males. Remove any muscle or chunks of fat along the skirt (bottom) of the pelt with a dull knife or one-handed scraper. Avoid getting fat or grease on the fur side of the pelt. If you do, rub the fur with sawdust to remove it.

Wild mink usually have a fat deposit under each armpit. Remove it along with the thin membrane that covers it. Be careful not to cut or rip the front legs.

You'll notice a thick red membrane across the lower back (below the shoulders). This is called a "saddle." Leave the saddle attached to the pelt unless it has a thick deposit of fat under it, which is rare with wild mink or weasels.

Foxes, coyotes, and bobcats

Remove all burrs by combing the fur. Nicking one with your fleshing knife while working on the leather side of the pelt can cause it to tear.

For the most part, foxes and coyotes require little fleshing. Remove any muscle tissue and chunks of fat. This is usually easier with a two-handed fleshing knife than a one-handed scraper. The cartilage at the bases of the ears should be cut off with a regular knife to avoid spoilage.

Raccoons, beavers, skunks and badgers

These pelts are the most difficult to flesh. The skin is covered by a thin layer of fatty material. This layer is covered by a membrane. You must remove both the membrane and the fatty layer for the skin to dry properly. We recommend spending time with a fur buyer or someone else with experience before trying to flesh these species yourself.

You'll need a fleshing beam, plastic apron and two-handed fleshing knife.

The belly is the easiest place to start. Starting at the head, use the dull edge to remove the membrane and underlying fat. Work it off as far as you can reach comfortably then rotate the skin enough to work on the next section. Be careful around the front legs because you can cut or rip through creases or folds of loose skin.

Pelting a raccoon (con't.)



Pull the pelt down to the eyes. Work your knife around the eyelids without cutting the fur.

Ohio DOW

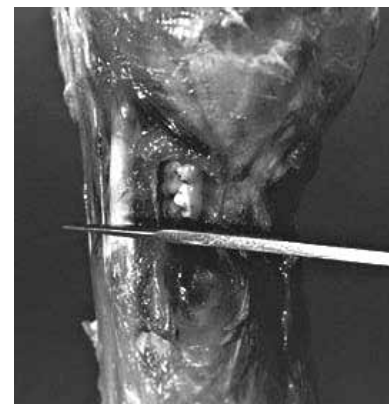

Cut the pelt free at the jaw hinge, and then follow the lips without hitting the teeth. The teeth will dull your knife.

Ohio DOW



Cut through the bottom of the lip and free the pelt. You don't need to skin all the lower jaw. Cut lip half way up.

Ohio DOW

Fleshing a raccoon



Raccoons have a lot of fat. Work the pelt over the fleshing beam. Put a rag over the nose of the pelt and press your stomach against the beam to hold the pelt. Start scraping just behind the ears, working down the pelt and away from your body using a pushing motion.

Ohio DOW



Pull the pelt up on the beam as you work further down the skin. This picture shows the fleshing knife working the raccoon's stomach area.

Ohio DOW

Starting behind the ears, use the sharp side of your knife to slice through the membrane on the neck. Let the blade of your fleshing knife ride under the membrane and push it away from you.

When the part of the pelt nearest you is fleshed all the way around, pull the pelt toward you and use your waist to pin it to the end of the fleshing beam. Continue fleshing all the way to the skirt (bottom) of the pelt. The edge of the skirt should be fleshed clean. The tail should be fleshed if it's fatty.

Fleshing beaver is similar except that most people prefer to start behind the ears and work all the way to the tail end of the pelt using the sharp edge of their fleshing knife. After a strip as wide as the shoulders is completed, rotate the pelt and work the fat and membrane off the sides with the dull edge of your fleshing knife. Be careful around the leg holes because it's easy to tear them.

Stretching and drying

Muskrats

Most people prefer to use wire stretchers for muskrat pelts. Place the pelt on the stretcher with the fur side in. Adjust the pelt so that the eyes and ears are centered on one side and the front leg holes are centered on the other. Poke a small hole through the pelt at a point where the center of the tail would have been attached. Insert the middle tooth of one hook and pull it downward to remove any slack from the pelt. Attach the other hook to the belly with two teeth and remove any slack.

Hang stretchers from a rafter to keep them away from mice while drying. Temperatures between 40 and 60 degrees are best for drying pelts. Use a fan if the humidity is high.

NOTE: Never try to make a pelt bigger than it is by "stretching" it. Pelts should be pulled tight enough to take the slack out of them – no more, no less.

Mink

Use wooden stretchers for mink. They come in two sizes. Narrow boards are used for females, which are usually smaller than males. Unusually small males can be put on a female board if the pelt looks too short and wide on a male board.

Place the pelt on the stretcher with the fur side in. Adjust the pelt so that the eyes and

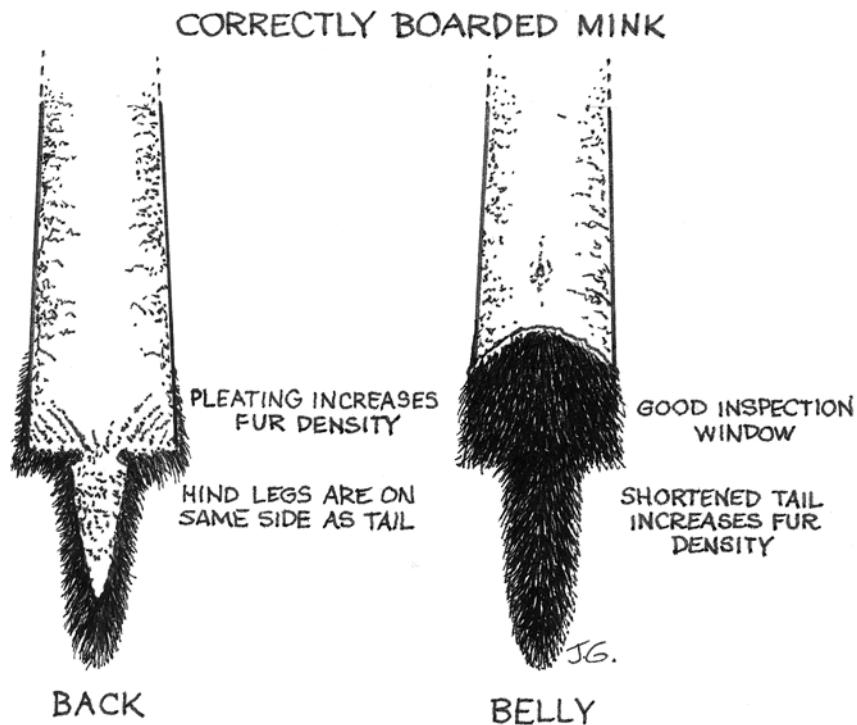

ears are centered on one side and the front leg holes are centered on the other. Grab the tail with one hand and use your other hand to stroke the pelt downward from head to tail. This removes slack without overstretching.

Pull up and out on the tail. This helps to move part of the underside to the back of the stretcher and creates an inspection window without cutting. Lay the tail back on the board. Pull down slightly if the pelt has any slack in it.

Tack the base of the tail to the board using an aluminum push pin. Bunch up the pelt on both sides of the push pin until the ends of the back legs come around to the same side of the board as the tail. Tack them at the edges of the board. Now tack the skin between the tail and the ends of the hind legs. It should be bunched slightly between each pin to make a pleat.

Spread the tail. Beginning at the butt end, push it upward toward the skirt in small increments. You want to make it short and wide instead of long and narrow. Pin the sides of the tail or place a piece of galvanized hardware cloth over the tail and pin it to the board.

Cut off the lower lip. Trim the front legs to about 3/4" in length and poke them back

Fleshing a raccoon (con't.)



When you finish fleshing the body, do each leg and the tail. Be careful around the tail so you don't tear it off. Ohio DOW



Slip the pelt over the wire stretcher and adjust it. Fasten the tail and rear legs. Ohio DOW



Illinois Department
of Natural Resources

Opening cuts for a fox or coyote.

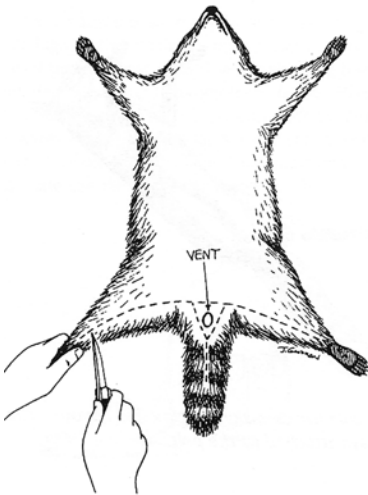

Opening cuts for a raccoon.



Opening cuts for a
muskrat.

Illinois Department
of Natural Resources

between the pelt and the board. Place a “belly board” (a narrow wooden wedge) between the board and the fur side of the pelt on the belly. The pelt will shrink as it dries. If you don’t use a belly board, it can shrink so tightly to the board that it’s difficult to remove when the time comes.

Raccoons

Use wooden or wire stretchers for raccoons. Wire stretchers are cheaper than wooden ones. They also save time because the pelt is attached by two hooks instead of tacked along the skirt. The advantage of wooden stretchers is that they give you more control over the shape of the pelt. This makes for more uniform pelts and, on average, higher prices in some markets.

When using a wire stretcher, squeeze the two sides together and slip the pelt over the top. Release the sides and square the pelt on the stretcher so that the eyes are centered on one side and the front legs are centered on the other. Pull the pelt down snugly and fasten a hook to the tail (about 2-3 inches below the base) using one or two teeth. Use the other hook to fasten the tips of the hind legs on the belly side. Pull down on both hooks to remove any slack from the pelt. Cut off the lower lip, and then trim the front legs to a length of about 3 inches.

Some people enlarge the inspection window on the belly by trimming away some of the pelt that bunches up in the groin area. This gives a neater appearance without hurting the pelt because the thin, kinky hair on the lower belly has no value.

When using a wooden stretcher, slip the pelt over the end and adjust it so that the eyes are centered on one side and the legs on the other. Pull downward gently to remove any slack from the pelt. Tack it at the base of the tail using an aluminum push pin. Bunch up the pelt on both sides of the push pin until the ends of the back legs come around to the same side of the board as the tail. Tack the ends at the edges of the board. Now tack the skin between the tail and the ends of the hind legs. It should be bunched slightly between each pin to make a pleat.

Spread the tail. Beginning at the butt end, push it upward toward the skirt in small increments. You want to make it short and wide instead of long and narrow. Place a piece of galvanized hardware cloth or cardboard over the tail to hold it in place, then pin the hardware cloth to the board.

CORRECTLY BOARDED
RACCOON

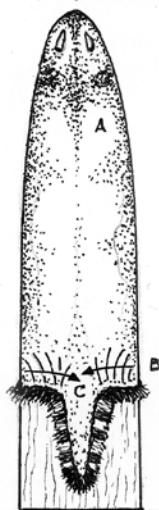

- A. SKIN IS TACKED TOWARD CENTER
- B. TAIL IS PUSHED UPWARD
- C. MAXIMUM LENGTH PLUS MAXIMUM DENSITY IN INSPECTION AREA

POORLY BOARDED
RACCOON

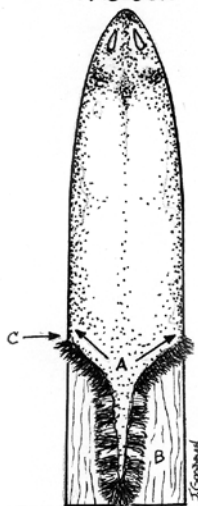

- A. SKIN IS PULLED AWAY FROM INSPECTION AREA, WEAKENING THE FUR
- B. TAIL IS PULLED TOO TIGHT, TAKING FUR DENSITY FROM INSPECTION AREA
- C. LENGTH IS LOST FROM NOT BRINGING THE EDGES DOWN TO THE BASE OF THE TAIL



Chris Tischeafer

North American Fur Auctions produced five instructional fur handling videos. Contact your state instructor to view these professional fur handling videos.

Cut off the lower lip. Trim the front legs to about 3 inches in length. Place a “belly board” (a narrow wooden wedge) between the board and the fur side of the pelt on the belly. The pelt will shrink as it dries. If you don’t use a belly board, it can shrink so tightly to the board that it’s difficult to remove when the time comes.

Beavers

Beaver pelts are stretched open on a piece of plywood. The correct shape is oval. Ask a fur buyer or auction house for a pattern that can be traced directly onto your stretching boards.

Spread the pelt on the board, fur side down. Choose a pattern that best fits its size. As a rule of thumb, you’ll lose 3-4 inches in length when you tack the sides. Tack the nose, butt and middle of both sides with 4d (4-penny finishing) nails. Next, tack the pelt between each of these nails. If the pelt seems too tight, pull the nails and begin again on the next smallest pattern.

Tack the pelt every 1/2-3/4 inches. Trim any fat or gristle from the edges of the leg holes and nail them closed. Trim the lower lips to give a nice even curve to the top of the pelt. Using a screwdriver, lift the edges of the pelt away from the board so that the pelt dries evenly.



Ohio DOW

Wedge – When using wooden stretchers use tacks to hold the tail and feet in place. Use a wedge between the belly and the board so that you will be able to remove the pelt when it dries and shrinks.

How do you plan on disposing of the unused portion of the animal carcasses? Plan ahead and dispose of properly.

Skunk Deodorizer – this mixture will help neutralize the odor of skunk on pelts, pets, clothing, or equipment. Mix 1 tablespoon dish soap, 1 pint hydrogen peroxide, and 1 cup baking soda in a container. Soak affected area with solution (keep away from eyes). Rinse and re-apply as necessary. Single use only – do not cover or cap container.

Foxes, coyotes and bobcats

You can purchase solid wooden stretchers or adjustable wooden frames. Remember to use a belly board for solid wooden stretchers. Do not cut an inspection window in foxes or coyotes.

When using a wood stretcher, position and fasten the pelt with the fur side in, much like a raccoon. Trim off the lower lip with a knife. If necessary, trim the front legs to a length no longer than 2 inches.

Allow the pelt to dry until the skin side is no longer tacky (4-12 hours depending on the temperature and humidity). Remove the pelt from the stretcher. Turn it inside out (with the fur facing out). If dry, the front legs can remain inside the pelt when it's turned. NOTE: If a pelt is too dry to turn easily, wrap it with a warm, damp towel for a few minutes and try again.

Place the pelt back on the stretcher and fasten it. Reinsert a belly board to prop the pelt open so that air can circulate. Allow the pelt to dry completely before removing it.

Summary of fur handling techniques

Species	Skinning Method	Tail	Fur Side	Stretcher Size (Wire)	Fleshing and Stretching
Muskrat	Cased	Off	In	#1	Don't overflesh
Mink (male)	Cased	On	In	Not recommended	See boarding instructions
Mink (female)	Cased	On	In	Not recommended	See boarding instructions
Raccoon	Cased	On	In	Not recommended	Flesh through membrane
Skunk	Cased	On	In	Not recommended	Flesh through membrane
Weasel	Cased	On	In	Not recommended	Little or no fleshing required
Fox	Cased	On	Out	Not recommended	Turn pelt fur side out when skin is dry to the touch
Coyote	Cased	On	Out	Not recommended	Turn pelt fur side out when skin is dry to the touch
Bobcat	Cased	On	Out	Not recommended	Turn pelt fur side out when skin is dry to the touch
Beaver	Open	Off	NA	NA	Boards are better; correct shape is oval
Badger	Open	On	NA	NA	Flesh through membrane



Species	Length	Width at Base	Width From Nose to Base
Mink (male)	36	4-5	1¼ @ 1½; 2 @ 2¾; 2½ @ 7; 3 @ 15; 4 @ 30
Mink (female)	30	3-4	1¼ @ 1; 1¾ @ 3; 2 @ 6; 2¼ @ 14; 2¾ @ 27
Raccoon (XL+)	48-54	9	6½ @ 11; 8½ @ 30
Raccoon (XL-)	48-54	8	5 @ 5½; 7-7½ @ 25
Badger (XL+)	48-54	9	6½ @ 11; 8½ @ 30
Badger (XL-)	48-54	8	5 @ 5½; 7-7½ @ 25
Fox (XL)	66	7	2½ @ 2¼; 3 @ 3½; 4 @ 6; 5 @ 9; 6 @ 14; 6½ @ 18; 7 @ 35
Coyote (XL)	72	9	4 @ 3; 5½ @ 5; 6 @ 7½; 6¾ @ 12; 7¼ @ 17; 9 @ 39
Bobcat (XL)	72	9	4 @ 3; 5½ @ 5; 6 @ 7½; 6¾ @ 12; 7¼ @ 17; 9 @ 39
Weasel (XL+)	18-20	2-1/2	1 @ 1; 1¾ @ 1¾; 1½ @ 3½; 2½ @ 16
Weasel (XL-)	16-18	2	1 @ 1; 1¼ @ 1¾; 1¾ @ 2½; 1½ @ 4

XL+ = pelts graded as extra large or larger

(All measurements are in inches.)

Explain the procedure for “boarding beavers”

Beavers and sometimes badgers are skinned open rather than cased. The pelt is then either tacked onto a plywood board, or sewn onto a wooden or metal hoop frame for drying. If tacked onto a plywood board (this should be done skin side up), use nails at least two inches long. Place the nails no more than one inch apart. The pelt should be shaped to form either a circle or oval. Once the pelt is tacked in place, raise it off the board up to the head of the nails in order to allow air circulation between the pelt and board. If sewing the beaver pelt onto a hoop, make your stitches about an inch apart. Regardless of whether you tack or sew, the four leg holes on the pelt should be closed, either by nails or stitching.

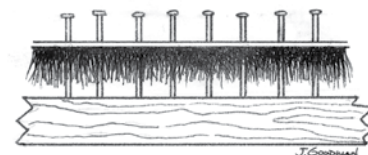

Lifting the beaver pelt will allow for faster drying.

Note: Experienced beaver trappers sometimes skin a beaver partly open, and partly cased. This makes it easier to hold the beaver on a fleshing beam. After fleshing they finish cutting the belly so they can board the beaver.

Chapter 18 – Handling Fur

Content Standard - Students demonstrate an understanding of the knowledge, skills and equipment needed to safely skin animals and prepare the pelts for market.

Explain the importance of wearing latex gloves when processing furbearers.

- Latex gloves will help protect you from animal _____.

Explain the terms “cased furs” and “open furs.”

- Except for beavers and badgers, all furbearers should be skinned _____.

Explain the terms “market fur in” and “market fur out.”

- Fur in means that the fur side of the pelt should be on the _____ when the case-skinned pelt is taken to market.

Explain why the tails of some furbearers are split and left on the pelt while the tails of others are removed.

- Furbearers with _____ tails should have their tails split open and the _____ should be removed.

Know the purpose of a fleshing beam and fleshing tools.

- Once you have skinned a furbearer, the next step is to _____ the pelt.

Describe the proper use of wire and wooden stretchers.

- A stretcher holds the pelt in place as it _____ so that it does not shrink or shrivel.

Explain the process of drying pelts and why it is important.

- If a pelt is not properly dried it can _____ and the value will be lost.

Explain the process for freezing pelts.

- Be prepared to discuss proper storage procedures for pelts.

Explain the procedure for “boarding beavers.”

- Beaver pelts are skinned open. The pelt is then _____ onto a plywood board or _____ onto a hoop frame for drying.



Content Standard – Students demonstrate an awareness of their responsibilities to landowners, wildlife, other outdoor users and the public.

Introduction

Trappers and hunters have a legal responsibility to follow regulations. Trappers and hunters have a moral obligation to make good decisions when their actions might affect wildlife, landowners, other outdoor users or the public. Ethical trappers and hunters consistently make decisions that result in the greatest good for wildlife, the environment and people.

Know that there are legal and social obligations to follow trapping regulations.

Trapping and hunting is a privilege. Society expects trappers and hunters to behave in certain ways if they want to participate. That is why we have regulations for seasons, traps, sets, permission to trap and public safety. Those who fail to follow regulations face possible fines, jail time and the loss of licenses. Illegal trappers also face disapproval from other trappers and outdoor users. If you want to be accepted by other trappers, you must know the regulations and follow them.

Know that responsible trapping involves many decisions that cannot be defined by law.

Laws cannot define what is right or wrong for you in every situation. You must use judgment based on your knowledge, skills, attitudes and experience to decide what is right or wrong. You can learn from your family or a trusted mentor. In time, you will understand how to make good decisions on your own.

Your relationships with other people, and your social acceptance as a trapper, develop as people come to know how you behave. When you behave in ways that are good for animal welfare, landowners, other outdoor users and the public, you will be an ethical trapper.

Know that ethics is a system of principles for good conduct.

Ethics is a term you should know. Many trappers, hunters and anglers discuss ethics.

Ethics is not a science. Ethics deals with right or wrong in human behavior.

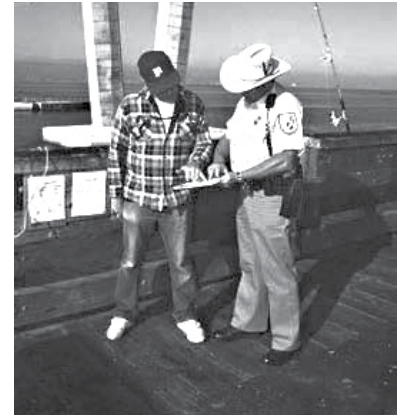

Legal Obligations

Trappers, hunters and anglers must know the regulations and follow them to help conserve resources, and to be accepted in the conservation community.

Trappers and fur hunters must always take the high road. Obeying the law is always the minimum standard of conduct.

Behave as though there is a video camera crew with you afield, with the video being shown on national television that evening. Will you be proud of what they see?



Muskrat skull.

Brent Terres

Good behavior in one situation may not be good in another. As an example, if beavers have entered an area where they are causing damage you may choose to capture as many as you can. If beavers are scarce on another property, you should capture only a few of the animals.

List specific ways trappers can demonstrate responsible behavior concerning wildlife

Animal welfare is a top concern for the general public, trappers, and other conservationists.

You should:

- Know Best Management Practices and use BMP recommended traps and sets to enhance animal welfare.
- Work to maintain or improve wildlife habitat and minimize any negative effects your trapping activity might have on vegetation or nontarget wildlife.
- Report hunting and trapping violations to authorities.
- Report suspected wildlife diseases.
- Fully use each animal.
- Cooperate with state and federal fish and wildlife management agencies.

List specific ways trappers can demonstrate responsible behavior to the public

Trappers must demonstrate respect toward all other people if they expect to be treated with respect in return. Many people do not understand that wildlife is abundant or that trapping benefits wildlife and people. Your attitudes and behavior will affect people in a positive or a negative way. You should:

- Avoid trapping near property boundaries where you do not have permission.
- Avoid making sets in areas that might capture pets.
- Be able to explain trapping as a highly regulated activity that provides positive benefits to society.
- Be a public advocate for animal welfare and wildlife management.
- Know the trapping/furbearer hunting regulations and follow them.
- Use discretion when transporting animals.

List specific ways trappers can demonstrate responsible behavior to other trappers

Trappers must cooperate with each other to ensure the continued use of trapping as an accepted wildlife management technique.

- Join state and/or national trapping organizations so you can learn from others and share your knowledge.
- Avoid areas and sets of another.



- Report illegal trapping activity – one individual's conduct affects everyone's conduct.
- Help teach new trappers.

List specific ways trappers can demonstrate responsible behavior to hunters and other outdoor users

Millions of North American citizens participate in outdoor activities. Responsible trapping is compatible with other activities at most times and places. To avoid potential conflicts with other outdoor users you should:

- Ask landowners who else might be using their property during trapping season. Communicate with them to find out when and what they might be doing.
- Avoid land trapping on public or private property when hunters may be out in numbers, especially those using dogs.
- Check traps as early in the morning as possible to remove animals that may be found by dogs or people.
- Wear hunter-orange clothing during hunting season so others can clearly identify you as a person;
- Support responsible hunting when hunters need your help.
- Be a responsible steward for all wildlife and habitats.

List ways trappers and hunters can care for and respect natural resources while pursuing and taking furbearers

Trappers and hunters should recognize positive and negative values of furbearers and habitat in the environment:

- Avoid destroying living vegetation to make sets.
- Trap or hunt in areas where furbearers are over-abundant.
- Decrease your trapping or hunting activity in areas where furbearer populations are low.
- Don't drive vehicles off the road where you may destroy natural vegetation.
- Practice low impact camping.
- Support the reintroduction of species to areas they once inhabited.

Participate in open discussions on the ethics and responsibilities associated with trapping

Group discussions are an excellent way to develop your understanding of ethics and responsibilities. Here are some topics to get you started. For each situation consider:

- What you could do.
- What you should do.
- What you would do.



A history of cooperation.

FWS

Ethics

Ethics concerns right and wrong in human behavior. Although it involves the application of human reason, it is not a science.

Definition of Responsible

- *Liable to be required to give account, as of one's actions or of the discharge of a duty or trust.*
- *Involving personal accountability or ability to act without guidance or superior authority.*



Trappers, hunters, and anglers work with resource agencies in many ways.

Trappers and hunters must demonstrate responsible behavior.

State and national trapping organizations benefit individual trappers, trappers as a group, and society by promoting conservation and responsible behavior.

Scenario 1 – Your older cousin invites you to go trapping. Along the way, you come to a fence posted with “No Trespassing” signs. As he starts to cross the fence, you ask him “Do we have permission to go there?” He responds, “The owner doesn’t care, and besides, he never comes back here; now come on, let’s go.”

Scenario 2 – It is Christmas break from school. You have put out a trap line with more than three dozen sets. One afternoon a friend calls and asks you to spend the night and go to an all-day party the next day. It sounds like fun and you really want to go.

Scenario 3 – A friend introduces you to a Mr. Smith who is complaining about problems with raccoons on his new 500-acre farm. He gives you permission to trap. On the third day of the season at a remote part of the farm you are confronted by a fox trapper who accuses you of trespassing on property where he claims sole permission to trap. You tell him you have permission from Mr. Smith, but he claims the property is owned by the Jones family, who moved to the city several years ago.

Scenario 4 – You are checking your land sets on public land where you haven’t seen anyone else since trapping season opened. Suddenly, you hear several gunshots and turn to see a group of about a dozen hunters in a wide line walking across the field in your direction. As you watch, you can hear the sound of dog bells and beepers coming closer. They are going to pass through an area where you have several foothold traps and cable devices set for coyotes.

Scenario 5 – You are trapping on private land where you know the landowner is generous about giving permission to hunters and trappers. You find a muskrat in one of your body-grip traps at a den site. A man and a young girl approach you and accuse you of stealing fur from their traps. You haven’t stolen anything, and you haven’t seen anyone else’s traps on the property since the season opened. How would you respond?

Scenario 6 – It is the second day of trapping season. Before school, you checked your traps and found several muskrats, a mink, and two raccoons. After school you return home and begin the process of skinning and fleshing your fur when three friends show up. One of them is offended to find out that you are a trapper. You don’t know what the other two think because they are unusually quiet. What would you say to your friend?

Scenario 7 – It is six weeks before the trapping season opens. You show up at a farm to do some scouting where you have permission to trap. The landowner complains about deer



damaging his crops. He comes out of the house with two rifles and says he wants to go along while you scout and have you help him kill several deer. If you turn him down, he may not let you trap on his property anymore. You know that there are too many deer in the area, but deer season is not open and the state wildlife agency is the one in charge of deer depredation.

Scenario 8 – You are out checking your fox traps on a private farm. As you approach a set, you find a fox in someone else’s trap set about 30 feet upwind of one of your dirt-hole sets. You can see well in all directions and no one else is around. You’ve worked hard to do everything right, and you feel like that fox would have been yours if the other trapper had stayed away.

Being an advocate for trapping in North Dakota

If you asked 100 strangers whether trapping was OK, most would say no. It’s not because they dislike you. It’s not because they oppose the use of animal products – nearly all of them eat meat, drink milk or wear leather shoes.

So why are they so quick to respond? More often than not, it’s because they know very little about trapping – their response is based on the belief that killing animals is wrong unless it somehow benefits society and is done responsibly. You won’t change this philosophy. In fact, you probably agree with it as strongly as anyone.

What you can change is peoples’ awareness of the benefits, oversight and responsibilities that come with trapping. People are less likely to oppose trapping if they recognize that it’s highly regulated, doesn’t endanger animals and benefits society.

Why should you care? The future of trapping depends on it. Help to maintain regulated trapping by taking every opportunity to let people know:

Trapping does not cause wildlife to become endangered

- All animals that are trapped in North Dakota are abundant.
- In North America, every endangered species is protected by laws that prohibit hunting and trapping.
- Trapping removes part of a surplus that’s produced each year – it doesn’t harm the population’s future.



Respect others who use the outdoors, such as birdwatchers.

Silvertip Productions



Millions of Americans hunt and trap.

Silvertip Productions



Silvertip Productions

Behave responsibly even when no one is watching.



Silvertip Productions

This trapper has earned the respect of landowners. As a result, he has access to thousands of acres of private land for trapping.

Trapping is highly regulated

- Regulations are enforced by trained game wardens.
- Most harvest seasons are set in the fall and winter to coincide with the time of year that pelts are most valuable.
- Regulated trapping is endorsed by trained wildlife professionals who care about the welfare of wildlife.

Trapping provides many benefits to society

- Trapping can help to keep wildlife from becoming overpopulated – especially in areas where humans have removed natural predators or altered the natural habitat.
- In many situations, trapping is necessary to reduce or prevent damage to crops and other property.
- Parts of animals that aren't used for fur clothing can be processed into soap, paint, pet foods and other items that include animal by-products.
- License fees and excise taxes on certain kinds of sporting equipment are used to manage all of North Dakota's wildlife – not just those species hunted or trapped.
- Trapping can help to keep furbearers from becoming so abundant that they harm their own environment.
- Trapping can help to reduce the potential for wildlife diseases like rabies.
- Trapping can be an important tool for saving endangered species when their populations are being affected by predators or their status can be improved by capturing animals in areas where they're common and releasing them where they're rare or absent.
- Trapping provides opportunities for outdoor activity and helps our society remain connected with our natural resources.

Tips for being an effective advocate

Begin by memorizing the main messages (those in bold). Practice them. Use them whenever the opportunity arises. Fill in the supporting messages as you gain experience.

Assume a fog, not a brick wall, when it comes to peoples' attitudes about trapping. Most will listen if you're sincere and stick to the facts. After all, you aren't trying to convince them to run out and buy a dozen traps. You're hoping they'll recognize that trapping is a necessary and appropriate activity that should be allowed to continue – even if they don't support it fully.

Join local, state and national trapping organizations to stay informed on improvements and threats to trapping. Write legislators when the need arises.



Above all, be polite and truthful.

The North Dakota Game and Fish Department recognizes that regulated fur hunting and trapping is a versatile, safe, effective, and ecologically sound means of capturing individual animals without impairing the survival of furbearer populations or damaging the environment. Trapping and hunting provides an outdoor lifestyle for many North Dakota citizens through use of an abundant natural resource and provides an effective means of harvesting, managing and/or studying furbearers; controlling damage caused by furbearers; and, at times, reduces the spread of harmful disease. The Department also recognizes that trapping concerns some segments of the public who oppose trapping, the use of specific trapping devices or consumptive use of animals.

The Department supports regulated trapping and efforts to address societal concerns through appropriate education, research, enforcement and regulatory programs. Such programs are designed to increase awareness and acceptance of trapping by seeking to enhance animal welfare while maintaining wildlife management capabilities and other benefits associated with this activity.



Trapping instructor passing it on. Silvertip Productions



Adventure awaits – be responsible! Silvertip Productions

- *What could you do?*
- *What should you do?*
- *What would you do?*

Chapter 19 – Responsible Trapping

Content Standard - Students demonstrate an awareness of their responsibilities to landowners, wildlife, other outdoor users and the public.

Know that there are legal and social obligations to follow trapping regulations.

- In most situations, trapping is considered a _____.
- Obeying the _____ is always the minimum standard of conduct.

Know that responsible trapping involves many decisions that cannot be defined by law.

- When you behave in ways that are good for animal welfare, landowners, other outdoor users and the public, you will be an _____ trapper.

Know that ethics is a system of principles for good conduct.

- Ethics involves _____ or _____ in human behavior.

List three specific ways trappers can demonstrate responsible behavior concerning wildlife.

1. _____
2. _____
3. _____

List three specific ways trappers can demonstrate responsible behavior to the public.

1. _____
2. _____
3. _____

List three specific ways trappers can demonstrate responsible behavior to other trappers.

1. _____
2. _____
3. _____

List three specific ways trappers can demonstrate responsible behavior to hunters and other outdoor users.

1. _____
2. _____
3. _____

List three ways trappers can care for and respect natural resources while pursuing and taking furbearers.

1. _____
2. _____
3. _____

Participate in open discussions on the ethics and responsibilities associated with trapping.

- Be prepared to discuss your ethical obligations and responsibilities as a trapper during class.



Tait Ronnigen
NDGFD

Bear tracks.
Front—4 inches width
 4.5 inches length
Rear—3.5 inches width
 7 inches length

American black bear

Ursus americanus; Order Carnivora; Family Ursidae

American black bears are the most abundant and widespread of the three bear species found in North America, occurring in 42 of the continental United States and 11 Canadian provinces.

Black bears measure 3-6.5 feet in length. Males usually weigh an average of 130-300 pounds, with some exceeding 600 pounds. Females are smaller, weighing about 90-150 pounds. Black and brown are the two major color phases.

General habitat requirements include relatively remote landscapes with dense vegetation and abundant food sources. Black bears are omnivorous, meaning they feed on both plants and animals. Throughout the seasons, bears eat berries, acorns, insect larvae and ants, eggs, birds, small mammals, fawns and carrion.

Females usually breed every other year, beginning when they are 3-4 years old. Breeding takes place during the summer and two to four cubs are born in winter dens. Cubs remain with their mother until they are about a year-and-a-half old.

In North Dakota, black bears occasionally are sighted in wooded habitats with water in the eastern and north central parts of the state.

Arctic fox

Alopex lagopus; Order: *Carnivora*; Family: *Canidae*

The arctic fox has a variable fur color. In summer, it is bluish brown or gray with light under-sides. In winter it is white to cream-colored. There also is a blue-phase arctic fox that lives in areas without permanent snow cover. Arctic foxes weigh 5.5-9 pounds and measure 30-36 inches with a 10-14-inch bushy tail. Females are smaller than males. The body is compact. Its legs and ears are short, and the footpads are thickly haired, all of which help it conserve heat in subzero weather.

The arctic fox is found in western and northern Alaska and Northern Canada, living in the tundra or on ice flows. It dens in hillsides or snowbanks, feeding heavily in the summer and burying food for the winter in the permafrost. Arctic foxes are opportunistic feeders, eating rodents, birds, eggs, fish, berries, young seals, carrion, and they follow polar bears and forage on remains of bear kills. Breeding occurs from February to May, resulting in one litter of 6-12 young.

Arctic fox are not found in North Dakota.

Badger

Taxidea taxus; Order: *Carnivora*; Family: *Mustelidae*

Badgers are wide, flat carnivores with a grizzled gray appearance and a distinctive white stripe from their nose, over their head and ending between their shoulders. Average adults weigh 12-16 pounds, but may increase to 20 or more pounds in the fall. Badgers are well known for their digging ability and fierce disposition. Badgers use multiple elaborate dens with tunnels from 6-15 feet deep and as much as 30 feet to an elevated main chamber. Badgers use bedding material and have a separate toilet chamber.

Badgers primarily occur in the western and north central states, with some eastward expansion. They occupy a home range of 3-4 square miles of prairie, open farmland, deserts and woods if the soil is suitable for digging. Badgers eat prairie dogs, gophers, skunks, snakes, birds, eggs, worms, insects, carrion and berries. In North Dakota, the primary source of food is ground squirrels and pocket gophers. Young badgers are eaten by coyotes and eagles. Breeding occurs in August or September with implantation delayed until February. Badgers have one litter a year with 2-7 young.

Badgers are common in North Dakota and are most abundant in the prairie regions. Although they do not spray like a skunk, badgers will release a strong musk odor from a pair of anal scent glands when disturbed. Establishing and maintaining grassland habitats are the most important conservation measures for this species.



FWS

Arctic fox tracks.
Front/Rear
2.5 inches width
2.5 inches length



Mary Wentz
 Silvertip Productions



Badger tracks.
Front—2 inches width; 1.5 inches length
Rear—1.75 inches width; 2 inches length

Mary Wentz
 Silvertip Productions



FWS



Mary Wentz
Silvertip Productions

Beaver tracks.

Front—2 inches width

2 inches length

Rear—4 inches width

6 inches length

Beaver

Castor canadensis; Order: *Rodentia*; Family: *Castoridae*

Beavers are large, bulky rodents capable of altering their habitat by building dams and lodges, but they also will den in river banks. Adults can exceed 60 pounds. The hind feet are large and fully webbed. Beavers have a distinctive, large, flat tail that can be used as a rudder or slapped loudly on the water to sound an alarm. They have sharp teeth, capable of cutting down large trees. Colors vary from blonde to black. The beaver is primarily nocturnal and both sexes have large castor glands beneath the skin on the lower belly.

Beavers range throughout most of the United States except for Florida, Nevada and southern California. Habitats include rivers, streams, marshes, lakes and ponds. Foods include tree bark, water lilies and crops. Otters, bears, lynx, bobcats, wolves and coyotes prey on beavers. In good habitat a beaver's home range will cover up to .6 mile of a stream or river. If food is scarce they may travel as far as 650 feet from the water. Beavers breed in late January or February and have one litter per year averaging 4-5 kits.

Beavers are common in North Dakota, especially along the larger streams and rivers, and are less common in the prairie pothole region. Beavers are an important part of the ecosystem because their dams create fish and wildlife habitat, reduce erosion and improve water quality. Conversely, the animal sometimes damages valuable trees and crops or causes flooding that affects farmlands, roads and residential areas.

There are two diseases that beavers that can spread to humans. Tularemia is a bacterial disease. You can get it from infected beavers by coming in contact with blood, tissue or water. Human symptoms include headache, chills, vomiting, fever, aches and pain. Giardiasis, a parasitic disease, enters the water when beavers that have the parasite defecate. It causes acute diarrhea and abdominal pain in humans. Drinking contaminated water is the most common means of transmission.

Bobcat

Lynx rufus; Order: *Carnivora*; Family: *Felidae*

Bobcats have short tails. They are colored red, brown, or gray on the back and lighter below with black spots on the front legs and bellies that fade as the animal ages. Bobcats primarily are nocturnal and normally weigh 18-22 pounds, with females on the smaller side. Large individuals have been reported weighing as much as 76 pounds. Bobcats have retractable claws that do not show up in tracks. Bobcats will wade or swim.

Bobcats range throughout most of the United States occupying dense forests, mountains, prairies, farmland, deserts and swamps, often denning in rock outcroppings. Bobcats eat rabbits, beavers, and occasionally deer. Coyotes, eagles, fishers, wolves and mountain lions kill and in some cases, prey upon bobcats. Adult male bobcats sometimes kill and eat juveniles. Breeding occurs during February and March, with one litter a year producing 1-4 young. Females breed during the first year, and males at 2 years. Females occupy a home range of about 6 square miles while males may roam over as much as 60 square miles.

In North Dakota, bobcats are common west of the Missouri River and only found occasionally in the remainder of the state. Maintaining and managing some forested habitats are important conservation measures. This includes protecting some of the more unique areas of the Badlands.

Canada lynx

Lynx canadensis; Order: *Carnivora*; Family: *Felidae*

The Canada lynx is on the U.S. Endangered Species List and classified as threatened. The animal always has been rare in the lower 48 because its primary prey, the snowshoe hare, mostly is found in Canada and Alaska. Canada lynx are light gray, with scattered brown to black hair, cinnamon colored underparts and short tails. Males are larger than females, and the animals weigh from 11-40 pounds.

Canada lynx are found in Alaska and the northern states, in parts of the Rocky Mountains and New England. They live in coniferous forests, bogs, and swamps. During the day, Canada lynx rest in cover. They climb trees and often leap down onto prey including snowshoe hares, birds and voles. They also will eat larger dead animals, and occasionally deer, caribou or sheep. They pose little threat to humans or domestic animals. Wolves and mountain lions kill and in some cases prey on Canada lynx. They breed in March or April, producing one litter of 3-4 young.



Eyewire.com



Mary Wentz
Silvertip Productions

Bobcat tracks.
Front/Rear-1.75 inches width
2 inches length



Mary Wentz
Silvertip Productions

Canada lynx tracks.
Front/Rear-3.25 inches width
3.25 inches length



Craig Bihrlé
NDGFD



Mary Wentz
Silvertip Productions

Coyote tracks.

Front–2 inches width
2.5 inches length
Rear–1.5 inches width
2 inches length



Illinois Department
of Natural Resources



Mary Wentz
Silvertip Productions

Fisher tracks.

Front/Rear–2.5 inches width
2 inches length

While not common, Canada lynx may disperse to North Dakota when prey populations, especially snowshoe hares, decline in Canada.

Coyote

Canis latrans; Order *Carnovora*; Family: *Canidae*

Coyotes are medium to large canines normally mottled with gray, but sometimes brown, reddish or black. Average weights of coyotes in the west are 25-30 pounds, but the animals are larger in the eastern United States, with some weighing as much as 60 pounds. Coyotes are intelligent and adaptable, living in a wide variety of habitats including urban and suburban areas. Coyotes are abundant and they have become less wary of humans in recent years. Attacks on people and pets have been documented.

Coyotes are widely distributed through the United States except for Hawaii. Males have a home range of 30-40 square miles, females considerably less. Opportunistic feeders, coyotes eat mice, rabbits, insects, reptiles, fawns, carrion, fruits and seeds. Adult coyotes have few predators, but juveniles are eaten by dogs, mountain lions and eagles. Breeding occurs in February in the south, and March in the north. Coyotes have one litter a year averaging 3-6 pups.

Coyotes are common throughout North Dakota. The coyotes of western North Dakota usually are somewhat smaller and lighter colored than those of the north central or northeastern parts of the state. Coyotes use a variety of barks, yips and howls to communicate. They also mark areas with urine, feces or gland secretions, much like domestic dogs.

Fisher

Martes pennanti; Order: *Carnivora*; Family: *Mustelidae*

Fishers have long slender bodies that range in color from gray brown to dark brown to nearly black with a long, tapering, bushy tail. Males weigh 7.5-12 pounds, and females 4.5-5.5 pounds. Adult males measure 35.5-47 inches in length, with females shorter at 29.5-37.5 inches. The animal has two anal scent glands that produce a foul-smelling liquid. Fishers primarily are nocturnal, traveling mostly on the ground. However, they also are agile tree climbers and sometimes swim.

Fishers are found in the northwestern United States, upper Great Lakes and New England in dense forests of conifers mixed with hardwoods near water. Nest dens are high in hollow trees, with temporary dens under logs, brush, or tree roots. Fishers travel widely with a home range of 50-150 square miles, more if food is scarce. They prey on snowshoe hares, porcupines, rodents, birds, eggs and carrion. Fishers are eaten by hawks, owls, coyotes, bobcats and black

bears. Breeding occurs in March and April with delayed implantation and birth 51 weeks after mating. Fishers have one litter a year, with 1-5 kits. Both sexes are sexually mature at one year of age.

While not common, fishers are occasionally found in northeastern and north central North Dakota.

Gray fox

Urocyon cinereoargenteus; Order: *Carnivora*; Family: *Canidae*

Gray foxes are small nocturnal canines that are more aggressive than the red fox. Gray foxes weigh 8 to 11 pounds. They are heavier in the north, and measure 31-44 inches with a 12-15-inch black-tipped tail. Fur is gray above and red on the lower sides, chest, and back. Gray foxes climb trees for food or shelter and cache their food. They are considered to be easier to trap than the red fox.

Gray foxes are found in eastern states, the southern third of western states, and along the West Coast in varied habitats with a preference for more wooded areas. They have a small home range of one square mile or less. Gray foxes use dens more than the red fox, especially in the north. Dens usually are natural cavities marked with snagged hair and scattered bones. Food includes rabbits, other small mammals, birds, insects, plants and fruit. Bobcats, domestic dogs and coyotes prey on gray foxes. Breeding occurs from January to early May, resulting in one litter averaging 3-4 pups.

While not common, gray foxes are occasionally found in wooded areas of eastern North Dakota.

Gray wolf

Canis lupus; Order: *Carnivora*; Family: *Canidae*

The gray wolf is the largest wild canine, reaching adult weights of 57-130 pounds. It is on the U. S. Endangered Species List except for Alaska, where the animal can be hunted and trapped. Colors range from white to black. Wolves carry their tails straight out, while the smaller coyote holds the tail at a downward angle. Domestic dogs' tails curve up.

The gray wolf is found in Alaska, Washington, Idaho, Montana, Minnesota, Wyoming and a few other areas, where they prefer forests or open tundra. They live and hunt in packs of 2-15 members that range up to 260 square miles. Gray wolves normally eat about four pounds of food a day, but can go long periods between meals. They hunt at night feeding on moose,



FWS



Gray fox tracks.
Front/Rear—1 inch width
1.5 inch length

Mary Wentz
Silvertip Productions

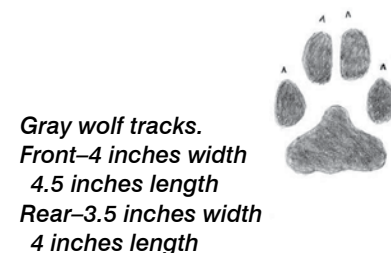

Gray wolf tracks.
Front—4 inches width
4.5 inches length
Rear—3.5 inches width
4 inches length

Mary Wentz
Silvertip Productions



Mary Wentz
Silvertip Productions

Kit fox/swift fox tracks.
Front/Rear—1.25 inch width
1.25 inch length



Dorothy Fecke



Mary Wentz
Silvertip Productions

Marten tracks.
Front/Rear—1.5 inch width
1.5 inch length

caribou, deer, berries, birds, fish and insects. Gray wolves seldom use dens, except for maternity dens. Wolves are sexually mature at two years, breed during late January to February, and produce one litter a year averaging 5-6 pups.

While not common, a few dispersing wolves travel throughout North Dakota from adjacent states or provinces in search of new territory.

Kit fox

Vulpes macrotis; Order: *Carnivora*; Family: *Canidae*

The kit fox is a small, long-legged canine with large ears. It is yellowish above and lighter below with a prominent black-tipped tail, and weighs 3-5 pounds. It is 24-31 inches in length, with a 9-12-inch tail.

Kit foxes are found in arid grassland regions of Oregon, California, Idaho, Nevada, Utah, New Mexico, Arizona, Texas and Colorado. Kit foxes eat rodents and rabbits. The San Joaquin kit fox is an endangered subspecies due to the destruction or alteration of the grasslands where it lives. Kit foxes breed from January to February, producing one litter of 3-5 young a year.

Kit foxes are not found in North Dakota.

Marten

Martes americana; Order: *Carnivora*; Family: *Mustelidae*

American martens are small weasel-like woodland mammals varying from light to dark brown with a bushy tail and orange throat. They weigh from 1-3.5 pounds, with males larger than females. Martens are active in the early morning, late afternoon, at night and on cloudy days. They can climb trees, but spend most of their time on the ground foraging for rodents. Their large feet allow them to walk on snow. Martens sometimes bury meat and both sexes establish scent posts.

Martens range from New England to the northern Great Lakes states, the Rocky Mountains and the northern West Coast, living in coniferous forests with numerous dead trees and debris. Their home range is as small as one square mile but the range varies with sex, food availability, and habitat. Martens den in hollow trees, fallen logs, rocks, squirrel nests, and woodpecker holes. Food includes red-backed voles, other rodents, red squirrels and birds. Fishers and owls prey on martens. Breeding occurs in July with delayed implantation. They have one litter a year with 1-6 young. Both sexes breed during their second year of life.

While not common, martens may be found in the heavily wooded areas of north central North Dakota.



Mink

Mustela vison; Order: *Carnivora*; Family: *Mustelidae*

Mink are small nocturnal carnivores with short dense fur shaded chocolate to nearly black with small patches of white on the chin, throat or belly. Some have light fur and they are known as cotton mink. Males measure 20-30 inches with weights over 3 pounds, while females are smaller at 16-21 inches and 1.5-2 pounds. Mink have glands in the anal area that can release a powerful, unpleasant smelling musk. They are quick on land, skilled swimmers and capable tree climbers.

Mink are widely distributed across the United States except for the Southwest and Florida. They inhabit streams, rivers, marshes, lakes and ponds. Males range widely over routes of 25 miles or more, while females stay close to their dens in holes, hollow logs, rock piles, beaver lodges, muskrat lodges or abandoned muskrat dens. Males maintain numerous dens and often cache food in some of them. They eat muskrats, crayfish, frogs, fish, rabbits, birds, insects and snakes. Owls, fox, coyotes, bobcats and dogs prey on mink. Breeding occurs in late February or early March with delayed implantation. They have one litter a year with an average of four young.

Mink are common in North Dakota. Maintaining and improving habitat are the most important conservation measures. The mink has benefited from programs that involve planting and maintaining grass and trees along streams and rivers. Some other practices that benefit this species include conservation tillage, managing grazing, wetland restoration and regulations that protect water quality.

Mountain lion

Puma concolor; Order *Carnivora*; Family *Felidae*

Mountain lions are solitary, nocturnal carnivores found mainly in the western United States. They measure 6-8 feet long from the nose to the tip of the tail, and have a tawny-colored body with a lighter underbelly, a long, black-tipped tail, and black-tipped ears. Male lions usually weigh 120-180 pounds, and females weigh 80-110 pounds. Mountain lion kittens have dark facial markings and are heavily spotted; spotting fades as the animals age.

Mountain lions feed mainly on deer and elk, but smaller prey, like porcupines and rabbits, can be important to young lions developing hunting skills and to nourish adults between kills of larger prey. Lions are ambush hunters. After prey is spotted, a lion will sneak up behind the animal using available cover (i.e., dense thickets, roots and logs of downed trees, rock piles, etc.). It attacks with a rush of speed and kills with a powerful bite below the base of the skull, break-



Craig Bihrlé
NDGFD



Mary Wentz
Silvertip Productions

Mink tracks.
Front/Rear—1.5 inch width
1.25 inch length





Sarah Neigum
NDGFD

Mountain lion tracks.
Front—3.5 inches width
3 inches length
Rear—3 inches width
3 inches length



FWS



Mary Wentz
Silvertip Productions

Muskrat tracks.
Front—1 inch width
1 inch length
Rear—1 inch width
2.5 inches length

ing the neck of its victim. Lions often drag their kills to a concealed place to feed, and bury their kills with dirt, leaves, or snow between feedings.

Throughout the western United States, mountain lion habitat is characterized by vast areas of rugged country with dense vegetation. Lions need vegetative cover and topography (rock outcrops, boulder piles, steep slopes) to successfully stalk and ambush their prey, and provide security while feeding, resting and caring for young.

Individual lions have territories varying in size from 50 to more than 300 square miles. Females with young kittens use the smallest areas, and adult males use the largest. Adult male mountain lions actively defend their territories from intruding males, which often results in the death of one of the animals. Males mark territory boundaries with piles of dirt and twigs, called scrapes, signaling to other lions that the area is occupied. Breeding takes place throughout the year. Females typically have litters of 2-4 kittens about every other year and raise the kittens without the help of the male. Young disperse when they are 13-18 months old. Females typically remain near where they were born, but males sometimes wander hundreds of miles before establishing their own territories.

In North Dakota, a small number of mountain lions are found in the Badlands region in the western part of the state.

Muskrat

Ondatra zibethica; Order: Rodentia; Family: Cricetidae

Muskrats are small rodents with dense glossy brown fur and a hairless tail, weighing 1-2 pounds in the south and 3-4 pounds in the north. Total length varies from 19-25 inches. Musk-rats are nocturnal and can swim forward and backward with the aid of partially-webbed hind feet. Males have prominent musk glands beneath the skin on their lower abdomen that swell in the spring and produce a yellowish musky-smelling fluid.

Muskrats are found throughout most of North America except for the arctic, most of California, Texas, Florida, and the Southwest. Habitats include marshes, lakes, ponds, streams, and ditches where they feed on aquatic plants such as cattails, rushes and water lilies. Mink, foxes, coyotes, hawks and owls eat muskrats. Musk-rats burrow into banks of streams and ponds, and they build prominent lodges out of cattails or other vegetation in marshes and lakes. They have a small home ranges, seldom traveling more than 200 feet from their den. Breeding occurs from late winter to September in the north, and year-round in the south, producing 1-5 litters a year and 1-11 young per litter. Musk-rats are sexually mature at six months of age.

Muskrats are common in North Dakota, especially where there is permanent water available. Maintaining and improving habitat are the most important conservation measures. Muskrats have benefited from programs that involve planting and maintaining grass and trees along streams and rivers. Some other practices that benefit this species include conservation tillage, managed grazing, wetland restoration and regulations that protect water quality.

Nutria

Myocastor coypus; Order: Rodentia; Family: Myocastoridae

Nutria are large rodents introduced to the United States from South America that create habitat problems in some areas. They have a negative impact on muskrats, waterfowl, and other native wildlife. Nutria weigh 5-25 pounds and measure up to 24 inches with a long, scaly, rounded tail that stretches another 12-17 inches. Males are larger than females.

Nutria are found in scattered locations including Texas, Louisiana, Mississippi, Alabama, Georgia, Florida, North Carolina, Virginia, Washington and Oregon where they occupy marshes, lakes, ponds, and streams. Dominant males share a den with 2 or 3 females and the young. Den entrances are 12-24 inches below the water and as much as 24 inches in diameter. The inner chamber is above the waterline and lined with grasses. The home range usually includes about 1,000 feet of habitat along a dike or shoreline. Nutria eat most any green plant and grains. Alligators, hawks, owls and eagles prey on nutria. Breeding occurs throughout the year with 1-11 young per litter. Sexual maturity is at 5-6 months.

Nutria are not found in North Dakota.

Opossum

Didelphius virginiana; Order: Didelphimordia; Family: Didelphidae

Opossums are the only marsupial (mammals in which the females have a pouch) in North America. They have a fur-lined pouch, and a prehensile, flesh-colored or whitish tail. The fur is grayish-white. Males average 6-7 pounds, up to 14 pounds, while females are smaller. Total lengths range up to 36 inches. Opossums are nocturnal and known for the habit of “playing dead” when threatened. They are strong climbers and swimmers.

Originally opossums were restricted to the southeastern United States, but spread widely due to human activity after European settlement. They are now found throughout the eastern United States and on the West Coast. Habitats include deciduous woodlands near water, but they also are suburban pests. Opossums make leaf nests in hollow logs, fallen trees, or abandoned burrows. Home ranges are small from 10-200 acres. Opossums are omnivorous, eating nearly



FWS

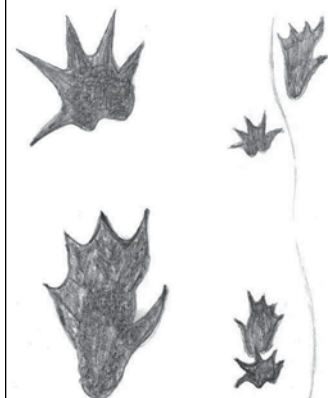

Mary Wentz
Silvertip Productions

Nutria tracks.
Front—1 inch width
1.5 inch length
Rear—1.5 inch width
3.5 inch length



any plant, animal, insect or carrion. Coyotes, foxes, raccoons, bobcats, eagles, snakes, hawks and owls prey on opossums. Most breeding occurs in February and litters have 5-13 young, which stay in the pouch for 60 days. Opossums are sexually mature at 6-8 months.

Opossums are not common in North Dakota, although they occasionally are found in the southeastern part of the state.

Raccoon

Procyon lotor; Order: Carnivora; Family: Procyonidae

Raccoons are medium-sized adaptable furbearers with a masked face and ringed tail. Average weights are 9-20 pounds, but they are larger in the north where weights up to 62 pounds have been reported. Fur color varies from dirty blonde with darker guard hairs to reddish and darker colors. The hind legs are longer than the front ones, creating a hunched appearance when running.

Raccoons are widely distributed across the United States where they use varied habitats from streams, rivers, lakes and wetlands to forests, prairies, farmland and urban areas. Home ranges vary by habitat from 15 acres in urban environments to 12,000 acres in prairies. Raccoons den in hollow trees, ground burrows, brush piles, muskrat houses, barns, buildings, clumps of cattails, haystacks, and rock crevices. They are omnivores, eating fish, crayfish, mussels, fruits, grains, small animals, birds and muskrats. Coyotes, bobcats, mountain lions, owls, eagles and fishers prey on raccoons. Breeding occurs in January in the north to March in the south. Litters average 2-5 young, up to 8. Females breed their first year, males at two years of age.

Raccoon are common throughout North Dakota.



Mary Wentz
Silvertip Productions

Opossum tracks.
Front—1.5 inch width
1.5 inch length
Rear—1.5 inch width
2 inches length



Mary Wentz
Silvertip Productions

Raccoon tracks.
Front—1.5 inch length
2 inches width
Rear—1.5 inch width
3 inches length



Red fox

Vulpes vulpes; Order: *Carnivora*; Family: *Canidae*

Red foxes are small, shy, and adaptable with a capacity for learning from experience. They weigh 10-12 pounds, but are heavier in the north, where they weigh up to 14 pounds. Lengths range from 35-41 inches with a 14-17 inch bushy tail tipped in white. Commonly red on top, gray to white lower, with black on the ears, lower legs and feet. Other color phases include black, silver, and crosses between red and silver. Red foxes primarily are nocturnal and have the ability to hear low frequencies that let them detect small prey underground.

Red foxes are widely distributed across the United States except for parts of the West. Habitats include mixed cultivated fields, woodlots, and brushland. The home range is generally 2-3 square miles, but varies with habitat and prey. Red foxes eat small mammals, birds, insects, crayfish, corn, berries, acorns and other vegetation. Coyotes are known to kill red foxes, and trappers often note lower red fox populations when coyote numbers are high. Red foxes use maternity dens to raise their young. The dens often are old woodchuck or badger diggings on slopes with good visibility. Breeding occurs in January to early March, resulting in one litter of 1-10 kits.

Red foxes are common throughout North Dakota.

Ringtail/Bassarisk

Bassariscus astutus; Order: *Carnivora*; Family: *Procyonidae*

Ringtails have cat-like bodies and long, bushy tails with 14-16 distinct bands of black and white. They weigh 2-2.5 pounds. Some people call them “miner’s cats” because they were once used in mines to control rats. During the day they stay in dens. They can climb trees or walls, and they are excellent leapers.

The ringtail’s range includes southwestern Oregon, California, Nevada, Utah, Colorado, Kansas, Arizona, New Mexico, Oklahoma and Texas. They live in rocky areas, or sometimes wooded areas with hollow trees. A varied diet includes insects, snakes, lizards, toads, frogs, birds, small mammals, carrion and fruit. They breed in April producing one litter of 2-4 young.

Ringtails are not found in North Dakota.



Craig Bihrie
NDGFD



Mary Wentz
Silvertip Productions

Red fox tracks.
Front—2 inches width
2.5 inches length
Rear—2 inches width
2 inches length



Texas Parks and Wildlife Photo



Mary Wentz
Silvertip Productions

Ringtail tracks.
Front/Rear—1.5 inch width
2 inches length



FWS

River otter

Lontra canadensis; Order: *Carnivora*; Family: *Mustelidae*

Otters are long, slender, short-haired furbearers known to be playful and intelligent. The fur is a rich, glossy, shade of brown and lighter on the cheeks, throat and belly. Males grow to 48 inches and 25 pounds while females are 4-6 inches shorter and weigh 19 pounds or less. Both sexes have anal musk glands that release when the animal is frightened. The musk is less pungent than other mustelids. Otters have webbed toes and nonretractable claws. Also, they have valves in their nose and ears that close when they are underwater.



Mary Wentz
Silvertip Productions

River otter tracks.
Front/Rear—2.25 inches width
2 inches length

Otters range over Alaska, the Pacific Northwest, Great Lakes states, the Mississippi River Valley, to the Atlantic and Gulf Coastal states. They inhabit remote rivers, lakes, wetlands and beaver ponds eating fish, frogs, crayfish, mollusks, beavers, muskrats and vegetation. Adult otters rarely are killed by other animals, with some predation by lynx, wolves, bobcats and coyotes. The home range varies from 450-14,000 acres or 5-50 linear miles of shoreline. Otters infrequently use dens but may occupy old beaver dens and lodges. Otters mate at 2 years of age. Breeding occurs in March and April resulting in one litter a year of 2-3 young.

River otters and river otter sign (scat and slides) are becoming more common throughout the Missouri and Red river systems in North Dakota.



Craig Bihrie
NDGFD

Striped skunk

Mephitis mephitis; Order: *Carnivora*; Family: *Mustelidae*

Striped skunks are small, heavy-bodied, black animals with two white stripes on the back that meet and form a white cap on the head. Skunks measure 20-30 inches and weigh 3.5-10 pounds. They are well known for their ability to spray a strong smelling, yellowish, oily fluid for protection. Primarily nocturnal, skunks have poor eyesight, keen hearing and a strong sense of smell. Skunks are capable of swimming, but they are poor climbers.



Mary Wentz
Silvertip Productions

Skunk tracks.
Front—1 inch width
1 inch length
Rear—1 inch width
1.5 inch length

Striped skunks are widespread across North America where they inhabit open fields, farms near water, urban and suburban areas. The home range is small, generally less than one square mile in size. Skunks are omnivores, eating insects, rodents, eggs, carrion and vegetation. Owls, coyotes, bobcats, foxes, badgers, lynx, fishers, golden eagles and mountain lions will prey on skunks. Skunks use dens abandoned by other animals, or hollow logs, and may use communal dens with other animals. Breeding occurs from February to April producing one litter of 2-10 young per year. They are sexually mature at 8-9 months of age.

Striped skunks are common throughout North Dakota.

Swift fox

Vulpes velox; Order: Carnivora; Family: Canidae

The swift fox is similar to the kit fox but lives in prairies east of the Rocky Mountains. The swift fox has longer ears with bases closer to the center of the skull, a more rounded and dog-like head, and a tail that is shorter than the kit fox in relation to body length. The swift fox is primarily nocturnal. Populations have declined due to conversion of prairies to croplands, overgrazing and poisoning.

While not common, dispersing swift foxes travel through North Dakota in search of new territories.

Weasel

Mustela frenata, *Mustela erminea*; Order: Carnivora; Family: Mustelidae

Weasels are small furbearers with short fur, generally light brown above and cream-colored on the throat and belly, with black-tipped tails. In northern areas their coats change to white in the winter, and these are called ermine. Adult long-tailed weasels (*M. frenata*) measure 13-17 inches including a 4.5-6.5-inch tail. Males are larger than females. Short-tailed weasels have tails 4 inches long or less. Weasels primarily are nocturnal.

Long-tailed weasels are widely distributed in the United States, except for the Southwest, while short-tailed weasels are in most of the far northern states. Habitats include mountains, farmland, forests, and prairies near water. Weasels generally stay within a half-mile of their den. They eat mice, voles, chipmunks, rabbits, birds, eggs and poultry. They are eaten by fox, mink, coyotes, bobcats, hawks and owls. Both sexes use a single den in hollow stumps, tree roots, rock piles or under old buildings. Dens are lined with grasses and fur from prey animals. Weasels breed in July with delayed implantation, producing one litter with an average of six young. Females mate at 3-4 months, males during their second year of life.

The three species of weasel are common in North Dakota. Long-tailed weasels are the most common and occur throughout the state. Short-tailed and least weasels typically occur in the prairie pothole region.



Wyoming Game and Fish



Mary Wentz
Silvertip Productions

Kit fox/swift fox tracks.
Front/Rear—1.25 inches width
1.25 inches length



Craig Bihrie
NDGFD



Mary Wentz
Silvertip Productions

Weasel tracks.
Front/Rear—.5 inch width
.75 inch length



Wolverine

Gulo luscus; Order: *Carnivora*; Family: *Mulstelidae*

Wolverines are the largest terrestrial member of the weasel family, resembling a small bear, but moving and behaving like weasels. Their fur is thick, glossy and dark brown, sometimes with a light face mask. A stripe runs from the shoulders, down the sides, and over the rump. They have a bushy tail. Males grow to 44 inches and 40 pounds, while females are about 25 percent smaller. They can release musk from their anal glands.

Wolverines are found in Alaska, Canada, and parts of Idaho, Montana, Washington and Oregon, where they inhabit boreal forests and tundra. They feed on rodents and scavenge for food including deer, caribou and moose, but they also raid traps and cabins. Wolverine tracks cover a large home range of 1,000 square miles or more. They travel with a slow lope, but they can swim and they are quick climbers. Mating occurs from April to September, but implantation is delayed until winter, producing one litter of 2-5 young.

Wolverines are not found in North Dakota.



Mary Wentz
Silvertip Productions

Wolverine tracks.

Front—4 inches width

5 inches length

Rear—4 inches width

3 inches length

Chapter 20 – Furbearers

Identify the furbearers in the following pictures. Under each, list the type(s) of habitat where the animal may be found and a major type of food that it eats.



FWS

Animal: _____

Habitat: _____

Type of Food: _____



NPS Photo

Animal: _____

Habitat: _____

Type of Food: _____



Eyewire.com

Animal: _____

Habitat: _____

Type of Food: _____



U.S. Fish and Wildlife Service Photo

Animal: _____

Habitat: _____

Type of Food: _____



Erwin C. Nielsen/Painet Inc.

Animal: _____

Habitat: _____

Type of Food: _____



USGS Photo

Animal: _____

Habitat: _____

Type of Food: _____



Animal: _____
Habitat: _____
Type of Food: _____



Animal: _____
Habitat: _____
Type of Food: _____



Animal: _____
Habitat: _____
Type of Food: _____



Animal: _____
Habitat: _____
Type of Food: _____



Animal: _____
Habitat: _____
Type of Food: _____



Animal: _____
Habitat: _____
Type of Food: _____



Animal: _____
Habitat: _____
Type of Food: _____

Identify the following tracks.



Sarah Neigum
NDGFD



Silvertip Productions

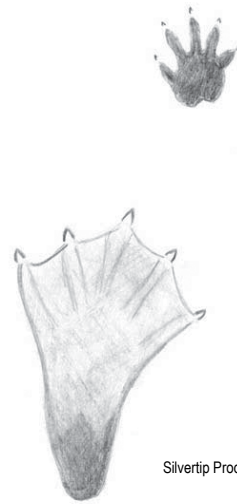

Silvertip Productions



Silvertip Productions



Silvertip Productions



Silvertip Productions



- Activist** A person who takes direct, often confrontational, action to support or oppose a cause.
- Additive Mortality**..... Harvests that exceed natural mortality and reduce a species' population.
- Aesthetic**..... Concerning the appreciation of beauty.
- AFWA**..... Association of Fish and Wildlife Agencies.
- Animal Rights**..... The belief that animals should have the same "rights" as humans.
- Apathetic**..... Indifference, lacking interest or concern.
- Asphyxiate** To stop the breathing of an animal.
- Badly Sewn**..... Where leg holes and cuts are poorly sewn or where bad damage has been caused by too much sewing.
- Badly Shot**..... A pelt peppered by a shotgun or large rifle. Bad bites may also be listed in this grade.
- Bag Limit** Number of animals legally allowed to be taken in a day or a season.
- Best Management Practices**..... The use of recommended equipment and techniques as determined by experts in an activity.
- Biological Carrying Capacity** .. The number of animals a given area of habitat is capable of supporting throughout the year.
- Bitten**..... Pelt has holes caused by bites. This is most common in muskrats and beaver during late winter or early spring when they're breeding and defending or establishing territories.
- Blue Pelt** An unprimed pelt. When dried, shows dark blue or black on the skin side.
- BMP**..... Short for Best Management Practice
- Body-Gripping Trap** A trap designed to close on an animal's body and quickly kill it.
- Burnt**..... Pelt is brittle and sometimes cracked, usually from drying too fast near a heater or in the sun or wind. Can also be caused by leaving too much fat on the pelt.
- Cable Device**..... A device designed to capture a furbearer by use of a multi-strand steel cable.
- Cable Restraint** A cable device designed to hold an animal alive.
- Cable Stake** An earth anchor attached to a cable and driven into the ground used to secure a trap without using a stake.
- Cache** Food stored for use at a later time, for example, the food pile of branches made by a beaver, or a mouse buried by a fox.
- Cage Trap** A trap designed of wire mesh to enclose an animal and hold it alive.
- Carnivore** An animal that eats other animals.
- Carrying Capacity** A term referring to the number of animals that a given area of habitat is capable of supporting.
- Cased Pelt** A pelt skinned by cutting along the hind legs and pulled down over the body.
- Castor** An odorous, glandular substance obtained from beaver, used in lures and perfume.
- Catchpole** A slip-noose on a rigid handle used to hold an animal while releasing it.
- Chop Voice**..... Describes a hound with a short bark.
- Clear Pelt**..... In mink and otter, this term indicates an even change in fur color from underfur to guard hairs.
- Clipped** Patches of guard hair that have been chewed off by rodents.
- Cold-trailing**..... Ability of a hound to follow an old track with less scent than a fresh track.
- Colony Trap** A wire mesh kill-type trap used in runways underwater for mink and muskrats, capable of catching multiple animals.
- Compensatory Mortality**..... Harvests that do not add to or exceed mortality from natural causes.
- Conservation**..... The careful guarding of an asset. Conservation allows for the use of resources within limits.



- Cotton Mink** A mink pelt with white underfur.
- Course** Guard hairs are dull, lifeless and hard to the touch. Usually seen in late-caught furs.
- Crepuscular** Active at morning and/or evening twilight.
- Cultural** The total product of human creativity and intellect.
- Cultural Carrying Capacity** The number of animals that humans will accept in a given area. When people want to reduce animal populations that are otherwise within the biological carrying capacity for the area, biologists may need to reduce the population until people find it acceptable.
- Deadfall** A primitive device designed to kill an animal with a falling log or rock, commonly used before the manufacture of modern traps. Deadfalls are not legal in most areas.
- Delayed Implantation** In animal reproduction, this refers to the fertilized egg not implanting and beginning development for some time after mating occurs.
- Dispatch** To kill an animal without delay in a humane manner.
- Dispersal** The one-way movement of animals from their place of birth or home range, often coinciding with sexual maturity.
- Diurnal** Active during the day.
- Drowning Device** Properly called a submersion device. A trap chain is attached to a slide lock on a cable leading to deep water. A trapped animal can go into deeper water, but not return, leading to death.
- Echinococcus** A tapeworm parasite that can form cysts in humans and other wild animals.
- Ecological Succession** The progressive changing of types of plants in a landscape that occurs over time.
- Ecology** The science of relationships between organisms and their environment.
- Ecosystem** A community of plants, animals and microorganisms linked by energy and nutrient flows that interact with each other and with the physical environment.
- Efficiency** Skillfulness in avoiding wasted time and energy.
- Endangered Species** A species whose population is so small that it is in danger of extinction.
- Ermine** White color phase of the weasel as seen during winter.
- Ethics** A person's personal code of behavior, moral values, and principles.
- Excise Tax** A tax that is measured by the amount of business done.
- Extinction** No longer in existence. Total extermination.
- Extirpation** Elimination of a species within a range or boundary where it once existed.
- Flat** Guard hairs lay flat because the underfur isn't fully developed. Usually seen in early-caught furs.
- Fleshing** Removing fat and meat from a pelt.
- Fleshing Beam** Wooden or fiberglass form to hold and support a pelt while removing the fat and meat left after skinning.
- Foot Snare** A capture device designed to catch long-legged animals by locking its foot in a wire noose.
- Foothold Trap** A capture device designed to hold an animal by the foot. May be used to hold animals alive, or to kill them in submersion sets.
- Fossorial** An animal adapted for burrowing or digging.
- Frostbite** A serious health hazard involving the freezing of the skin or other body tissues.
- Fur Dressing** The tanning process.
- Fur Stretcher** A frame that holds a pelt in a standard shape while drying.
- Gait** The way that an animal moves its feet when it walks or runs.



- Gambrel** A frame or device used for hanging an animal by the hind legs for skinning.
- Gestation Period**..... Length of pregnancy.
- Grapple** A hook-like device attached to the trap chain which allows an animal to move from the trap site and become entangled.
- Green Pelt** A pelt that has not been stretched or dried.
- Guard Hairs** Long, glossy hairs that overlap and protect the soft, dense underfur.
- Guarded Trap**..... A foothold trap with a spring device that pins the animal and prevents it from twisting or pulling free.
- Habitat**..... A place that provides all the food, water, shelter and space an animal needs to live.
- Hair Follicle**..... The part of the skin that produces and holds the hair or fur.
- Herbivore**..... An animal that normally feeds on plants.
- Heritage** Practices handed down from the past by tradition.
- Hibernation** A state of inactivity that some animals enter in winter.
- Home Range**..... The area where an animal lives or travels day to day.
- Hudson's Bay Company**..... An early Canadian fur trading company is still active today as North American Fur Auctions.
- Hypothermia** A serious health risk that involves the loss of body heat.
- Lap Link**..... A metal ring attaching a trap to a stake. It allows the chain to rotate around the stake.
- Live-Restraining**..... A trap or device designed to hold an animal without killing it.
- Loose**..... Guard hairs are coming out, usually because the roots have been cut by over-fleshing. Sometimes seen in early-caught furs.
- Lyme Disease**..... A disease transmitted to humans by certain ticks.
- Nocturnal**..... Active at night.
- Nonpowered Cable Device**..... A capture device using multi-strand steel cable that closes when an animal passes through it without the aid of a spring or other powering device.
- Omnivore**..... An animal that eats both plants and animals.
- Open Pelt** A pelt skinned by cutting down the midline of the belly.
- Open Trailer**..... A hound that barks a lot while on track.
- Open-Voiced Bawl Mouth**..... Describes a hound that has a tendency to bark a lot.
- Opportunist** An animal that takes advantage of the most abundant or easily obtainable source of food.
- Overstretch** Stretching the pelt beyond normal size; thins the leather and gives a flat and weak appearance.
- Pan Cover** A piece of canvas, cloth, wax paper or other material used to cover a trap pan and prevent soil from getting underneath it.
- Pan Tension** The amount of force, measured in weight, that it takes to trip a trap pan.
- Pan Throw** The distance a trap pan must move before the trap is sprung.
- Parasite** A plant or animal that lives in or on a host, and derives nourishment from the host.
- Pelage** An animal's hair or fur.
- Pelt** An animal's skin and fur after it has been taken off the body.
- Photoperiod**..... The length or amount of daylight; it regulates biological changes in animals, for example, primeness of fur, breeding and hibernation.
- Poaching**..... Killing protected animals, or killing animals out of season or by unlawful means.



- Powered Cable Device**..... A capture device using multi-strand steel cable designed to catch and hold an animal with the aid of a powering device, such as springs.
- Preservation**..... Protecting something from loss or danger. Implies very little or no use of a wildlife resource.
- Prime Pelt**..... A desirable pelt with the winter fur grown in and mature hair follicles.
- Privilege** A special advantage or benefit not enjoyed by all.
- Protected Species**..... A species that may not be harmed or killed. Eagles, hawks and owls, for example, are protected species.
- Rabies**..... A serious animal disease that can be transmitted to humans, primarily by saliva from infected animals.
- Rare Species** A species that is very uncommon, even in its favored habitat.
- Raw Fur** A pelt that has not been tanned or salted.
- Responsibility** An obligation. The social force that binds you to your obligations and the courses of action demanded by that force.
- Right**..... An abstract idea of something that is due to a person by law, tradition, or nature.
- Rubbed Fur**..... Parts of a pelt where fur is damaged by an animal rubbing it on dens, roots or other objects.
- S-Hook** A device for attaching a trap chain to a stake, allowing the chain to rotate around the stake.
- Safety Gripper**..... A device used to hold a body-gripping trap in the set position while it is being handled by a trapper.
- Samson Pelt** A pelt lacking or nearly lacking guard hairs.
- Scat** Animal droppings or feces.
- Scavenger**..... An animal that feeds on dead animals instead of killing its own food.
- Scored** Mark left by a bullet or knife that cut part-way through the leather.
- Selectivity** Tendency for a capture device set to target a single species.
- Set (Trap Set)** The area where a capture device has been set along with other preparations made by the trapper.
- Shedder**..... Fur “sheds” easily from the pelt when raked with the fingers. Can be seen with late caught furs or caused by putting the pelt on a stretcher while the fur is still wet.
- Silent Trailer** A hound that barks very little while on track.
- Singed Fur** Metallic sheen on otter fur caused by curled tips of the guard hairs. This damage can occur from excessive dry heat, direct sunlight, stroking dry fur, contact with freezing metal, or by the otter itself during the late season.
- Slow Trailer**..... A hound that trails track to track instead of skipping across several tracks.
- Snare** A restraining device made from a cable and a locking mechanism, and a term used to describe old style devices made from other materials.
- Snared** A term used to describe fur that is rubbed off the pelt by snare cable.
- Social Carrying Capacity**..... The number of animals people will tolerate in a given area.
- Species**..... A group of like animals capable of interbreeding.
- Springy** Underfur is falling out or kinked or woolly in appearance. Usually seen in late caught furs.
- Submarine Trap**..... A “cage” type trap that is set underwater in a channel or in front of a den for muskrats, mink, or otters.
- Submersion Set**..... A capture device attached to a slide cable, or one where a tangle stake is used, designed to cause a furbearer to asphyxiate underwater. Sometimes called a “drowning” set.
- Subsistence** A means of surviving.
- Sustainable**..... Capable of being maintained indefinitely.
- Swivel** A device used at the ends and/or middle of a trap chain to reduce injury to a trapped animal.



- Tainted** Part of the pelt is spoiled. Usually caused by waiting too long before skinning an animal or failing to remove enough of the tissue and fat during the fleshing process.
- Tanning**..... Treating a hide to make it into leather.
- Territory** The part of an animal's home range that it will defend from other animals of the same species.
- Threatened Species**..... A species that is rare and declining, and likely to become an endangered species in the foreseeable future through most or all of its range.
- Trap Bed** A hole or depression dug in the ground where a trap is placed.
- Trap Hook**..... A pole with a hook at one end to help find and recover traps from water. Often used as a wading stick.
- Trap Line**..... All of the traps and sets in use at a given time by a single trapper.
- Tularemia**..... A bacterial disease of rabbits and rodents that can be transmitted to humans through cuts or scratches while skinning infected animals.
- Underfur**..... Soft, dense fibers lying below the guard hairs. Provides primary insulation for the animal.
- Understretch** Stretching smaller than normal size causing wrinkles and sloppy appearance.
- Utilitarian** Someone who believes that a value of a thing or animal depends on its usefulness.
- Verendrye** The primary founder of the northern North Dakota fur trade.
- Voyageurs** French Canadians employed by the early fur companies to transport furs and trade goods through the wilderness, primarily by canoe.
- Welfare**..... Something that aids or promotes wellbeing.

Chapter 22

References



Wildlife Management and Ecology

- Conservation and the Use of Wildlife Resources, edited by M. Bolton, Chapman & Hall, Florence, KY, 1997. ISBN:0-41271-350-0
- Wild Mammals of North America: Biology, Management and Economics, edited by J.A. Chapman and G.A. Feldhamer. The Johns Hopkins University Press, Baltimore, MD, 1982. ISBN:0-8018-2353-6
- Wild Furbearer Management and Conservation in North America, edited by M. Novak, J.A. Baker, M.E. Obbard and B. Malloch. Ontario Trappers Assoc., Toronto, 1987. ISBN:0-7743-9365-3
- Practical Wildlife Management by G.V. Burger. Winchester Press, New York, NY. 1976. ISBN: 0-87691-099-1
- Wildlife-Habitat Relationships: Concepts and Applications, by M.L. Morrison, B.G. Marcot and W. Mannan, University of Wisconsin Press, Madison, 1998.
- Urban Wildlife Habitats: A Landscape Perspective, by L.W. Adams, University of Minnesota Press, Minneapolis, 1994. ISBN:80-8166-2212-4
- Techniques for Wildlife Management of Wetlands, edited by N.F. Payne, McGraw-Hill, Inc., New York, 1992. ISBN:0-07-048956-4
- Techniques for Wildlife Management of Uplands, edited by N.F. Payne and F.C. Bryant, McGraw-Hill, Inc., New York, 1994. ISBN:0-07-048966-1
- A Sand County Almanac, by A. Leopold, Oxford University Press, New York, 1991. ISBN:0-345-25336-1
- Trapping and Conservation Manual, 5th Edition, by Alberta Forestry, Lands, and Wildlife – Fish and Wildlife Division, Edmonton, Alberta, Canada 1987
- Ohio Snaring Guide, by Ohio Department of Natural Resources—Division of Wildlife and Ohio State Trappers Association, 1999.
- Dynamite Snares and Snaring, by Tom Krause, Riverton, WY.
- A Guide to Cable Restraints, by Wisconsin Department of Natural Resources, 2001.

Species Accounts

- Beavers: Water, Wildlife and History, by E.L. Hilfiker, Windswept Press, Interlaken, NY, 1982. ISBN:1-55787-068-3
- The Biology of the Striped Skunk, by B.J. Verts, University of Illinois Press, Urbana, 1967.
- Eastern Coyote: The Story of Its Success, by G. Parker, Nimbus Publishing, Halifax, Nova Scotia, 1995. ISBN:1-55109-111-9
- Muskrats and Marsh Management by P.L. Errington, Stackpole Co., Harrisburg, PA and The Wildlife Management Institute, Washington, D.C., 1961.
- Ecology and Management of the Eastern Coyote, by A.H. Boer, Wildlife Research Unit, University of New Brunswick, Fredericton, NB, 1992. ISBN:0-920114-17-2
- Red Fox—The Catlike Canine, by J.D. Henry, Smithsonian Institution Press, Washington, D.C. 1986. ISBN: 1-56098-635-2

Wildlife Diseases

- Infectious Diseases of Wild Mammals, Third Edition edited by E.S. Williams and I.K. Barker, The Iowa State University Press, Ames, 2001.
- Parasitic Diseases of Wild Mammals, edited by J.W. Davis and R.C. Anderson, The Iowa State University Press, Ames, 1971. ISBN:0-8138-1240-1

Books

- Hunting Dogs, Second Edition by F.P. Rice and J.I. Dahl, Outdoor Life-Funk and Wagnalls, New York, Book Division, Times Mirror Magazine Inc., 1978.



Fur Trade Magazines

Trapper and Predator Caller
www.trapperpredatorcaller.com

Fur – Fish – Game
www.furfishgame.com

Trappers Post
www.trapperspost.com

American Trapper
www.nationaltrappers.com

Trappers World
www.trappersworld.com

Supplies

Many suppliers advertise in the fur trade magazines.

Web Resources

U.S. Fish and Wildlife Service
www.fws.gov

National Trappers Association
www.nationaltrappers.com

North Dakota Fur Hunters and Trappers Association
www.ndfhfa.com

Fur Takers of America
www.furtakersofamerica.com

North Dakota Fur Takers
www.northdakotafurtakers.com

Fur Information Council of America
www.fur.org

Fur Institute of Canada
www.fur.ca

International Fur Trade Federation
www.iff.com

U.S. Sportsmen's Alliance
www.wlfa.org

The Wildlife Society



www.wildlife.org

Association of Fish & Wildlife Agencies

www.furbearermgmt.org (includes information and updates on Best Management Practices)

Furbearer Resources Technical Workgroup

www.furbearermgmt.org/

Searchable Field Guides for 5,500 Plants and Animals:

www.enature.com

Addresses for the following companies are provided for the convenience of students seeking trapping supplies or related services and does not imply endorsement or preference by the North Dakota Game and Fish Department or the North Dakota Cooperative Fur Harvester Education Program:

Groenewold Fur & Wool Co.

www.gfwco.com

North American Fur Auctions

www.nafa.ca

Fur Harvesters Auction, Inc.

www.furharvesters.com

Trapper and Predator Caller Magazine

www.trapperpredatorcaller.com

Egg Trap Company

www.theeggtrapcompany.com

Minnesota Trapline Products

www.minntrapprod.com

Northwest Trappers Supply

www.nwtrappers.com

Schmitt Enterprises

www.schmittent.com

Sterling Fur Company

11268 Frick Road

Sterling, Ohio 44276

The NDGFD receives Federal financial assistance from the US Fish and Wildlife Service. In accordance with Title VI of the Civil Rights Act of 1964, Section 504 of the Rehabilitation Act of 1973, Title II of the Americans with Disabilities Act of 1990, the Age Discrimination Act of 1975, and Title IX of the Education Amendments of 1972, the NDGFD joins the US Department of the Interior and its Bureaus in prohibiting discrimination on the basis of race, color, national origin, age, disability, sex (in education programs or activities) and also religion for the NDGFD. If you believe you have been discriminated against in any program, activity, or facility as described above, or you desire further information, please write to: ND Game and Fish Department, Attn: Chief Administrative Services, 100 N. Bismarck Expressway, Bismarck, ND 58501-5095 or to: U.S. Fish and Wildlife Service, Attn: Civil Rights Coordinator, 4401 N. Fairfax Drive, Mail Stop: MBSP-4020, Arlington, Virginia 22203. The TTY/TTD (Relay ND) number for the hearing or speech impaired is 1-800-366-6888.

Appendix A – Trap Selectivity Matrix



Trap Selectivity Matrix						
Selectivity Methods	Trap Types					
	Jaw Type Foothold	Foot Encapsulating	Stoploss	Cage	Body Gripping	Cable Restraint
1 Set location	Yes	Yes	Yes	Yes	Yes	Yes
2 Sized to target furbearer	Yes	Yes	Yes	Yes	Yes	Yes
3 Strength	Yes	n/a	Yes	n/a	Yes	Yes
4 Pan tension	Yes	n/a	n/a	n/a	n/a	n/a
5 Treadle tension	n/a	n/a	n/a	Yes	n/a	n/a
6 Trigger design	n/a	n/a	n/a	n/a	Yes	n/a
7 Trigger tension	n/a	n/a	n/a	n/a	Yes	n/a
8 Capture device design	n/a	Yes	n/a	Yes	n/a	n/a
9 Type or design of set	Yes	Yes	Yes	n/a	Yes	Yes
10 Use of lure or bait	Yes	Yes	n/a	Yes	Yes	n/a
11 Loop size	n/a	n/a	n/a	n/a	n/a	Yes
12 Loop height from ground	n/a	n/a	n/a	n/a	n/a	Yes
13 Sliding lock or mechanical lock	n/a	n/a	n/a	n/a	n/a	Yes
14 Break-a-way system	n/a	n/a	n/a	n/a	n/a	Yes

n/a – not applicable to this type of trap

Appendix B – Authentic Assessments



TRAP TEST AUTHENTIC ASSESSMENT				
Name:			Date:	
Instructor Name:				
Criteria	Failed	Passed with Assistance	Passed	Notes
IDs traps as kill-type or live-restraining devices: Show minimum of footholds, bodygripping, cable restraints, and cage trap.				
Trap ID – Style, Size: Show long-spring, coil-spring, bodygripping, cable restraints, cage, enclosed footholds				
IDs legal traps for state				
Matches traps with species:				
Safely sets legal traps				
Describes trap preparation: Minimum of foothold and bodygripping trap preparation				
Describes foothold trap tuning				
Passed – Y/N				

FURBEARER IDENTIFICATION AUTHENTIC ASSESSMENT				
Name:			Date:	
Instructor Name:				
Criteria	Failed	Passed with Assistance	Passed	Notes
IDs furbearers from pelt collection.				
Describes habitat				
Track identification				
Describes food habits				
Trap/hunt legal status				
Passed – Y/N				



LAWS AND REGULATIONS AUTHENTIC ASSESSMENT				
Name:			Date:	
Instructor Name:				
Criteria	Failed	Passed with Assistance	Passed	Notes
States where regulation brochures can be found				
Correctly states name of agency that regulates trapping				
Demonstrates use of regulations to show legal species to trap, seasons, legal traps				
Describes requirements regarding permission to trap				
Describes penalties for violating trapping regulations				
Describes training and licensing requirements for trapping				
Describes procedures for reporting trapping violations				
Passed – Y/N				

MAKING SETS AUTHENTIC ASSESSMENT				
Name:			Date:	
Instructor Name:				
Criteria	Failed	Passed with Assistance	Passed	Notes
Selecting location				
Select proper trap				
Staking/anchoring				
Digging the bed				
Bedding the trap				
Use of lure, bait, urine				
Selectivity				
Animal welfare				
Safety considerations				
Regulation compliance				
Passed – Y/N				



TRAPPING KNOWLEDGE AUTHENTIC ASSESSMENT				
Name:			Date:	
Instructor Name:				
Criteria	Failed	Passed with Assistance	Passed	Notes
Describe wildlife habitat used by furbearers				
Explain "carrying capacity"				
Describe how wildlife management is funded in North America				
Participation in class discussions on responsibility				
Describes or demonstrates fur handling procedures				
Describes how to sell furs				
Demonstrates safe and responsible attitudes about his/her role as a trapper				
Passed – Y/N				

CABLE DEVICES AUTHENTIC ASSESSMENT				
Name:			Date:	
Instructor Name:				
Criteria	Failed	Passed with Assistance	Passed	Notes
Identifies components of device and purpose				
Identifies or describes suitable locations for lethal and non-lethal sets				
Uses appropriate support system				
Uses appropriate anchoring system				
Uses appropriate loop size and loop height for target species				
Understands regulations related to cable devices				
Demonstrates a safe and responsible attitude about using cable devices				
Passed – Y/N				



FURBEARER HARVEST SURVEY
 NORTH DAKOTA GAME AND FISH DEPARTMENT
 WILDLIFE DIVISION
 SFN 6463 (3-2017)



PLEASE USE DARK INK

Shade Ovals Like This -- ● Not Like This -- ○

You have been randomly selected to help gather information on harvests of furbearers in North Dakota. Completion of this survey is voluntary, but is an important contribution to guiding furbearer management decisions in North Dakota. Please answer each of the questions as completely and as accurately as you can. Give us your best estimate if you can't remember precisely. Please include information about your furbearer activities for the preceding twelve months.

Did you purchase a North Dakota furbearer stamp or sportsman's license for the 2016-2017 season?

Yes No-if no, please STOP here and return this questionnaire.

	HUNTING			TRAPPING			SNARING			County you spent most time hunting/trapping/snaring?*
	Did you hunt?	For how many days?	Number Harvested	Did you trap?	For how many days?	Number Trapped	Did you snare?	For how many days?	Number Snared	
Fox	<input type="radio"/> Yes <input type="radio"/> No	<input type="text"/>	<input type="text"/>	<input type="radio"/> Yes <input type="radio"/> No	<input type="text"/>	<input type="text"/>	<input type="radio"/> Yes <input type="radio"/> No	<input type="text"/>	<input type="text"/>	<input type="text"/>
Coyote	<input type="radio"/> Yes <input type="radio"/> No	<input type="text"/>	<input type="text"/>	<input type="radio"/> Yes <input type="radio"/> No	<input type="text"/>	<input type="text"/>	<input type="radio"/> Yes <input type="radio"/> No	<input type="text"/>	<input type="text"/>	<input type="text"/>
Raccoon	<input type="radio"/> Yes <input type="radio"/> No	<input type="text"/>	<input type="text"/>	<input type="radio"/> Yes <input type="radio"/> No	<input type="text"/>	<input type="text"/>	<input type="radio"/> Yes <input type="radio"/> No	<input type="text"/>	<input type="text"/>	<input type="text"/>
Badger	<input type="radio"/> Yes <input type="radio"/> No	<input type="text"/>	<input type="text"/>	<input type="radio"/> Yes <input type="radio"/> No	<input type="text"/>	<input type="text"/>	<input type="radio"/> Yes <input type="radio"/> No	<input type="text"/>	<input type="text"/>	<input type="text"/>
Skunks	<input type="radio"/> Yes <input type="radio"/> No	<input type="text"/>	<input type="text"/>	<input type="radio"/> Yes <input type="radio"/> No	<input type="text"/>	<input type="text"/>	<input type="radio"/> Yes <input type="radio"/> No	<input type="text"/>	<input type="text"/>	<input type="text"/>
Beaver	<input type="radio"/> Yes <input type="radio"/> No	<input type="text"/>	<input type="text"/>	<input type="radio"/> Yes <input type="radio"/> No	<input type="text"/>	<input type="text"/>	<input type="radio"/> Yes <input type="radio"/> No	<input type="text"/>	<input type="text"/>	<input type="text"/>
Mink	<input type="radio"/> Yes <input type="radio"/> No	<input type="text"/>	<input type="text"/>	<input type="radio"/> Yes <input type="radio"/> No	<input type="text"/>	<input type="text"/>	<input type="radio"/> Yes <input type="radio"/> No	<input type="text"/>	<input type="text"/>	<input type="text"/>
Muskrat	<input type="radio"/> Yes <input type="radio"/> No	<input type="text"/>	<input type="text"/>	<input type="radio"/> Yes <input type="radio"/> No	<input type="text"/>	<input type="text"/>	<input type="radio"/> Yes <input type="radio"/> No	<input type="text"/>	<input type="text"/>	<input type="text"/>
Mountain Lion	<input type="radio"/> Yes <input type="radio"/> No	<input type="text"/>	<input type="text"/>	<input type="radio"/> Yes <input type="radio"/> No	<input type="text"/>	<input type="text"/>	<input type="radio"/> Yes <input type="radio"/> No	<input type="text"/>	<input type="text"/>	<input type="text"/>

* Refer to map on back for county code.

Appendix C – North Dakota Game and Fish Department Furbearer Survey

